



**Government of India
Ministry of Railways**

CHECKSHEETS

FOR

BOGIE HOPPER WAGON TYPE BOBSNM1 (DESIGN-C)

BROAD GAUGE (1676MM)

Sl. No.	Month/Year of issue	Revision/Amendment	Page No.	Reason for Amendment
1.	January- 2018	Nil	----	First issue

ISSUED BY

**RESEARCH DESIGNS & STANDARDS ORGANISATION
MINISTRY OF RAILWAYS
MANAK NAGAR, LUCKNOW-226011**

These check sheets do not detail all the dimensions or technical requirements of respective wagon assemblies / components.
These check sheets are issued only for General Guidance & assistance of inspecting officials. Notwithstanding the above, the inspecting officials are advised to refer to relevant drawings and / or relevant specifications to confirm conformity to the specified dimensions and technical details.

CONTENTS

Section A

Sr. No.	Description	Page No
1.	Contents	2
2.	Centre longitude	3
3.	Under frame	4
4.	Door Details	5
5.	Body Side	6
6.	Body End	7
7.	Final Assembly	8
8.	Final Wagon	9-11

These check sheets do not detail all the dimensions or technical requirements of respective wagon assemblies / components.
These check sheets are issued only for General Guidance & assistance of inspecting officials. Notwithstanding the above, the inspecting officials are advised to refer to relevant drawings and / or relevant specifications to confirm conformity to the specified dimensions and technical details.

Centre Longitude

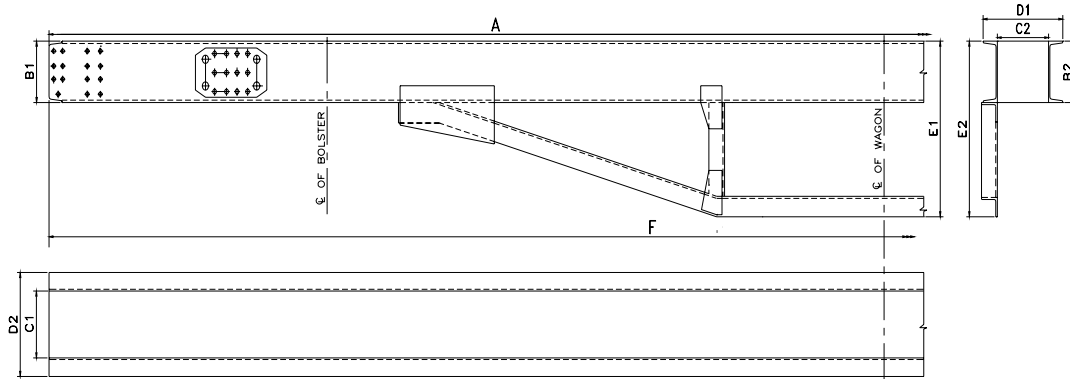

WD-94035-S-05

CENTRE SILL NO:			Date:			
SL. NO.	STAGE	Works Inspection	RDSO Inspection		Remarks	
2.0	Fabrication of Centre Longitude					
2.1	Fitment of all components					
2.2	Welding					
2.3	Dressing					
2.4	Riveting					
3.	Dimensions		As follows			
	LOCATION		Nominal Dimensions & Allowable Deviation	Actual Dimension		Remarks
				Works Inspection	RDSO Inspection	
i.	Length of centre Longitude	A	10648, +2,-2			
ii	Overall height of centre Longitude	B1/B2	300			
iii	Inside width of centre Longitude	C1,C2	327, +1.5, -0			
iv	Overall width of centre longitude bottom flange	D1	511, +1.5, -0			
		D2	511, +1.5, -0			
v	Height of sole bar assly.	E1	857			
		E2	857			
vi	Length of sole bar assly.	F	10648,+2, -2			
vii	Draft gear pocket	X	625.5, +0, -1.5			
		Y	327, +1.5, -0			

All dimensions are in mm

Works Inspector		RDSO Inspector	
Signature:		Signature:	
Name:		Name:	
Designation:		Designation:	
Date:		Date:	

These check sheets do not detail all the dimensions or technical requirements of respective wagon assemblies / components. These check sheets are issued only for General Guidance & assistance of inspecting officials. Notwithstanding the above, the inspecting officials are advised to refer to relevant drawings and / or relevant specifications to confirm conformity to the specified dimensions and technical details.

UNDERFRAME

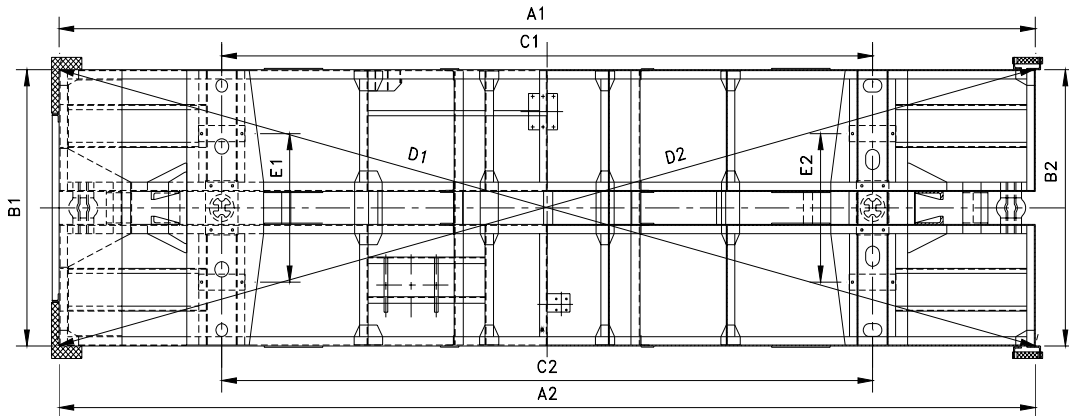

WD-17033-S-02

UNDERFRAME NO:		Date:				
SL. NO.	STAGE	Works Inspection		RDSO Inspection	REMARKS	
1.	Fitment of all components					
2.	Welding					
3.	Riveting					
3.	Dressing					
4.	Dimensions	As follows				
	LOCATION		Nominal Dimensions & Allowable Deviation	Actual Dimension		Remarks
				Works Inspection	RDSO Inspection	
i.	Length over head stock	A1 A2	10668, +7,-3			
ii.	Width over sole bar	B1 B2 B3	2743 ±3			
ii.	Distance between bolster bogie center	C1 C2	7112 ±2			
iv.	Diagonal difference overhead stocks	D1-D2	≤ 5			
vi.	Distance between side bearers Centre	E1 E2	1474±2			
vii.	Draft gear pocket	X	625.5, +0,-1.5			
		Y	327, +1.5, -0			
viii.	Camber		8±2mm			The camber value 8±2mm shall be achieved in final wagon

All dimensions are in mm

Works Inspector		RDSO Inspector	
Signature:		Signature:	
Name:		Name:	
Designation:		Designation:	
Date:		Date:	

These check sheets do not detail all the dimensions or technical requirements of respective wagon assemblies / components. These check sheets are issued only for General Guidance & assistance of inspecting officials. Notwithstanding the above, the inspecting officials are advised to refer to relevant drawings and / or relevant specifications to confirm conformity to the specified dimensions and technical details.

DOOR DETAILS

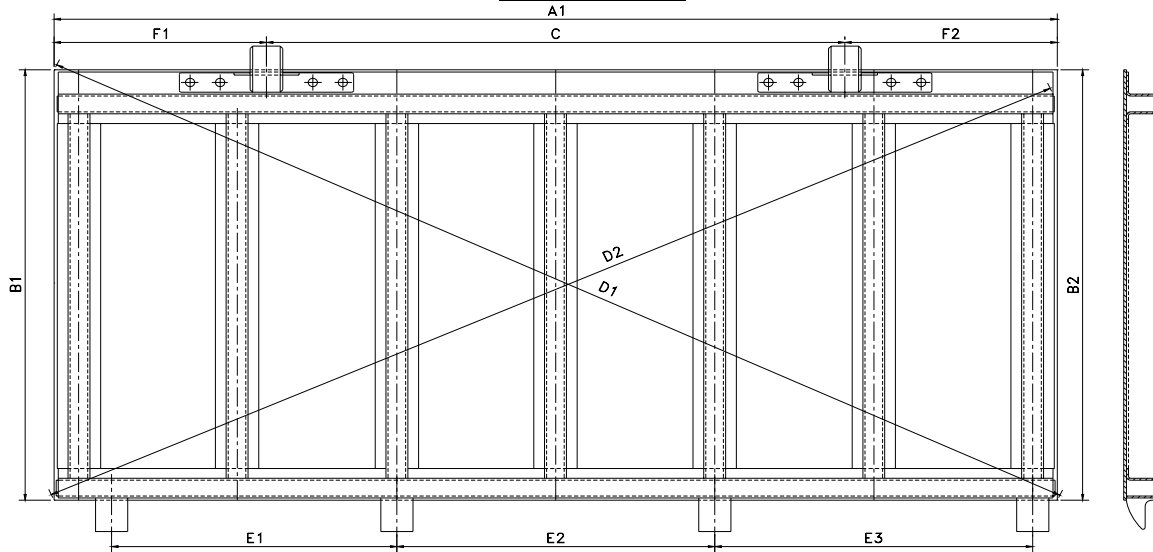

WD-94035-S-16

DOOR DETAILS NO:		Date:			
SL. NO.	STAGE	Works Inspection	RDSO Inspection	REMARKS	
1.	Fitment of all components				
2.	Welding				
3.	Riveting				
3.	Dressing				
4.	Dimensions	As follows			
	LOCATION	Nominal Dimensions & Allowable Deviation	Actual Dimension		Remarks
			Works Inspection	RDSO Inspection	
i.	Overall length	A1 A2	2338, +5,-0		
ii.	Overall height	B1 B2 B3	1114, +5,-0		
iii.	Distance between door hinges	C	1348, ±1.5		
iv.	Diagonal difference overhead stocks	D1/D2	≤ 3		
v.	Distance between door lip extension pieces	E1 E2 E3	665, ±1.5 741, ±1.5 741, ±1.5		
vi.	Distance between end to door hinge	F1 F2	495, ±1.5		

All dimensions are in mm

Works Inspector		RDSO Inspector	
Signature:		Signature:	
Name:		Name:	
Designation:		Designation:	
Date:		Date:	

These check sheets do not detail all the dimensions or technical requirements of respective wagon assemblies / components. These check sheets are issued only for General Guidance & assistance of inspecting officials. Notwithstanding the above, the inspecting officials are advised to refer to relevant drawings and / or relevant specifications to confirm conformity to the specified dimensions and technical details.

BODY SIDE

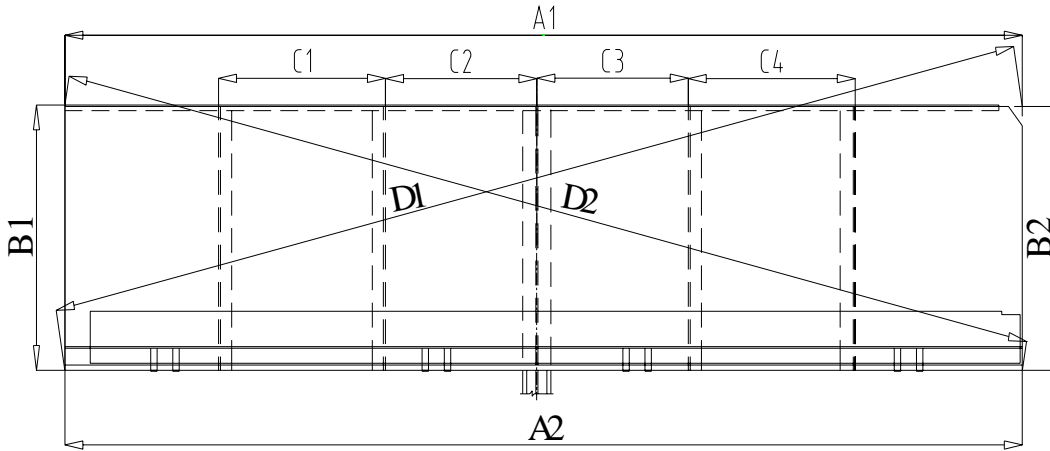

WD-12027-S-77

BODY SIDE NO:		Date:				
SL. NO.	STAGE	Works Inspection	RDSO Inspection	Remarks		
1.	Fitment of all components					
2.	Welding					
3.	Dressing					
4.	Dimensions	As follows				
	LOCATION		Nominal Dimensions & Allowable Deviation	Actual Dimension		Remarks
				Works Inspection	RDSO Inspection	
i.	Distance between side plate end to end	A1	4755±3			
		A2				
ii.	Side wall overall height	B1	952,±3			
		B2				
iii.	Distance between stanchions	C1	829, ±3			
		C2	752, ±3			
		C3	752, ±3			
		C4	829, ±3			
iv.	Diagonal difference	D1/D2	≤ 5			

All dimensions are in mm

Works Inspector		RDSO Inspector	
Signature:		Signature:	
Name:		Name:	
Designation:		Designation:	
Date:		Date:	

These check sheets do not detail all the dimensions or technical requirements of respective wagon assemblies / components. These check sheets are issued only for General Guidance & assistance of inspecting officials. Notwithstanding the above, the inspecting officials are advised to refer to relevant drawings and / or relevant specifications to confirm conformity to the specified dimensions and technical details.

BODY END

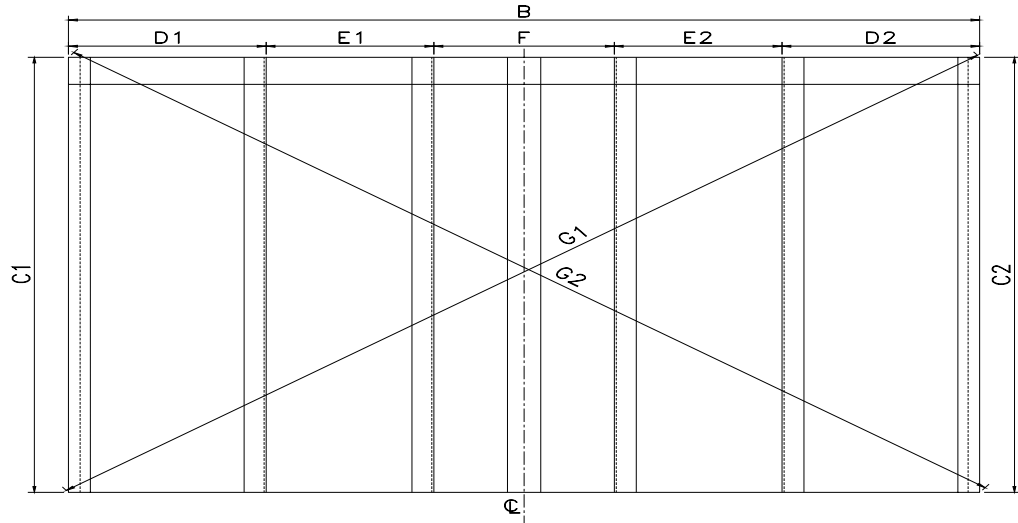

WD-12027-S-78

BODY END NO:			Date:			
SL. NO.	STAGE	Works Inspection	RDSO Inspection		Remarks	
1.	Fitment of all components					
2.	Welding					
3.	Dressing					
4.	Dimensions	As follows				
	LOCATION		Nominal Dimensions & Allowable Deviation	Actual Dimension		Remarks
				Works Inspection	RDSO Inspection	
i.	Width over corner stanchions	B	2743±3			
ii.	End wall overall height (from end plate bottom to top coping)	C1	2022 ±3			
		C2				
iii.	Distance between corner to outer stanchions	D1	595 ±1.5			
		D2				
iv.	Distance between outer to inner stanchion	E1	505 ±1.5			
		E2				
v.	Distance between inner to inner stanchion	F	543 ±1.5			
vi.	Diagonal difference over corner stanchions	G1/G2	≤ 5			

All dimensions are in mm

Works Inspector		RDSO Inspector	
Signature:		Signature:	
Name:		Name:	
Designation:		Designation:	
Date:		Date:	

These check sheets do not detail all the dimensions or technical requirements of respective wagon assemblies / components. These check sheets are issued only for General Guidance & assistance of inspecting officials. Notwithstanding the above, the inspecting officials are advised to refer to relevant drawings and / or relevant specifications to confirm conformity to the specified dimensions and technical details.

FINAL ASSEMBLY

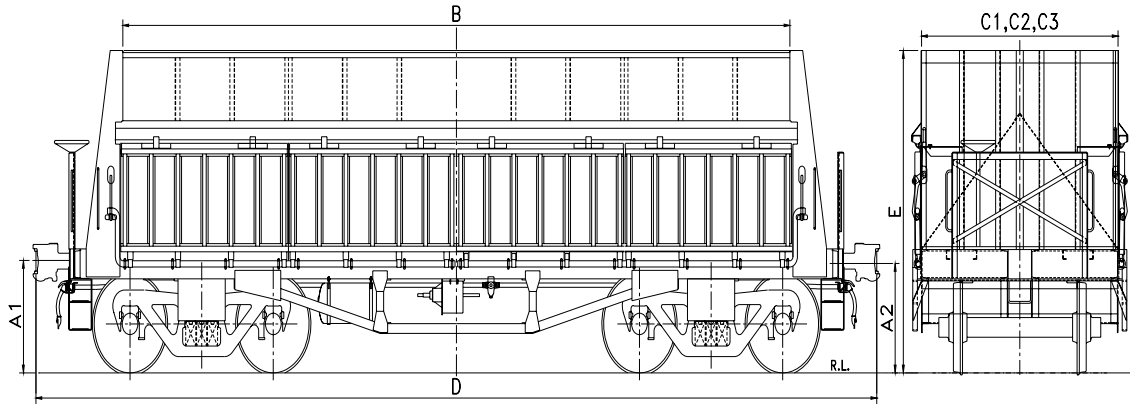

WD-94035-S-02

Wagon No.:		U/F No.:		Date:		
SL. NO.	STAGE	Works Inspection	RDSO Inspection	Remarks		
1.	Fitment of all components					
2.	Riveting					
3.	Welding					
4.	Operation of Doors					
5.	Operation of Couplers					
6.	Under gear Examination					
7.	Brake test i) Air brake ii) Hand brake					
8.	Shot Blasting (ExcpLever SAB)					
8.	Painting in second coat > 80 micron					
9.	Lettering					
10.	Dimensions	As follows				
	LOCATION		Nominal Dimensions & Allowable Deviation	Actual Dimension		Remarks
				Works Inspection	RDSO Inspection	
i.	Coupler height from R.L.	A1 A2	1105, +0, -5			
ii.	Length Inside	B	9296, +7, -3			
iii.	Width Inside	C1	2743, ± 3			
		C2				
		C3				
v.	Length over coupler face	D	11597, +7, -3			
vi.	Side bearer clearance		Nil			
ix.	Height Overall from R.L.	E	3301 ± 3			

All dimensions are in mm

Works Inspector		RDSO Inspector	
Signature:		Signature:	
Name:		Name:	
Designation:		Designation:	
Date:		Date:	

These check sheets do not detail all the dimensions or technical requirements of respective wagon assemblies / components. These check sheets are issued only for General Guidance & assistance of inspecting officials. Notwithstanding the above, the inspecting officials are advised to refer to relevant drawings and / or relevant specifications to confirm conformity to the specified dimensions and technical details.

**FINAL WAGON
RDSO**

Check Sheet for Bogie Hopper Wagon Type BOBSNM1(Design-C)

1.	a) Wagon No.		2.	Date of offer	
	b) Return Date:				
3.	Underframe No.		4.	Name of the Wagon Manufacturer:	
5.	Contract/P.O. placed by		6.	Contract/P.O. No. and date and D.P. (Up to)	
7.	Running Gear				
a)	Bearing Make			Serial Nos.	
b)	Wheel Make			Serial Nos.	
c)	Axle Make			Serial Nos.	
d)	Bogie Make & Sr. Nos.		e)	Air Brake Make	
f)	DV Make & Sr. no.		g)	SAB Make & Sr. No.	
h)	Date of air brake testing		i)	Date of SWTR unit calibration	
8.	Coupler Make & Sr. Nos.		9.	Draft Gear Make & Sr. Nos.	
10.	Tare Weight		11.	Shot blasting/manually cleaned	
12.	D.M. Issue date		13.	TXR fit memo issue date	

14. RAD availed _____

15. Defects Observed _____

16. Remarks _____

Works Inspector		RDSO Inspector	
Signature:		Signature:	
Name:		Name:	
Designation:		Designation:	
Date:		Date:	

These check sheets do not detail all the dimensions or technical requirements of respective wagon assemblies / components. These check sheets are issued only for General Guidance & assistance of inspecting officials. Notwithstanding the above, the inspecting officials are advised to refer to relevant drawings and / or relevant specifications to confirm conformity to the specified dimensions and technical details.

PROFORMA FOR SINGLE WAGON AIR BRAKE TEST

Wagon No.:		U/F No.:	Date:	
SL NO.	ATTRIBUTES	ACCEPTANCE LIMIT	WORKS INSPN.	RDSO INSPN.
1.	Check paint- for thickness & finish	Thickness >40 micron (DFT for primary paint) > 80 micron (DFT for finish paint). Total DFT after shall be minimum 120 micron. Paint surface to be free from blistering, brush marks & peeling.(As per G-72 Rev.3 or latest Revision)		
2.	Lettering & marking- for legibility, size, location & punch mark.	As per Drg. No.WD-94035-S-17		
3.	COUPLER			
3.1	Height from Rail Level	1105 , +0, - 5		
3.2	Operation of knuckle with operating handle	Full knuckle throw lock to lock		
3.3	Articulation of coupler body	Free movement		
4.	HAND BRAKE			
4.1	Apply hand brake (by one person only and strike all wheels with a Hammer)	There should not be ringing sound		
4.2	Release the hand brake and apply crow bar on one end of brake block to take up all slack	All brake blocks must be released. Gap between the brake block and wheel tread not to be less than 23.6 mm (5.9 x 4)		
5.	EMPTY LOAD BOX.			
5.1	Operate the mechanism from any end in empty and loaded positions	Empty tie rod & loaded tie rod must engage. In loaded position the empty tie rod pins must be loose. In empty position the loaded tie rod pins must be loose		
6.	AIR BRAKE & SLACK ADJUSTER			
6.1	Distance between the control rod head and adjuster barrel (A)	70 +2, - 0		
6.2	Dimension (e) i.e. the distance between the end of protection tube and fixed mark on the slack adjuster pull rod	575, ±10 mm		
6.3	Apply air brake and then release the same. Apply crow bar on one end of brake block to take up all slack	Gap should not be less than 23.6 mm (5.9 x4)		
6.4	Rotate the brake slack adjuster in clock-wise direction (looking from control rod end) to decrease the slack. Apply and release the air brake twice.	Gap between the brake block and wheel tread as measured should be 23.6, +1-0		
6.5	Now, rotate the barrel in anticlockwise direction. Apply and release the air brake once	Gap between the brake block and wheel tread as measured should be 23.6, +1,-0		
7.	AIR BRAKE EQUIPMENT			
	Full service application			
7.1	Pressure in B.P.	5 Kg/cm ²		
7.2	Pressure in A.R.	5 Kg/cm ²		
7.3	Leakage from the system	0.1 Kg/cm ² in 1 minute		

Works Inspector		RDSO Inspector	
Signature:		Signature:	
Name:		Name:	
Designation:		Designation:	
Date:		Date:	

These check sheets do not detail all the dimensions or technical requirements of respective wagon assemblies / components. These check sheets are issued only for General Guidance & assistance of inspecting officials. Notwithstanding the above, the inspecting officials are advised to refer to relevant drawings and / or relevant specifications to confirm conformity to the specified dimensions and technical details.

WD-CS-01-BOBSNM1 (Design-C)-2018

SL NO.	ATTRIBUTES	ACCEPTANCE LIMIT	WORKS INSPN.	RDSO INSPN.
7.4	B.C filling time in empty condition pressure rise from 0 to 3.6 Kg/cm ²)	Empty 18 to 30 seconds		
	B.C filling time in loaded condition pressure rise from 0 to 3.6 Kg/cm ²)	Loaded 18 to 30 seconds		
7.5	Maximum B.C. pressure in Kg/ cm ²	Empty 3.8 ±0.1 Kg/ cm ² Loaded 3.8 ± 0.1 Kg/ cm ²		
7.6	Decrease in B.P. pressure required for full service application	1.3 to 1.6 Kg/ cm ²		
8.	RELEASE AFTER FULL SERVICE APPLICATION			
8.1	Draining time- B.C pressure to fall from 3.8 ± 0.1 to 0.4 Kg/cm ²	Empty 45 to 60 seconds		
	Draining time- B.C pressure to fall from 3.8 ± 0.1 to 0.4 Kg/cm ²	Loaded 45 to 60 seconds		
9.	Piston stroke in mm	a) Empty 85 ±10 b) Loaded 130 ± 10		
10.	EMERGENCY APPLICATION			
10.1	B.C filling time a) EMPTY:-Pressure rise from 0 to 3.6 Kg/cm ²	Empty 18 to 30 seconds		
	b) LOADED:- Pressure rise from 0 to 3.6 Kg/cm ²	Loaded 18 to 30 seconds		
10.2	Maximum B.C pressure in Kg/cm ²	a) Empty 3.8 ± 0.1 Kg/cm ² b) Loaded 3.8 ± 0.1 Kg/cm ²		
10.3	Leakage from B.C.	0.1 Kg/cm ² in 5 minute		
11.	SENSITIVITY OF BRAKES			
11.1	Isolate brake pipe from main line check the response of brakes when brake pipe pressure is reduced at the most equal to 0.6 Kg/cm ² in 6 seconds	Brake should apply within 6 seconds		
12.	INSENSITIVITY OF BRAKES			
12.1	Isolate brake pipe from main line. Check the response of brakes when brake pipe pressure is reduced at least equal to 0.3 Kg/cm ² in 60 seconds	Brake should not apply		
13.	QUICK RELEASE AND ISOLATION			
13.1	After emergency brake application operate quick release valve	Brake cylinder and control reservoir should exhaust automatically.		
13.2	Bring isolating valve of distributor to off position.	Auxiliary reservoir should also exhaust.		
FOLLOWING POINTS TO BE CHECKED AT THE TIME OF PROTOTYPE WAGON ONLY.				
14	AR Charging time Pressure rise from 0 to 5.0 Kg/cm ²	175 ± 30 Sec. for C3W DV 60 to 120 Sec. for KEO DV		
15	CR Charging time Pressure rise from 0 to 4.8 Kg/cm ²	165 ± 20 Sec. for C3W DV 160 to 210 Sec. for KEO DV		

Works Inspector		RDSO Inspector	
Signature:		Signature:	
Name:		Name:	
Designation:		Designation:	
Date:		Date:	

These check sheets do not detail all the dimensions or technical requirements of respective wagon assemblies / components. These check sheets are issued only for General Guidance & assistance of inspecting officials. Notwithstanding the above, the inspecting officials are advised to refer to relevant drawings and / or relevant specifications to confirm conformity to the specified dimensions and technical details.