

INDIAN RAILWAYS



CHECKSHEETS

FOR

CRF SECTION OF BOGIE COVERED WAGON TYPE – BCNHL(DSIGN-D)

S.No.	Month & Year of issue	Revision / Amendment	Page No.	Reason for Amendment
1.	October - 2011	-	-	First issue

ISSUED BY

**RESEARCH DESIGNS AND STANDARDS ORGANISATION
MINISTRY OF RAILWAYS
LUCKNOW-226 011**

October - 2011

CONTENTS

Sr. No.	Description	Page No
1.	Sole Bar Stiffener	3
2.	Sole Bar	4
3.	End Centre Sill	5
4.	Centre Centre Sill	6
5 (a).	Stringer (End)	7
5 (b).	Stringer (Outer)	8
5 (c).	Stringer (Inner & Centre)	9
6 (a).	Side Stanchion	10
6 (b).	Side Stanchion (Inside)	11
6 (c).	Horizontal Stanchion Long (Inside)	12
6 (d).	Horizontal Stanchion Small (Inside)	13
7 (a).	End Coping Pressing	14
7 (b).	End Top Stanchion	15
7 (c).	End Stiffening Pressing Centre	16
8 (a).	Cross Member at Door (End)	17
8 (b).	Cross Member (Middle)	18
8 (c).	Cross Member (End)	19
9.	Longitude of Roof	20
10.	Corner Stanchion	21
11 (a).	Side Top Coping (End)	22
11 (b).	Side Top Coping (Middle)	23
12 (a).	End Stanchion (Bottom)	24
12 (b).	End Stanchion (Middle)	25
13.	Corner Roof Carline	26
14	Sampling plan	27-29

Note:

1.

These check sheets do not details all the dimensions or technical requirements of respective wagon assemblies/components.

These check sheets are issued only for general guidance & assistance of inspecting officials.

Notwithstanding the above, the inspecting officials are advised to refer to relevant drawings and/or relevant specifications to confirm conformity to the specified dimensions and technical details

2.

a. In check sheets wherever it is indicated that two dimensions are to be measured, it means measurement of that dimension at two end locations of the component.

b. In check sheets wherever it is indicated that three dimensions are to be measured, it means measurement of that dimension at two end locations of the component, and one at the center of the component.

Sole Bar Stiffener

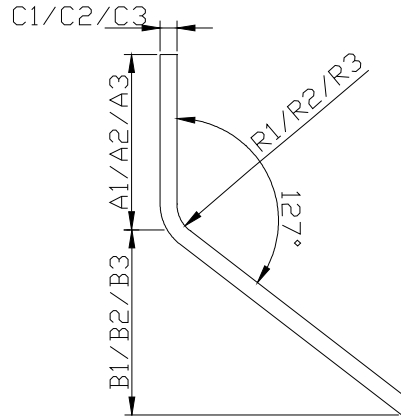

Ref: Drawing No. WD-10068- S-05, Item-1 & WD-10068-S-25, Item-1

Sole Bar Stiffener				Date:	
SL. NO.	STAGE	Works Inspection	Inspecting Authority	Remarks	
1	Dimensions	As follows			
	Location	Nominal Dimensions & Allowable Deviation	Actual Dimension		Remarks
			Works Inspection	Inspecting Authority	
i.	Flange	A1 A2 A3	73± 1.5		
ii.	Thickness	C1 C2 C3	7 ±0.35		
iii.	Height	B1 B2 B3	77 ± 1.5		
iv.	Length	Top Bottom	10034 +4 / -2		
v.	Radius	R1 R2 R3	12± 1.5		
vi.	Angle	-	127° ± 1°15'		
vii.	Waviness	-	2 max.		
viii.	Bow	-	1 in 600		
ix.	Camber	-	1 in 600		
x.	Twist	-	1 deg./metre		
xi.	Appearance	-	Free from Deep Marks, Cracks, & Other Defects		

All dimensions are in mm

Works Inspector		Inspecting Authority	
Signature:		Signature:	
Name:		Name:	
Designation:		Designation:	
Date:		Date:	

Sole Bar

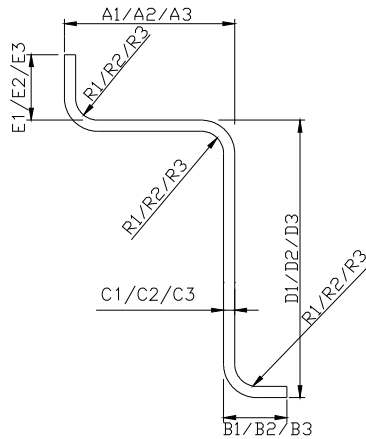

Ref: Drawing No. WD-10068- S-05, Item-1 & WD-10068-S-25, Item-2

Sole Bar			Date:		
SL. NO.	STAGE	Works Inspection	Inspecting Authority		Remarks
1	Dimensions	As follows			
	Location	Nominal Dimensions & Allowable Deviation	Actual Dimension		Remarks
			Works Inspection	Inspecting Authority	
i.	Top Flange	A1	107 ± 1.5		
		A2			
		A3			
ii.	Bottom Flange	B1	40 ± 1.25		
		B2			
		B3			
iii.	Thickness	C1	7 ± 0.35		
		C2			
		C3			
iv.	Height	D1	174 ± 1.5		
		D2			
		D3			
v.	Height of top flange	E1	41 ± 1.25		
		E2			
		E3			
vi.	Length	Top	10034 +4 / -2		
		Bottom			
vii.	Radius	R1	14 ± 1.5		
		R2			
		R3			
viii.	Angle	-	± 1°15'		
ix.	Waviness	-	2 max.		
x.	Bow	-	1 in 600		
xi.	Camber	-	1 in 600		
xii.	Twist	-	1 deg./metre		
xiii.	Appearance	-	Free from Deep Marks, Cracks, & Other Defects		

All dimensions are in mm

Works Inspector		Inspecting Authority	
Signature:		Signature:	
Name:		Name:	
Designation:		Designation:	
Date:		Date:	

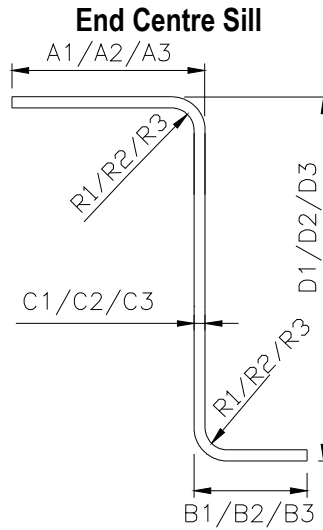

Ref: Drawing No. WD-10068- S-05, Item-2A & WD-10068-S-25, Item-3

End Centre Sill			Date:		
SL. NO.	STAGE	Works Inspection	Inspecting Authority		Remarks
1.	Dimensions	As follows			
	Location		Nominal Dimensions & Allowable Deviation	Actual Dimension	Remarks
				Works Inspection	Inspecting Authority
i.	Top Flange	A1 A2 A3	173.5 ± 1.75		
ii.	Bottom Flange	B1 B2 B3	101.5 ± 1.75		
iii.	Thickness	C1 C2 C3	10 ± 0.50		
iv.	Height	D1 D2 D3	327 + 1.5 / - 1.0		
v.	Length	Top Bottom	2707.5 +3 / -1		
vi.	Radius	R1 R2 R3	20± 1.5		
vii.	Angle	-	± 1°		
viii.	Waviness	-	2 max.		
ix.	Bow	-	1 in 600		
x.	Camber	-	1 in 600		
xi.	Twist	-	1 deg./metre		
xii.	Appearance	-	Free from Deep Marks, Cracks, & Other Defects		

. All dimensions are in mm

Works Inspector		Inspecting Authority	
Signature:		Signature:	
Name:		Name:	
Designation:		Designation:	
Date:		Date:	

Centre Centre Sill

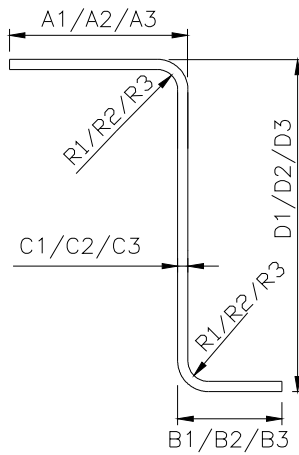

Ref: Drawing No. WD-10068- S-05, Item-2B & WD-10068-S-25, Item-4

End Centre Sill			Date:		
SL. NO.	STAGE	Works Inspection		Inspecting Authority	Remarks
1.	Dimensions	As follows			
	Location		Nominal Dimensions & Allowable Deviation	Actual Dimension	Remarks
				Works Inspection	Inspecting Authority
i.	Top Flange	A1	171.5 ± 1.75		
		A2			
		A3			
ii.	Bottom Flange	B1	75 ± 1.5		
		B2			
		B3			
iii.	Thickness	C1	8 ± 0.40		
		C2			
		C3			
iv.	Height	D1	270 + 1.5 / - 1.0		
		D2			
		D3			
v.	Length	Top	4839 +3 / -1		
		Bottom			
vi.	Radius	R1	16± 1.5		
		R2			
		R3			
vii.	Angle	-	± 1°15'		
viii.	Waviness	-	2 max.		
ix.	Bow	-	1 in 600		
x.	Camber	-	1 in 600		
xi.	Twist	-	1 deg./metre		
xii.	Appearance	-	Free from Deep Marks, Cracks, & Other Defects		

. All dimensions are in mm

Works Inspector		Inspecting Authority	
Signature:		Signature:	
Name:		Name:	
Designation:		Designation:	
Date:		Date:	

Stringer (End)

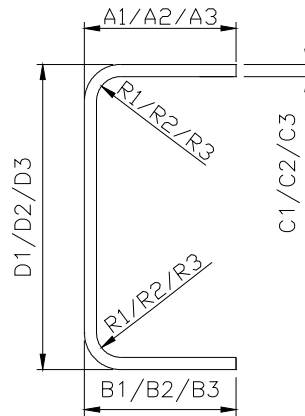

Ref: Drawing No. WD-10068- S-06, Item-1 & WD-10068-S-25, Item-5 (a)

Stringer (End)			Date :		
SL. NO.	STAGE	Works Inspection	Inspecting Authority		Remarks
1.	Dimensions	As follows			
	Location		Nominal Dimensions & Allowable Deviation	Actual Dimension	
				Works Inspection	Inspecting Authority
i.	Top Flange	A1 A2 A3	50 ± 1.25		
ii.	Bottom Flange	B1 B2 B3	50 ± 1.25		
iii.	Thickness	C1 C2 C3	4 ± 0.2		
iv.	Height	D1 D2 D3	100 ± 1.0		
v.	Length	Top Bottom	1240.5 ± 1.0		
vi.	Radius	R1 R2 R3	6 ± 1.5		
vii.	Angle	-	± 1°15'		
viii.	Waviness	-	2 max.		
ix.	Bow	-	1 in 600		
x.	Camber	-	1 in 600		
xi.	Twist	-	1 deg./metre		
xii.	Appearance	-	Free from Deep Marks, Cracks, & Other Defects		

All dimensions are in mm

Works Inspector		Inspecting Authority	
Signature:		Signature:	
Name:		Name:	
Designation:		Designation:	
Date:		Date:	

Stringer (Outer)

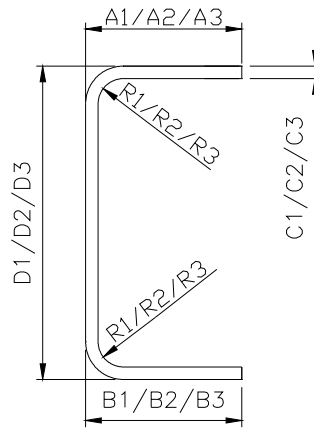

Ref: Drawing No. WD-10068- S-06, Item-2 & WD-10068-S-25, Item-5 (b)

Stringer (End)		Date :		
SL. NO.	STAGE	Works Inspection	Inspecting Authority	Remarks
1.	Dimensions	As follows		
	Location	Nominal Dimensions & Allowable Deviation	Actual Dimension	
			Works Inspection	Inspecting Authority
i.	Top Flange	A1 A2 A3	50 ± 1.25	
ii.	Bottom Flange	B1 B2 B3	50 ± 1.25	
iii.	Thickness	C1 C2 C3	4 ± 0.2	
iv.	Height	D1 D2 D3	100 ± 1.0	
v.	Length	Top Bottom	1237 ± 1.0	
vi.	Radius	R1 R2 R3	6 ± 1.5	
vii.	Angle	-	± 1°15'	
viii.	Waviness	-	2 max.	
ix.	Bow	-	1 in 600	
x.	Camber	-	1 in 600	
xi.	Twist	-	1 deg./metre	
xii.	Appearance	-	Free from Deep Marks, Cracks, & Other Defects	

All dimensions are in mm

Works Inspector		Inspecting Authority	
Signature:		Signature:	
Name:		Name:	
Designation:		Designation:	
Date:		Date:	

Stringer (Inner & Centre)

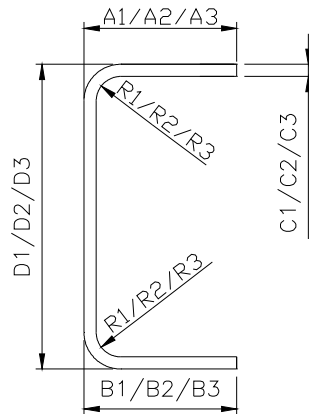

Ref: Drawing No. WD-10068- S-06, Item-3 & WD-10068-S-25, Item-5 (c)

Stringer (End)			Date :			
SL. NO.	STAGE	Works Inspection		Inspecting Authority	Remarks	
1.	Dimensions	As follows				
	Location		Nominal Dimensions & Allowable Deviation	Actual Dimension		Remarks
				Works Inspection	Inspecting Authority	
i.	Top Flange	A1 A2 A3	50 ± 1.25			
ii.	Bottom Flange	B1 B2 B3	50 ± 1.25			
iii.	Thickness	C1 C2 C3	4 ± 0.2			
iv.	Height	D1 D2 D3	100 ± 1.0			
v.	Length	Top Bottom	1425 ± 1.0			
vi.	Radius	R1 R2 R3	6 ± 1.5			
vii.	Angle	-	± 1°15'			
viii.	Waviness	-	2 max.			
ix.	Bow	-	1 in 600			
x.	Camber	-	1 in 600			
xi.	Twist	-	1 deg./metre			
xii.	Appearance	-	Free from Deep Marks, Cracks, & Other Defects			

All dimensions are in mm

Works Inspector		Inspecting Authority	
Signature:		Signature:	
Name:		Name:	
Designation:		Designation:	
Date:		Date:	

Side Stanchion

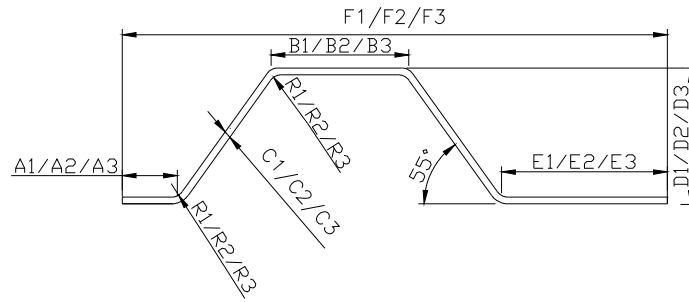

Ref: Drawing No. WD-10068- S-14, Item-02 & WD-10068-S-25, Item-6 (a)

Side Stanchion		Date:		
SL. NO.	STAGE	Works Inspection	Inspecting Authority	Remarks
1.	Dimensions	As follows		
	Location	Nominal Dimensions & Allowable Deviation	Actual Dimension	Remarks
			Works Inspection	Inspecting Authority
i.	Left Flange	A1 A2 A3 20 ± 1.25		
ii.	Right Flange	E1 E2 E3 60 ± 1.25		
iii.	Top width	B1 B2 B3 50 ± 1.00		
iv.	Bottom width	F1 F2 F3 198 ± 1.50		
v.	Thickness	C1 C2 C3 2.5 ± 0.20		
vi.	Height	D1 D2 D3 50 ± 1.00		
vii.	Length	Top Bottom 2059 +3.0 / -1.0		
viii.	Radius	R1 R2 R3 4 ± 1.5		
ix.	Angle	-	± 1°15'	
x.	Waviness	-	2 max.	
xi.	Bow	-	1 in 600	
xii.	Camber	-	1 in 600	
xiii.	Twist	-	1 deg./metre	
xiv.	Appearance	-	Free from Deep Marks, Cracks, & Other Defects	

All dimensions are in mm

Works Inspector		Inspecting Authority	
Signature:		Signature:	
Name:		Name:	
Designation:		Designation:	
Date:		Date:	

Side Stanchion (Inside)

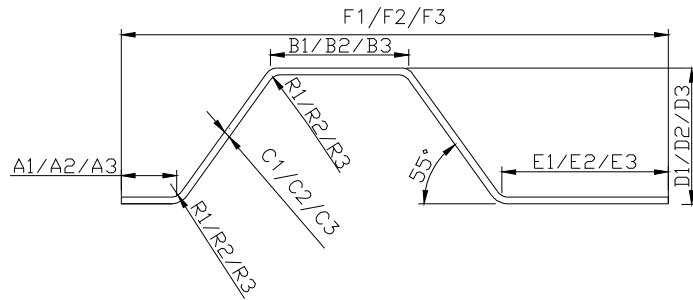

Ref: Drawing No. WD-10068- S-14, Item-02 & WD-10068-S-25, Item-6 (b)

Side Stanchion		Date:		
SL. NO.	STAGE	Works Inspection	Inspecting Authority	Remarks
1.	Dimensions	As follows		
	Location	Nominal Dimensions & Allowable Deviation	Actual Dimension	Remarks
			Works Inspection	Inspecting Authority
i.	Left Flange	A1 A2 A3 20 ± 1.25		
ii.	Right Flange	E1 E2 E3 60 ± 1.25		
iii.	Top width	B1 B2 B3 50 ± 1.00		
iv.	Bottom width	F1 F2 F3 198 ± 1.50		
v.	Thickness	C1 C2 C3 2.5 ± 0.20		
vi.	Height	D1 D2 D3 50 ± 1.00		
vii.	Length	Top Bottom 2045 +3.0 / -1.0		
viii.	Radius	R1 R2 R3 4 ± 1.5		
ix.	Angle	-	± 1°15'	
x.	Waviness	-	2 max.	
xi.	Bow	-	1 in 600	
xii.	Camber	-	1 in 600	
xiii.	Twist	-	1 deg./metre	
xiv.	Appearance	-	Free from Deep Marks, Cracks, & Other Defects	

All dimensions are in mm

Works Inspector		Inspecting Authority	
Signature:		Signature:	
Name:		Name:	
Designation:		Designation:	
Date:		Date:	

Horizontal Stanchion Long (Inside)

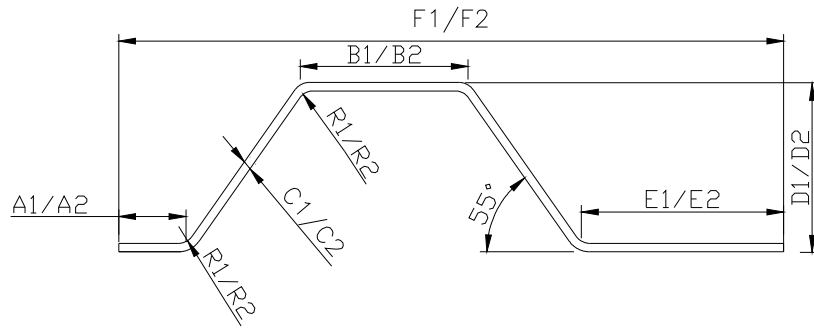

Ref: Drawing No. WD-10068- S-13, Item-20 & WD-10068-S-25, Item-6 (c)

Side Stanchion*			Date:			
SL. NO.	STAGE	Works Inspection		Inspecting Authority		Remarks
1.	Dimensions	As follows				
	Location		Nominal Dimensions & Allowable Deviation	Actual Dimension		Remarks
				Works Inspection	Inspecting Authority	
i.	Left Flange	A1 A2	20 ± 1.25			
ii.	Right Flange	E1 E2	60 ± 1.25			
iii.	Top width	B1 B2	50 ± 1.00			
iv.	Bottom width	F1 F2	198 ± 1.50			
v.	Thickness	C1 C2	2.5 ± 0.20			
vi.	Height	D1 D2	50 ± 1.00			
vii.	Length	Top Bottom	602 ± 1.00			
viii.	Radius	R1 R2	4 ± 1.5			
ix.	Angle	-	± 1°15'			
x.	Waviness	-	2 max.			
xi.	Bow	-	1 in 600			
xii.	Camber	-	1 in 600			
xiii.	Twist	-	1 deg./metre			
xiv.	Appearance		Free from Deep Marks, Cracks, & Other Defects			

All dimensions are in mm

Works Inspector		Inspecting Authority	
Signature:		Signature:	
Name:		Name:	
Designation:		Designation:	
Date:		Date:	

Horizontal Stanchion Small (Inside)

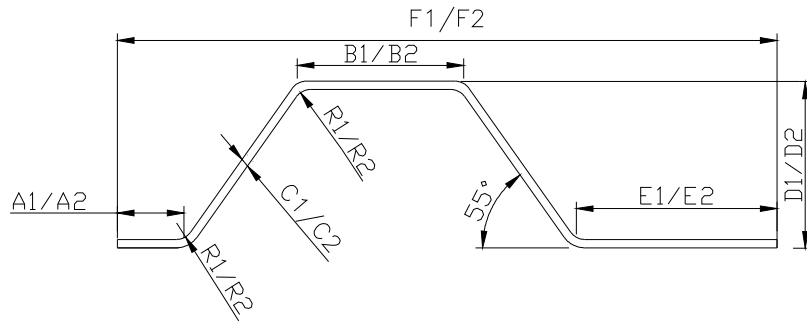

Ref: Drawing No. WD-10068- S-13, Item-21 & WD-10068-S-25, Item-6 (d)

Side Stanchion*			Date:			
SL. NO.	STAGE	Works Inspection	Inspecting Authority		Remarks	
1.	Dimensions	As follows				
	Location		Nominal Dimensions & Allowable Deviation	Actual Dimension		Remarks
				Works Inspection	Inspecting Authority	
i.	Left Flange	A1 A2	20 ± 1.25			
ii.	Right Flange	E1 E2	60 ± 1.25			
iii.	Top width	B1 B2	50 ± 1.00			
iv.	Bottom width	F1 F2	198 ± 1.50			
v.	Thickness	C1 C2	2.5 ± 0.20			
vi.	Height	D1 D2	50 ± 1.00			
vii.	Length	Top Bottom	562 ± 1.00			
viii.	Radius	R1 R2	4 ± 1.5			
ix.	Angle	-	± 1°15'			
x.	Waviness	-	2 max.			
xi.	Bow	-	1 in 600			
xii.	Camber	-	1 in 600			
xiii.	Twist	-	1 deg./metre			
xiv.	Appearance	-	Free from Deep Marks, Cracks, & Other Defects			

All dimensions are in mm

Works Inspector		Inspecting Authority	
Signature:		Signature:	
Name:		Name:	
Designation:		Designation:	
Date:		Date:	

End Coping Pressing

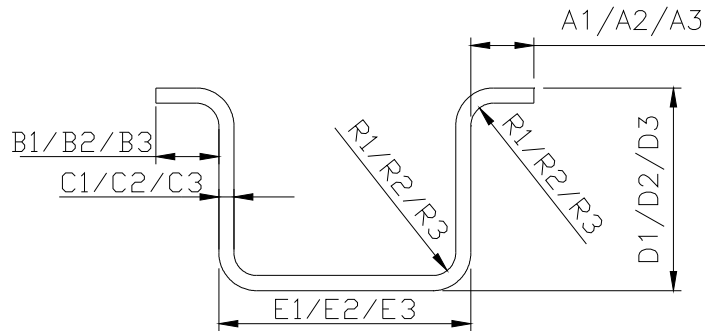

Ref: Drawing No. WD-10068- S-12, Item-10 & WD-10068-S-25, Item-7 (a)

End Coping Pressing				Date:		
SL. NO.	STAGE	Works Inspection		Inspecting Authority		Remarks
1.	Dimensions	As follows				
	Location		Nominal Dimensions & Allowable Deviation	Actual Dimension		Remarks
				Works Inspection	Inspecting Authority	
i.	Right Flange	A1	25 ± 1.25			
		A2				
		A3				
ii.	Left Flange	B1	25 ± 1.25			
		B2				
		B3				
iii.	Thickness	C1	6 ± 0.30			
		C2				
		C3				
iv.	Bottom width	E1	100 ± 1.00			
		E2				
		E3				
v.	Height	D1	80 ± 1.00			
		D2				
		D3				
vi.	Length	Top	3450 + 3 / - 1			
		Bottom				
vii.	Radius	R1	9 ± 1.5			
		R2				
		R3				
viii.	Angle	-	± 1°15'			
ix.	Waviness	-	2 max.			
x.	Bow	-	1 in 600			
xi.	Camber	-	1 in 600			
xii.	Twist	-	1 deg./metre			
xiii.	Appearance	-	Free from Deep Marks, Cracks, & Other Defects			

All dimensions are in mm

Works Inspector		Inspecting Authority	
Signature:		Signature:	
Name:		Name:	
Designation:		Designation:	
Date:		Date:	

End Top Stanchion

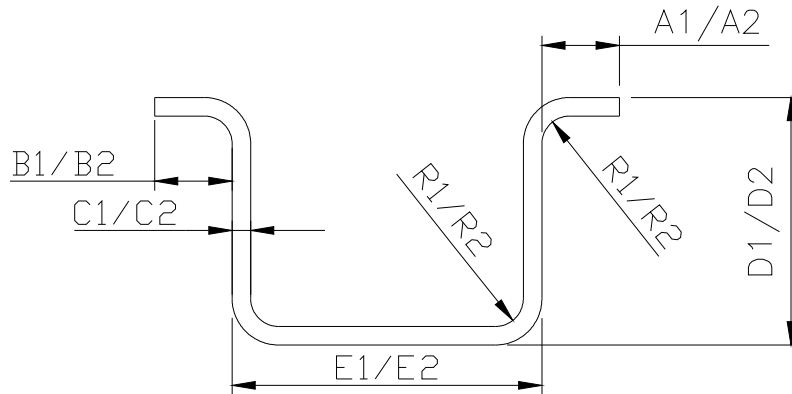

Ref: Drawing No. WD-10068- S-12, Item-08 & WD-10068-S-25, Item-7 (b)

End Coping Pressing			Date:			
SL. NO.	STAGE	Works Inspection	Inspecting Authority		Remarks	
1.	Dimensions	As follows				
	Location		Nominal Dimensions & Allowable Deviation	Actual Dimension		Remarks
				Works Inspection	Inspecting Authority	
i.	Right Flange	A1 A2	25 ± 1.25			
ii.	Left Flange	B1 B2	25 ± 1.25			
iii.	Thickness	C1 C2	6 ± 0.30			
iv.	Bottom width	E1 E2	100 ± 1.00			
v.	Height	D1 D2	80 ± 1.00			
vi.	Length	Top Bottom	860 ± 1.00			
vii.	Radius	R1 R2 R3	9 ± 1.5			
viii.	Angle	-	± 1°15'			
ix.	Waviness	-	2 max.			
x.	Bow	-	1 in 600			
xi.	Camber	-	1 in 600			
xii.	Twist	-	1 deg./metre			
xiii.	Appearance	-	Free from Deep Marks, Cracks, & Other Defects			

All dimensions are in mm

Works Inspector		Inspecting Authority	
Signature:		Signature:	
Name:		Name:	
Designation:		Designation:	
Date:		Date:	

End Stiffener Pressing Centre

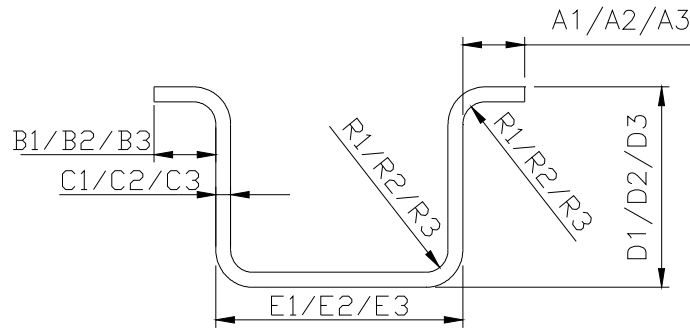

Ref: Drawing No. WD-10068- S-12, Item-11 & WD-10068-S-25, Item-7 (c)

End Coping Pressing				Date:		
SL. NO.	STAGE	Works Inspection	Inspecting Authority	Remarks		
1.	Dimensions	As follows				
	Location		Nominal Dimensions & Allowable Deviation	Actual Dimension		Remarks
				Works Inspection	Inspecting Authority	
i.	Right Flange	A1 A2 A3	25± 1.25			
ii.	Left Flange	B1 B2 B3	25± 1.25			
iii.	Thickness	C1 C2 C3	6 ± 0.30			
iv.	Bottom width	E1 E2 E3	100 ± 1.00			
v.	Height	D1 D2 D3	80 ± 1.00			
vi.	Length	Top Bottom	3354 + 3 / - 1			
vii.	Radius	R1 R2 R3	9 ± 1.5			
viii.	Angle	-	± 1°15'			
ix.	Waviness	-	2 max.			
x.	Bow	-	1 in 600			
xi.	Camber	-	1 in 600			
xii.	Twist	-	1 deg./metre			
xiii.	Appearance		Free from Deep Marks, Cracks, & Other Defects			

All dimensions are in mm

Works Inspector		Inspecting Authority	
Signature:		Signature:	
Name:		Name:	
Designation:		Designation:	
Date:		Date:	

Cross Member at Door (End)

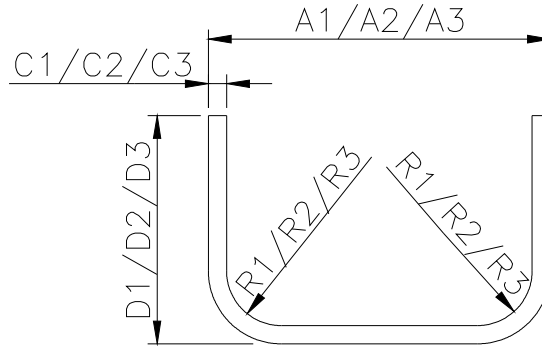

Ref: Drawing No. WD-10068- S-14, Item-06 & WD-10068-S-25, Item-8 (a)

Cross Member at Door (End)			Date:			
SL. NO.	STAGE	Works Inspection	Inspecting Authority		Remarks	
1.	Dimensions	As follows				
	Location		Nominal Dimensions & Allowable Deviation	Actual Dimension		Remarks
				Works Inspection	Inspecting Authority	
i.	Thickness	C1 C2 C3	4 ± 0.20			
ii.	Top width	A1 A2 A3	75 ± 1.00			
iii.	Height	D1 D2 D3	50 ± 1.25			
iv.	Length	Top Bottom	1521 ± 1.00			
v.	Radius	R1 R2 R3	6 ± 1.5			
vi.	Angle	-	± 1°15'			
vii.	Waviness	-	2 max.			
viii.	Bow	-	1 in 600			
ix.	Camber	-	1 in 600			
x.	Twist	-	1 deg./metre			
xi.	Appearance	-	Free from Deep Marks, Cracks, & Other Defects			

All dimensions are in mm

Works Inspector		Inspecting Authority	
Signature:		Signature:	
Name:		Name:	
Designation:		Designation:	
Date:		Date:	

Cross Member (Middle)

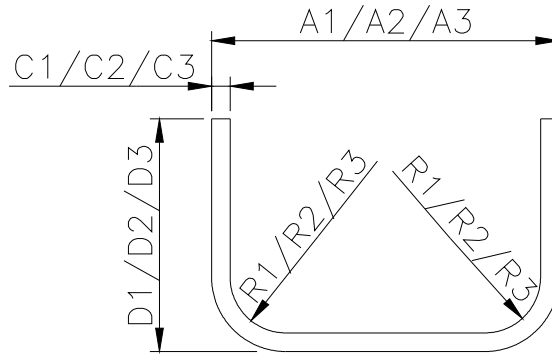

Ref: Drawing No. WD-10068- S-14, Item-07 & WD-10068-S-25, Item-8 (b)

Cross Member at Door (End)			Date:			
SL. NO.	STAGE	Works Inspection	Inspecting Authority		Remarks	
1.	Dimensions	As follows				
	Location		Nominal Dimensions & Allowable Deviation	Actual Dimension		Remarks
				Works Inspection	Inspecting Authority	
i.	Thickness	C1 C2 C3	4 ± 0.20			
ii.	Top width	A1 A2 A3	75 ± 1.00			
iii.	Height	D1 D2 D3	50 ± 1.25			
iv.	Length	Top Bottom	1052 ± 1.00			
v.	Radius	R1 R2 R3	6 ± 1.5			
vi.	Angle	-	± 1°15'			
vii.	Waviness	-	2 max.			
viii.	Bow	-	1 in 600			
ix.	Camber	-	1 in 600			
x.	Twist	-	1 deg./metre			
xi.	Appearance	-	Free from Deep Marks, Cracks, & Other Defects			

All dimensions are in mm

Works Inspector		Inspecting Authority	
Signature:		Signature:	
Name:		Name:	
Designation:		Designation:	
Date:		Date:	

Cross Member (End)

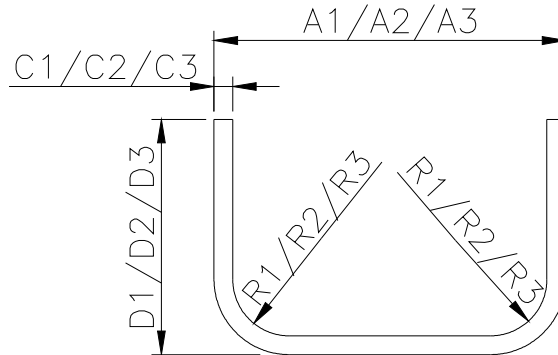

Ref: Drawing No. WD-10068- S-14, Item-06 & WD-10068-S-25, Item-8 (c)

Cross Member at Door (End)				Date:		
SL. NO.	STAGE	Works Inspection		Inspecting Authority		Remarks
1.	Dimensions	As follows				
	Location		Nominal Dimensions & Allowable Deviation	Actual Dimension		Remarks
				Works Inspection	Inspecting Authority	
i.	Thickness	C1 C2 C3	4 ± 0.20			
ii.	Top width	A1 A2 A3	75 ± 1.00			
iii.	Height	D1 D2 D3	50 ± 1.25			
iv.	Length	Top Bottom	1618 ± 1.00			
v.	Radius	R1 R2 R3	6 ± 1.5			
vi.	Angle	-	± 1°15'			
vii.	Waviness	-	2 max.			
viii.	Bow	-	1 in 600			
ix.	Camber	-	1 in 600			
x.	Twist	-	1 deg./metre			
xi.	Appearance	-	Free from Deep Marks, Cracks, & Other Defects			

All dimensions are in mm

Works Inspector		Inspecting Authority	
Signature:		Signature:	
Name:		Name:	
Designation:		Designation:	
Date:		Date:	

Longitude of Roof

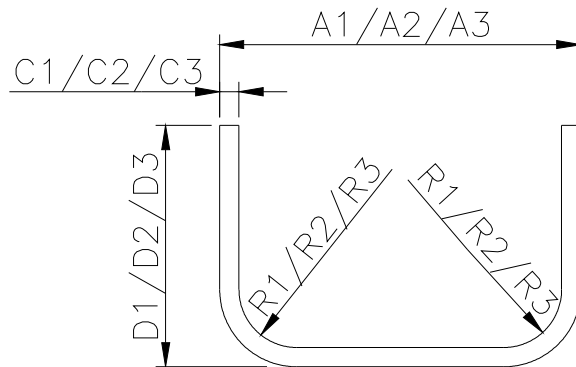

Ref: Drawing No. WD-10068- S-14, Item-08 & WD-10068-S-25, Item-9

Cross Member at Door (End)				Date:		
SL. NO.	STAGE	Works Inspection		Inspecting Authority		Remarks
1.	Dimensions	As follows				
	Location		Nominal Dimensions & Allowable Deviation	Actual Dimension		Remarks
				Works Inspection	Inspecting Authority	
i.	Thickness	C1 C2 C3	4 ± 0.20			
ii.	Top width	A1 A2 A3	75 ± 1.00			
iii.	Height	D1 D2 D3	50 ± 1.25			
iv.	Length	Top Bottom	10034+ 4 / - 2			
v.	Radius	R1 R2 R3	6 ± 1.5			
vi.	Angle	-	± 1°15'			
vii.	Waviness	-	2 max.			
viii.	Bow	-	1 in 600			
ix.	Camber	-	1 in 600			
x.	Twist	-	1 deg./metre			
xi.	Appearance	-	Free from Deep Marks, Cracks, & Other Defects			

All dimensions are in mm

Works Inspector		Inspecting Authority	
Signature:		Signature:	
Name:		Name:	
Designation:		Designation:	
Date:		Date:	

Corner Stanchion

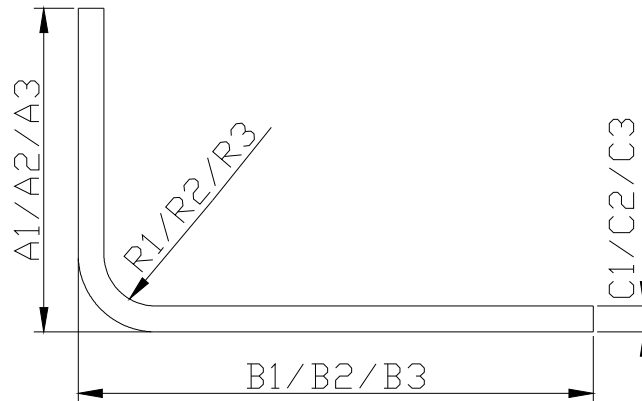

Ref: Drawing No. WD-10068- S-14, Item-01 & WD-10068-S-25, Item-10

Corner Stanchion			Date:			
SL. NO.	STAGE	Works Inspection	Inspecting Authority		Remarks	
1.	Dimensions	As follows				
	Location		Nominal Dimensions & Allowable Deviation	Actual Dimension		Remarks
				Works Inspection	Inspecting Authority	
i.	Thickness	C1 C2 C3	8 ± 0.40			
ii.	Bottom width	B1 B2 B3	160 ± 1.5			
iii.	Height	A1 A2 A3	100 ± 1.5			
iv.	Length	Top Bottom	2180 + 3.0 / - 1.0			
v.	Radius	R1 R2 R3	16 ± 1.5			
vi.	Angle	-	± 1°15'			
ix.	Waviness	-	2 max.			
x.	Bow	-	1 in 600			
xi.	Camber	-	1 in 600			
xii.	Twist	-	1 deg./metre			
xiii.	Appearance	-	Free from Deep Marks, Cracks, & Other Defects			

All dimensions are in mm

Works Inspector		Inspecting Authority	
Signature:		Signature:	
Name:		Name:	
Designation:		Designation:	
Date:		Date:	

Side Top Coping (End)

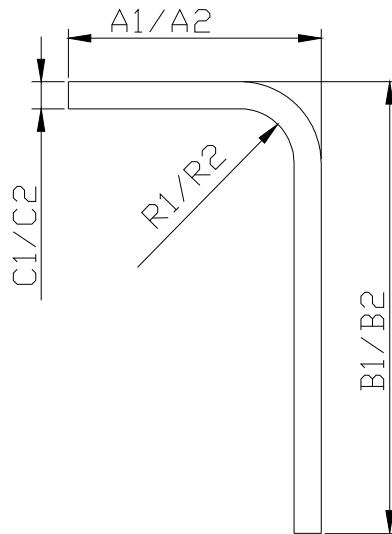

Ref: Drawing No. WD-10068- S-14, Item-03 & WD-10068-S-25, Item-11 (a)

Side Top Coping (End)				Date:		
SL. NO.	STAGE	Works Inspection		Inspecting Authority		Remarks
1.	Dimensions	As follows				
	Location		Nominal Dimensions & Allowable Deviation	Actual Dimension		Remarks
				Works Inspection	Inspecting Authority	
i.	Thickness	C1 C2	6 ± 0.30			
ii.	Top width	A1 A2	56 ± 1.25			
iii.	Height	B1 B2	100 ± 1.5			
iv.	Length	Top Bottom	491 ± 1.0			
v.	Radius	R1 R2	12 ± 1.5			
viii.	Angle	-	± 1°15'			
ix.	Waviness	-	2 max.			
x.	Bow	-	1 in 600			
xi.	Camber	-	1 in 600			
xii.	Twist	-	1 deg./metre			
xiii.	Appearance	-	Free from Deep Marks, Cracks, & Other Defects			

All dimensions are in mm

Works Inspector		Inspecting Authority	
Signature:		Signature:	
Name:		Name:	
Designation:		Designation:	
Date:		Date:	

Side Top Coping (Middle)

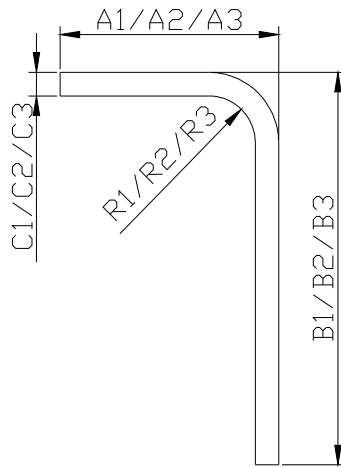

Ref: Drawing No. WD-10068- S-14, Item-04 & WD-10068-S-25, Item-11 (b)

Side Top Coping (End)			Date:		
SL. NO.	STAGE	Works Inspection	Inspecting Authority		Remarks
1.	Dimensions	As follows			
	Location		Nominal Dimensions & Allowable Deviation	Actual Dimension	
				Works Inspection	Inspecting Authority
i.	Thickness	C1 C2 C2	6 ± 0.30		
ii.	Top width	A1 A2 A3	56 ± 1.25		
iii.	Height	B1 B2 B3	100 ± 1.5		
iv.	Length	Top Bottom	4036 +3.0 / - 1.0		
v.	Radius	R1 R2 R3	12 ± 1.5		
viii.	Angle	-	± 1°15'		
ix.	Waviness	-	2 max.		
x.	Bow	-	1 in 600		
xi.	Camber	-	1 in 600		
xii.	Twist	-	1 deg./metre		
xiii.	Appearance	-	Free from Deep Marks, Cracks, & Other Defects		

All dimensions are in mm

Works Inspector		Inspecting Authority	
Signature:		Signature:	
Name:		Name:	
Designation:		Designation:	
Date:		Date:	

End Stanchion (Bottom)

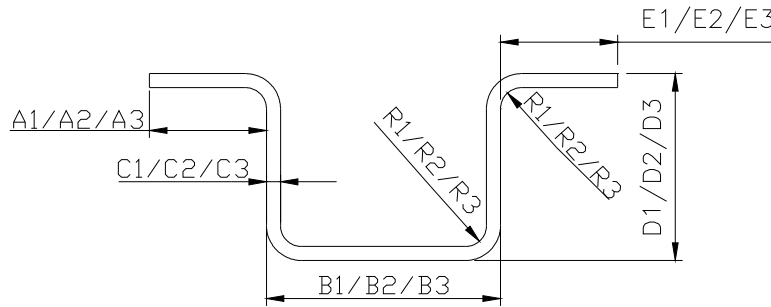

Ref: Drawing No. WD-10068- S-12, Item-07 & WD-10068-S-25, Item-12 (a)

End Stanchion (Bottom)			Date:		
SL. NO.	STAGE	Works Inspection	Inspecting Authority		Remarks
1.	Dimensions	As follows			
	Location	Nominal Dimensions & Allowable Deviation	Actual Dimension		Remarks
			Works Inspection	Inspecting Authority	
i.	Left Flange	A1 A2 A3	55 ± 1.25		
ii.	Right Flange	E1 E2 E3	55 ± 1.25		
iii.	Thickness	C1 C2 C3	6 ± 0.30		
iv.	Bottom width	B1 B2 B3	100 ± 1.00		
v.	Height	D1 D2 D3	80 ± 1.00		
vi.	Length	Top Bottom	1201 ± 1.00		
vii.	Radius	R1 R2 R3	9 ± 1.5		
viii.	Angle	-	± 1°15'		
ix.	Waviness	-	2 max.		
x.	Bow	-	1 in 600		
xi.	Camber	-	1 in 600		
xii.	Twist	-	1 deg./metre		
xiii.	Appearance	-	Free from Deep Marks, Cracks, & Other Defects		

All dimensions are in mm

Works Inspector		Inspecting Authority	
Signature:		Signature:	
Name:		Name:	
Designation:		Designation:	
Date:		Date:	

End Stanchion (Middle)

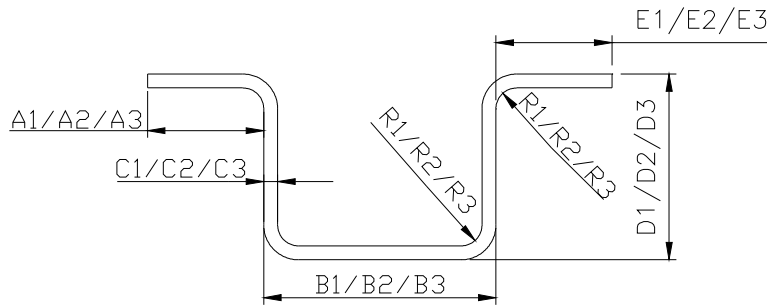

Ref: Drawing No. WD-10068- S-12, Item-05 & WD-10068-S-25, Item-12 (b)

End Stanchion (Bottom)				Date:	
SL. NO.	STAGE	Works Inspection	Inspecting Authority	Remarks	
1.	Dimensions	As follows			
	Location	Nominal Dimensions & Allowable Deviation	Actual Dimension		Remarks
			Works Inspection	Inspecting Authority	
i.	Left Flange	A1 A2 A3	55 ± 1.25		
ii.	Right Flange	E1 E2 E3	55 ± 1.25		
iii.	Thickness	C1 C2 C3	6 ± 0.30		
iv.	Bottom width	B1 B2 B3	100 ± 1.00		
v.	Height	D1 D2 D3	80 ± 1.00		
vi.	Length	Top Bottom	874 ± 1.00		
vii.	Radius	R1 R2 R3	9 ± 1.5		
viii.	Angle	-	± 1°15'		
ix.	Waviness	-	2 max.		
x.	Bow	-	1 in 600		
xi.	Camber	-	1 in 600		
xii.	Twist	-	1 deg./metre		
xiii.	Appearance	-	Free from Deep Marks, Cracks, & Other Defects		

All dimensions are in mm

Works Inspector		Inspecting Authority	
Signature:		Signature:	
Name:		Name:	
Designation:		Designation:	
Date:		Date:	

Corner Roof Carline

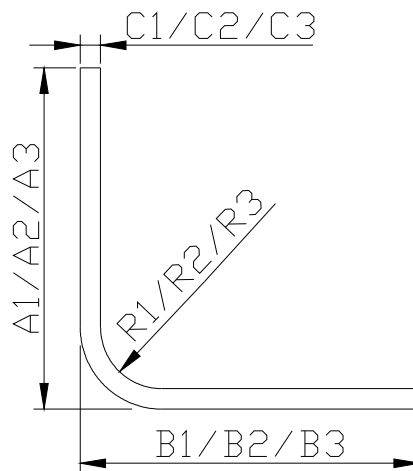

Ref: Drawing No. WD-10068- S-14, Item-09 & WD-10068-S-25, Item-13

Corner Roof Carline*			Date:		
SL. NO.	STAGE	Works Inspection	Inspecting Authority		Remarks
1.	Dimensions	As follows			
	Location		Nominal Dimensions & Allowable Deviation	Actual Dimension	Remarks
				Works Inspection	Inspecting Authority
i.	Thickness	C1 C2 C3	6 ± 0.30		
ii.	Bottom width	B1 B2 B3	100 ± 1.25		
iii.	Height	A1 A2 A3	100 ± 1.25		
iv.	Length	Top Bottom	4236 + 3.0 / - 1.0		
v.	Radius	R1 R2 R3	12 ± 1.5		
viii.	Angle	-	± 1°15'		
ix.	Waviness	-	2 max.		
x.	Bow	-	1 in 600		
xi.	Camber	-	1 in 600		
xii.	Twist	-	1 deg./metre		
xiii.	Appearance	-	Free from Deep Marks, Cracks, & Other Defects		

All dimensions are in mm

Works Inspector		Inspecting Authority	
Signature:		Signature:	
Name:		Name:	
Designation:		Designation:	
Date:		Date:	

Sampling plan											
S. No	Component s/ Operation /Product/ Process		Characteristics/ Parameters	Mode of Inspection/ Equipments	Internal Inspection Sample-		Reference documents/ Specification	Acceptance Criteria	Documents of Records	RDSO Inspection Sample-	
					Size	Frequency				Size	Frequency
1	Raw Material Receipt	a)	Source of Procurement	Visual	-	Every lot	Receipt Particulars & RDSO's Vendor List	Should be procured from RDSO approved sources only	Format no....	-	Every Lot
		b)	System of Unloading	Visual	Complete Lot	Every lot	Nil	No external damage should occur		AUDIT	
		c)	Quantity	Visual	Complete Lot	Every lot	Receipt particulars	To be as per receipt particulars			
		d)	Weight	Weighing Machine	One/Lot	Every lot					
2	Raw Material Inspection	a)	Identification of Coil/plate	Visual	Every coil/plate	Every coil/ plate	T.C.	Coil No. & Heat No. to be as per T.C.	Format no---	AUDIT	
		b)	Coil/Strip width & thickness	Measuring Tape/Steel Rule/ Micrometer	One per Coil/Plate	3 times (start, middle, end) of coil/plate	Indent & T.C.	To be as per indent/design requirement		Complete Lot	Every lot
		c)	Grade	By means of suitable m/c / test equipment in house lab/NABL approved lab	Complete Lot	Every lot	Indent & T.C.	To be as per indent/design requirement			
		d)	Mechanical Properties		Complete Lot	Every lot	Indent & T.C.	To be as per prescribed specification			
		e)	Chemical Properties		Complete Lot	Every lot	Indent & T.C.	To be as per prescribed specification			
		f)	Bend Test		Complete Lot	Every lot	Indent & T.C.	To be as per prescribed specification			
		g)	Testing of Mechanical & Chemical Properties and Bend Testing	One/Lot	Every lot	Prescribed specification	To be as per prescribed specification	Format no....		2 (1 to be tested & 1 to be stored)	Every lot or at an interval of three months, whichever is later
3	Raw Material & Final Product Storage	a)	Condition of storage area	visual	Complete lot	Daily	WD-01-CRF-08 with latest alt.	Covered area and protection from water	Format no---	AUDIT	
		b)	Availability of Racks/Packing					Proper racks and packing to be available			
		c)	Condition of Material					To be free from damages, dents & rust.			
4	Selection of coil for slitting	a)	Condition of Coil	Visual	Complete coil/plate	Every coil/ plate	-	Coil/plate to be free from damage & rust	Format no---	AUDIT	

S. No	Component s/ Operation /Product/ Process		Charcteristics/ Parameters	Mode of inspection/ equipments	Internal inspection sample		Ref documents/ specifications	Acceptance criteria	Documents of records	RDSO inspection Sample	
					Size	Frequency				Size	Frequ ency
5	Handling of coil/plates/Sections till despatch	a)	Care during movement	Visual	Every coil/ plate/Section	Every coil/ plate/section	-	No damage/dent to occur	Format no---	AUDIT	
6	Coil/plate slitting	a)	Coil/Plate width	Measuring Tape/ Steel Rule/Vernier	One per Coil/Plate	3 times (start, middle, end) of coil/plate	Design requirement	To be as per design requirement	Format no---	AUDIT	
		b)	Edge condition	Visual	Complete slitted Coil/Plate	Every slitted Coil/ Plate	Should be smooth	To be free from burrs, sharp edges			
7	Setting of rolls on mill	a)	Correctness of rolls	Visual/Measuring Tape/ Steel Rule/Vernier	Every rolling mill	Twice in one shift		All rolls to be as per design requirement	Format no---	AUDIT	
8	In-process Inspection	a)	Profile of the section	Measuring tape, Vernier, Bevel protactor, Radius gauge	1 no.	3 times (start,middle, end) of coil/plate	Respective RDSO/P.O. drawing/check sheet	To be as per respective RDSO/P.O. drawing/check sheet	Format no---	AUDIT	
		b)	Marking of Coil/plate no.	Visual	1 no.	Every coil/plate	-	To be same as the selected coil	Format no---	AUDIT	
9	Post Roll Forming Operations	a)	Drilling	Vernier/Gauge	1 no.	Every section	Respective RDSO/P.O. drawing/check sheet	To be as per respective RDSO/P.O. drawing/check sheet	Format no---	AUDIT	
		b)	Notching	Visual							
		c)	Edge Preparation	Visual							
		d)	Profile cutting	Visual							
10	Welding	a)	Weld Preparation, Fixtures, Welding machine and current/voltage, welding electrodes, weld cleaning and condition of weld	Visual, Radiography (if, prescribed)	10%	Every lot	WPS, issued by RDSO	To be as per WPS, issued by RDSO	Format no---	5% (Minimum two set)	Each lot
11	Final Inspection	a)	Profile of the section	Measuring tape, Vernier, Bevel protactor, Radius gauge	10%	Every lot	Respective RDSO/P.O. drawing/check sheet	To be as per respective RDSO/P.O. drawing/check sheet	Format no---	5% (Minimum two set)	Each lot
		b)	Edge condition	Visual	10%	Every lot	Respective RDSO/P.O. drawing/check sheet	To be as per respective RDSO/P.O. drawing/check sheet and free from burrs & sharp edges	Format no---	5% (Minimum two set)	Each lot
		c)	Drilling	Plug Gauge/ Vernier	1 no.	Every section	Respective RDSO/P.O. drawing/check sheet	To be as per respective RDSO/P.O. drawing/check sheet	Format no---	AUDIT	
		d)	Notching	Visual							
		e)	Edge Preparation	Visual							
		f)	Profile cutting	Visual							

S. No	Component s/Operation/ Product/ Process		Characteristics/ parameters	Mode of inspection/ Equipments	Internal inspection sample		Reference documents/ specification	Acceptance criteria	Documents of records	RDSO inspection sample	
					Size	Frequency				Size	Frequen cy
12	Marking	a)	Correctness of marking	Visual	10%	Every lot	-	Month and year to be current and Coil No. to be same as Original No.	Format no---	5% (Minimum two set)	Each lot
		b)	Legibility of Marking	Visual	10%	Every lot	-	To be legible	Format no---	5% (Minimum two set)	Each lot
13	Linking of punched Coil No. with Grade of Material	a)	Material Properties	Visual	10%	Every lot	T.C. and lab Results	To be as per respective RDSO specification	Format no---	5% (Minimum two set)	Each lot
14	Packing of sections	a)	Condition of Packing	Visual	10%	Every lot	-	Packing to be sturdy and Marking on Packing should contain complete identification details of the Products	Format no---	Minimum Two packs	Each lot
		b)	Marking on Packing								
		c)	Condition of Packed Products								