

INDIAN RAILWAYS



सत्यमेव जयते

CHECK SHEETS

FOR

BOGIE OPEN WAGON

TYPE – BOYEL

S.No.	Month & Year of issue	Revision / Amendment	Page No.	Reason for Amendment
1.	Jan 2018	First issue	-	-

ISSUED BY

RESEARCH DESIGNS AND STANDARDS ORGANISATION
MINISTRY OF RAILWAYS

LUCKNOW-226 011

CONTENTS

Description	Page No
Centre Sill	3
Centre filler/Pivot filler	4
Underframe	5
Body End	6
Body Side	7
Final Assembly	8
BMBS Clearance in assembled wagon(Brake Released)	9
Final Wagon	10
Other attributes	11
Performance for Single wagon air brake test	12-13

Note:

These check sheets do not detail all the dimensions or technical requirements of respective wagon assemblies/components.

These check sheets are issued only for General Guidance & assistance of inspecting officials. Notwithstanding the above, the inspecting officials are advised to refer to relevant drawings and/or relevant specifications to confirm conformity to the specified dimensions and technical details.

CENTRE SILL

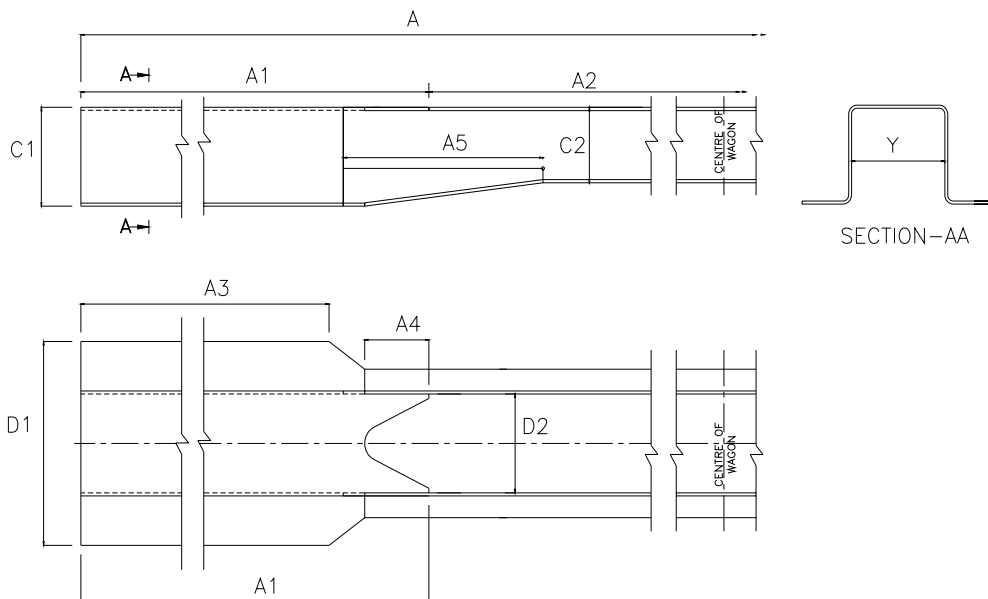

CENTRE SILL NO:		Date:		
SL. NO.	STAGE	Works Inspection	RDSO Inspection	Remarks
1.	Centre Sill 'Hat' section.			
1.1	Fitment of all components			
1.2	Welding			
1.3	Dressing			
1.4	Lock Bolting			
2.	Dimensions		As follows	
	LOCATION		Nominal Dimensions & Allowable Deviation	Actual Dimension
				Works Inspection
				RDSO Inspection
i.	Length	A	11000, +4, -2	
		A1	2455, +1, -1	
		A2	6090, +2, -1	
		A3	2105, +1, -1	
		A4	225, +1, -1	
ii.	Height	C1	327, ±1.5	
		C2	250, ±2	
iii.	Width	D1	674, ±3	
		D2	327, +3, -0	
iv.	Draft Gear Pocket	Y	327, +3, -0	

Works Inspector		RDSO Inspector	
Signature:		Signature:	
Name:		Name:	
Designation:		Designation:	
Date:		Date:	

Centre Filler/Pivot Filler

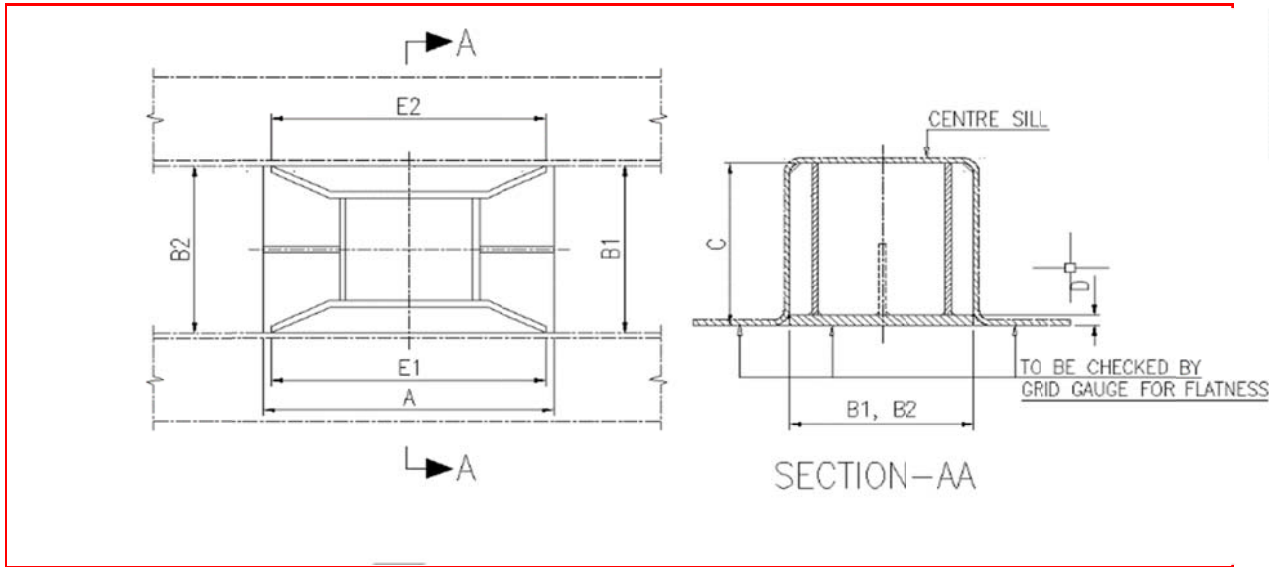

Sl. No.	STAGE	Works Inspector	RDSO Inspector	Remarks	
1	Fitment of all components				
2	Welding				
3	Dressing				
4	Dimensions		As follows		
	LOCATION		Nominal Dimensions & Allowable Deviation	Actual Dimension	Remarks
				Works Inspector	RDSO Inspector
i	Length of base plate	A	520 ±1		
ii	Overall width at center position	B1 B2	330+3-0		
iii	Assembly height of Pivot filler	C	315 +0, -2		
iv	Thickness of base plate	D	20		
v	Length of Pivot Filler Support web plate at bending condition	E1 E2	400 ±1		
vi	Flatness of Pivot Filler Top & Centre Sill after welding	-	Filler Gauge of 0.76 mm. should not pass below grid gauge.		

Note : Centre filler base plate edge preparation should be checked properly

Works Inspector		RDSO Inspector	
Signature:		Signature:	
Name:		Name :	
Designation:		Designation:	
Date		Date:	

UNDEFRAME

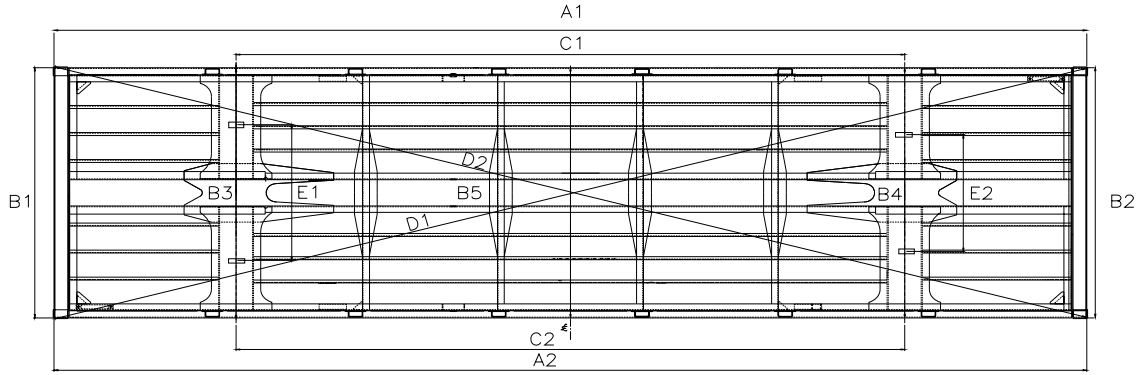

UNDERFRAME NO:		Date:			
SL. NO.	STAGE	Works Inspection	RDSO Inspection	REMARKS	
1.	Fitment of all components				
2.	Welding				
3.	Dressing				
4.	Dimensions	As follows			
	LOCATION		Nominal Dimensions & Allowable Deviation	Actual Dimension	Remarks
				Works Inspection	RDSO Inspection
i.	Length over head stock	A1	11000, +4,-2		
		A2			
ii.	Width over solebar	B1	2934±3		
		B2			
		B3			
		B4			
		B5			
iii.	Distance between bolster bogie centre	C1	7330, +5,-2		
		C2			
iv)	Distance between side bearers centre	E1	1474±2		
		E2			
v)	Diagonal difference over headstock	D1	≤ 5		
		D2			
vi)	Difference between side bearer top liner and CP top		10.8,+0,-0.5		
	Camber		10±2		

Works Inspector		RDSO Inspector	
Signature:		Signature:	
Name:		Name:	
Designation:		Designation:	
Date:		Date:	

BODYEND

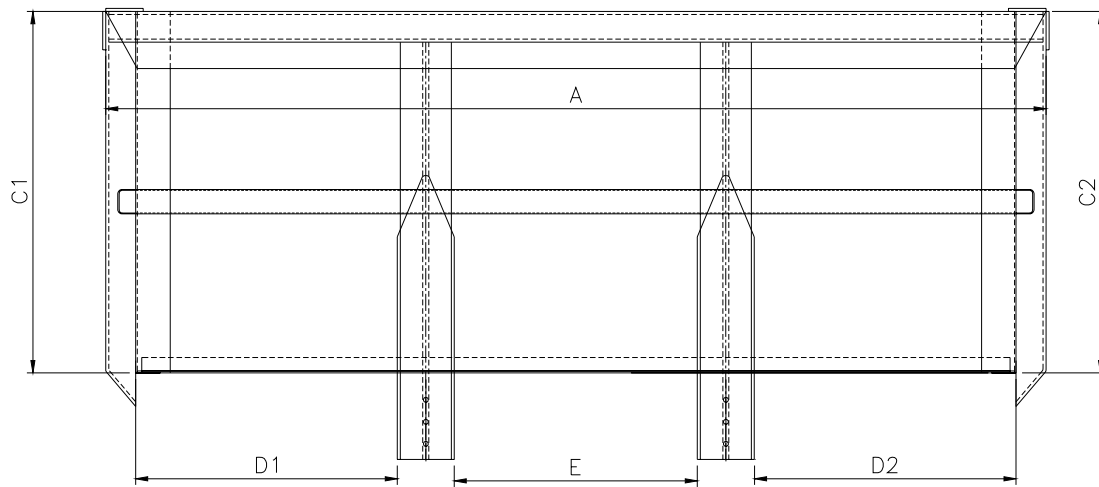

BODY END NO:		Date:				
SL. NO.	STAGE	Works Inspection	RDSO Inspection	Remarks		
1.	Fitment of all components					
2.	Welding					
3.	Dressing					
4.	Dimensions	As follows				
	LOCATION		Nominal Dimensions & Allowable Deviation	Actual Dimension		Remarks
				Works Inspection	RDSO Inspection	
i.	Width over corner stanchions	A	2954, +3 -0			
ii.	End Wall overall height	C1	1171± 3			
		C2				
iii.	Distance between corner angle to stanchion	D1	892± 1.5			
		D2				
iii.	Distance between stanchions	E	830± 1.5			

Works Inspector		RDSO Inspector	
Signature:		Signature:	
Name:		Name:	
Designation:		Designation:	
Date:		Date:	

BODYSIDE

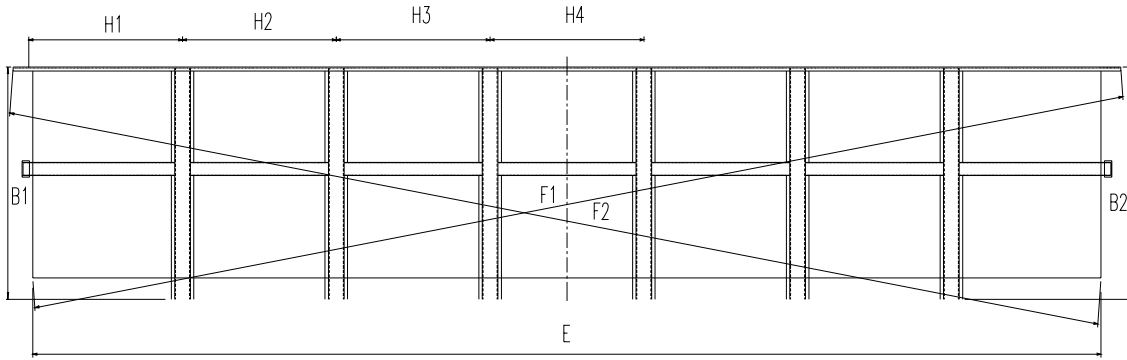

BODY SIDE NO:						
Date:						
SL. NO	STAGE	Works Inspection		RDSO Inspection	Remarks	
1.	Fitment of all components					
2.	Welding					
3.	Dressing					
4.	Dimensions			As follows		
	LOCATION	Nominal Dimensions & Allowable Deviation		Actual Dimension		Remarks
				Works Inspection	RDSO Inspection	
i.	Side Wall Overall Height	B1	1426±3			
		B2				
iii.	Distance between side plate end to end	E	10950+7,-3			
iv.	Diagonal difference over corner	F1	≤ 5			
		F2				
v.	Distance between stanchion at dummy quarter	H1	1570± 3			
		H2				
		H3				
		H4				

Works Inspector		RDSO Inspector	
Signature:		Signature:	
Name:		Name:	
Designation:		Designation:	
Date:		Date:	

FINAL ASSEMBLY

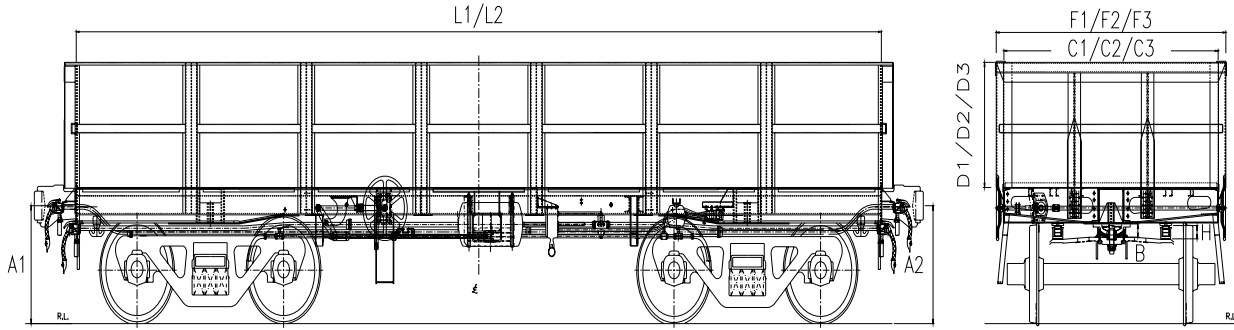

Wagon No.:		U/F No.:		Date:		
SL. NO.	STAGE	Works Inspection	RDSO Inspection	Remarks		
1.	Fitment of all components					
2.	Lock Bolting					
3.	Welding					
4.	Operation of Doors					
5.	Operation of Couplers					
6.	Under gear Examination					
7.	Brake test i) Air brake ii) Hand brake					
8.	Painting					
9.	Lettering					
10.	RFID(Fitment/Location/ Data Entry)					
11.	Dimensions	As follows				
	LOCATION		Nominal Dimensions & Allowable Deviation	Actual Dimension		Remarks
				Works Inspection	RDSO Inspection	
i.	Coupler height from R.L	A1 A2	1105, +0, -5			
ii.	Length Inside	L1 L2	10990, +4, -2			
iii.	Width Inside	C1 C2 C3	2924, ± 3			
iv.	Height Inside (Floor level to top)	D1 D2 D3	1175, ± 3			
v.	Overall Width	F1 F2 F3	3134, ± 3			
vi.	Centre pivot assembled height	B1 B2	120, +2, -0			
vii.	Side bearer set up height from bolster seat	H1,H2 H3,H4	124.2, +0.5, -0			

Works Inspector		RDSO Inspector	
Signature:		Signature:	
Name:		Name:	
Designation:		Designation:	
Date:		Date:	

Check sheet for BMBS Clearance in assembled CASNUB Bogie
(Brakeinreleasedcondition)

Wagon No. Bogie
No.: (1)

Sr. No.	Description	Min Value in mm	Measured value.	
1.	Clearance between push rod and spring plank.	10	L	
			R	
2.	Total Clearance between bell crank levers and wheel faces (i.e Total of left & right side)	80 Min. 20 (if measured on any one side.)	L	
			R	
			Total	
3.	Total Clearance (i.e sum of clearances) between 3.1 Spring plank & primary brake beam and 3. 2 Spring plank & secondary brake beam.	77	L	
			R	
			Total	
4.	Clearance between brake cylinder & brake beam.	30		

Bogie No.(2)

Sr. No.	Description	Min Value in mm	Measured value.	
1.	Clearance between push rod and spring plank.	10	L	
			R	
2.	Total Clearance between bell crank levers and wheel faces (i.e Total of left & right side)	80 Min. 20 (if measured on any one side.)	L	
			R	
			Total	
3.	Total Clearance (i.e sum of clearances) between 3.1 Spring plank & primary brake beam and 3. 2 Spring plank & secondary brake beam.	77	L	
			R	
			Total	
4.	Clearance between brake cylinder & brake beam.	30		

Works Inspector		RDSO Inspector	
Signature:		Signature:	
Name:		Name:	
Designation:		Designation:	
Date:		Date:	

FINAL WAGON

1.	Wagon No.		2.	Date of offer	
3.	Underframe No.		4.	Name of the Wagon Manufacturer:	
5.	Contract/P.O. placed by		6.	Contract/P.O. No. and date and D.P. (Upto)	
7.	Running Gear				
a)	Bearing Make			Serial Nos.	
b)	Wheel Make			Serial Nos.	
c)	Axle Make			Serial Nos.	
d)	Bogie Make & Sr. Nos.		e)	Air Brake Make	
f)	PU Pad make		h)	Aux. Reservoir make	
g)	DV Make & Sr. no.		i)	Date of air brake testing	
j)	Date of SWTR calibration		k)	Coupler Make & Sr. Nos.	
8.	Draft Gear Make, Model & Sr. Nos.		9.	Tare Weight	
10.	CRF section make		11.	Lock Bolt Make	
12.	Paint Make		13.	D.M. Issue date	
14.	TXR fit memo issue date		15.	CBB make & Sr. Nos.	
16.	Brake Cylinder Make & Sr. Nos.		17.	Shot blasting	
18.	APM Make & Sr. No.		19.	RFID Tag	

19. RAD availed _____

20. Defects Observed _____

Works Inspector		RDSO Inspector	
Signature:		Signature:	
Name:		Name:	
Designation:		Designation:	
Date:		Date:	

Other attributes

Wagon No.:		U/F No.:	Date:	
SL NO.	ATTRIBUTES	ACCEPTANCE LIMIT	WORKS INSPN.	RDSO INSPN.
1.	Check paint- for finish			
2.	Lettering & marking- for legibility, size, location & punch mark.	As per Drg No.WD-06084-S-02 with latest alt.		
3.	COUPLER			
3.1	Height from Rail Level	1105 +0, - 5		
3.2	Operation of knuckle with operating handle	Full knuckle throw lock to lock		
3.3	Articulation of coupler body	Free movement		
4.	HAND BRAKE			
4.1	Apply hand brake (by one person only and strike all wheels with a Hammer)	There should not be ringing sound		
4.2	Release the hand brake and apply crow bar on one end of brake block to take up all slack	All brake blocks must be released. Gap between the brake block and wheel tread not to be less than 23.6 mm (5.9 x 4) -		

Works Inspector		RDSO Inspector	
Signature:		Signature:	
Name:		Name:	
Designation:		Designation:	
Date:		Date:	

PROFORMA FOR SINGLE WAGON AIR BRAKE TEST

Wagon No..... Bogie Make.....DV Make.....

S.No.	Check	Specified	Actual
1	Pressure in BP	5 ± 0.1 kg/sq.cm.	
1.a	Pressure in FP	6 ± 0.1 kg/sq.cm. (twin pipe)	
2	Pressure in AR	5 ± 0.1 kg/sq.cm.(for single pipe) 6 ± 0.1 kg/sq.cm. (for twin pipe)	
3	Leakage from the system in one minute.	0.1 kg/sq. cm.(max.)	
4	Full service application after charging		
4.1	Brake cylinder filling time		
	a) Empty (Pressure rise from 0 to 2.1 kg/sq.cm.)	18 to 30 sec	
	b) Loaded (Pressure rise from 0 to 3.6 kg/sq.cm.)	18 to 30 sec.	
4.2	Maximum brake cylinder pressure		
	a) Empty	2.2 ± 0.25 kg/sq.cm.	
	b) Loaded	3.8 ± 0.1 kg/sq.cm.	
4.3	Reduction in BP pressure required for full service application.	1.3 to 1.6 kg/sq.cm.	
5	Release after full service application.		
5.1	Draining time (Brake cylinder pressure to fall from 2.2 ± 0.25 kg/sq.cm. to 0.4kg/sq.cm.in empty condition & 3.8 ± 0.1 kg/sq.cm to 0.4 kg/sq.cm in loaded condition)		
	a) Empty	45 to 60 sec	
	b) Loaded	45 to 60 sec.	
6	Sensitivity of brakes. Isolate brake pipes from mainline. Check the response of brakes when brake pipe pressure is reduced at the most equal to 0.6 kg/sq.cm. in 6 sec.	Brake should apply within 6 sec.	
7	Insensitivity of brakes, isolate brake pipe from mainline. Check the pressure of brakes when brake pipe pressure is reduced at least equal to 0.3 kg/sq.cm. in 60 sec.	Brake should not apply	
8	Emergency application:		
8.1	Brake cylinder filling time		
	a) Empty (Pressure rise from 0 to 2.1 kg/sq.cm.)	18 to 30 sec.	
	b) Loaded (Pressure rise from 0 to 3.6 kg/sq.cm.)	18 to 30 sec.	
8.2	Maximum brake cylinder pressure		
	a) Empty	2.2 ± 0.25 kg/sq.cm.	
	b) Loaded	3.8 ± 0.1 kg/sq.cm.	
9	Piston stroke		
	1)M/S Knorr, Medha, Prag System (Empty)	54 ± 10 mm	
	2)Escorts,GDR,ADEPL System (Empty)	55 ± 10 mm	
	(Loaded)	70 ± 10 mm	
10	Leakage from brake cylinder after emergency application.	0.1 kg/sq.cm. (max.) within 5 minutes	

11	Automatic exhausting of brake cylinder and control chamber.		
11.1	Apply emergency brakes (i.e. BP=0kg/sq.cm). Check the brake cylinder pressure after giving a brief pull to release hook.	Brake cylinder and control reservoirs should exhaust automatically.	
12	Empty load change over by APM Device		
12.1	Unrestricted movement of lever arm APM Device.	Brake cylinder pressure 2.2± 0.25 kg/sq.cm.	
12.2	Restrict the movement of lever arm of APM Device by more than 25 mm (by putting a block of 25 mm thickness) from its initial position.	Brake cylinder pressure 3.8 ± 0.1kg/cm ²	
13	Hand Brake		
13.1	Apply hand brakes(by one person only and strike all wheels with hammer)	There should not be ringing sound	
14.	APM arm movement from fully retracted position to bogie side frame top.	96 +1/-0 mm	
15.	Brake cylinder pressure with unrestricted movement of lever arm of APM Device.	Brake cylinder pressure 2.2± 0.25 kg/sq.cm.	
16.	Restrict the movement of lever arm of APM Device with 17 mm block. placed on bogie frame	Brake cylinder pressure 3.8 ± 0.1kg/cm ²	
17	Restrict the movement of lever arm of APM Device with 15 mm block. placed on bogie frame	Brake cylinder pressure 2.2± 0.25 kg/sq.cm	

18.	AR Charging time (Pressure rise from 0 to 5.0 kg/sq.cm.)	175 ± 30 Sec for C3W D.V	
		60 to 120 Sec for KEO D.V	
19.	CR Charging time (Pressure rise from 0 to 4.8 kg/sq.cm.)	165 ± 20 Sec for C3W D.V	
		160 to 210 Sec for KEO D.V	

* However, if in a few cases, the piston stroke at empty pressure during testing on SWTR exceeds the specified range, the piston stroke is to be tested by locking the wheels with wedges.

S.No. 18 and 19 to be checked at the time of prototype Wagon only

Works Inspector		RDSO Inspector	
Signature:		Signature:	
Name:		Name:	
Designation:		Designation:	