

ELEVATION

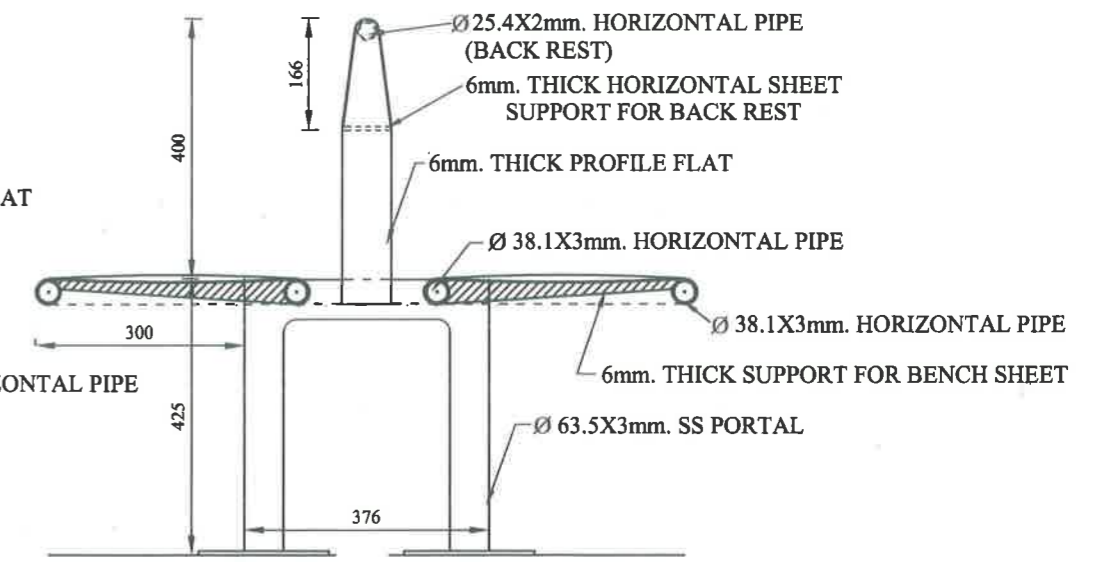

SIDE ELEVATIONAL SECTION AT A-A

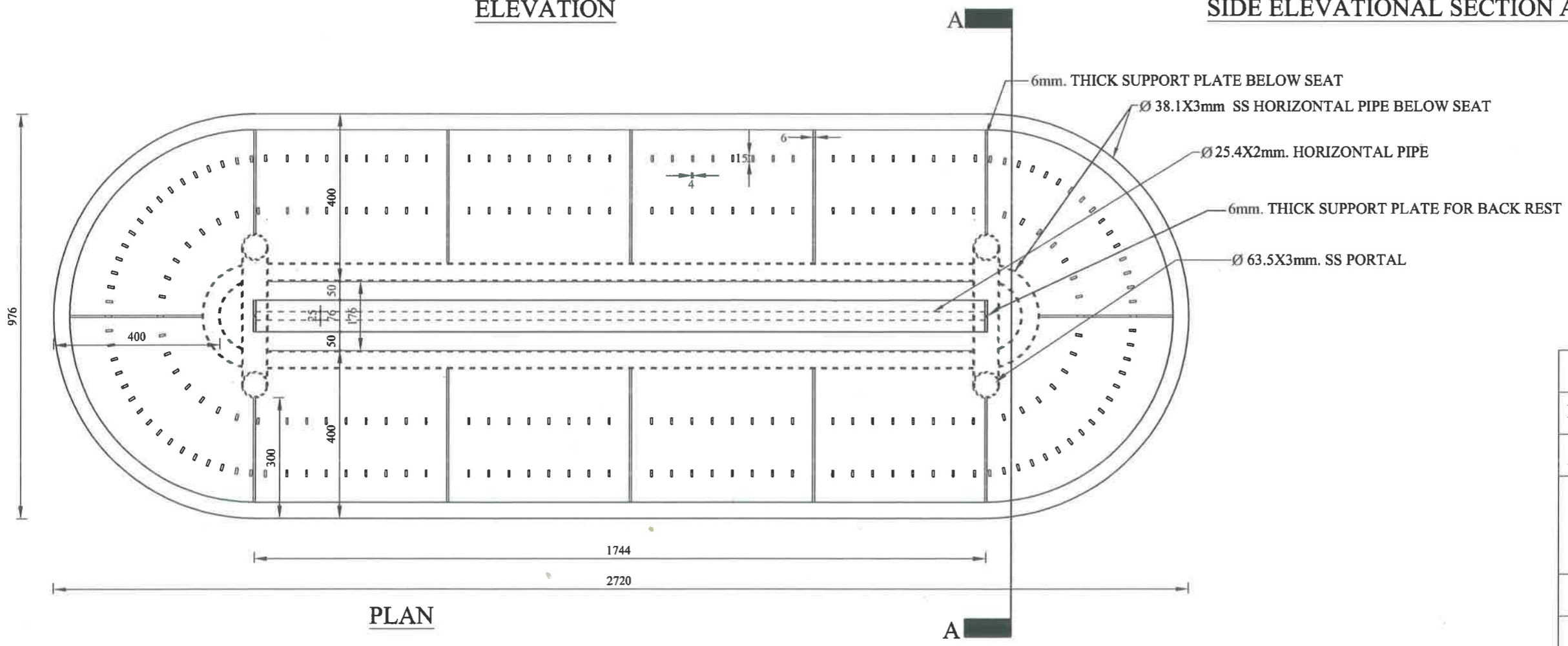

PLAN

ED/WORKS	<i>[Signature]</i> 05/06/18
DIR/WORKS	<i>[Signature]</i> 05-06-18
ADE/WORKS	<i>[Signature]</i>
TEN SEATER BENCH WITH BACKREST WITH SEAT PARTITION	
SCALE: NTS	DATE : 05.06.2018
DRAWING NO. RDSO/WKS/2018/4	

- All dimension are in millimeter
- Stainless steel shall confirm to grade 304/316 IS:6911/ASTM A240/A240M
- Argan welding shall be done by T I G .arc welding ,as per IS:9604
- All fabrication work shall be done on roller machine by C N C laser cutting and argon welding.
- Minimum weight of each bench will not be less than 95.0 Kg.
- Welder should be certified for safety. efficiency & quality as per EN 287-1.

<i>[Signature]</i>			
DRAWN BY	ALT:	DESCRIPTION	DATE

WORKS DIRECTORATE
 R. D. S. O. LUCKNOW.