

PLAN

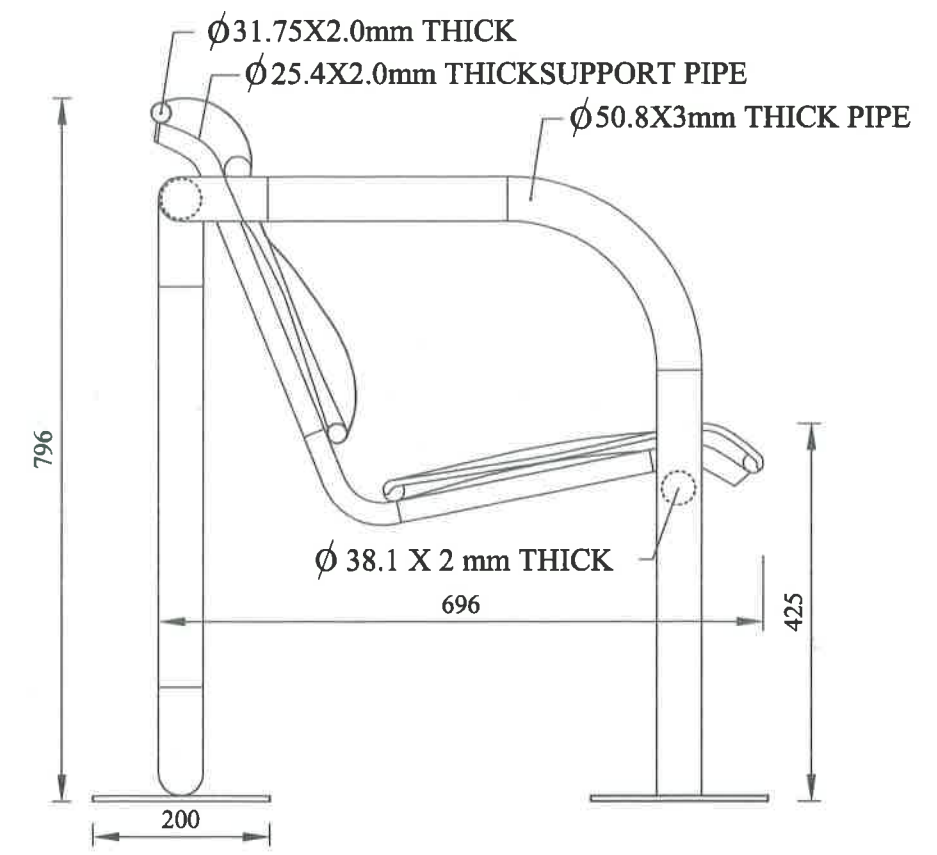

SIDE ELEVATION

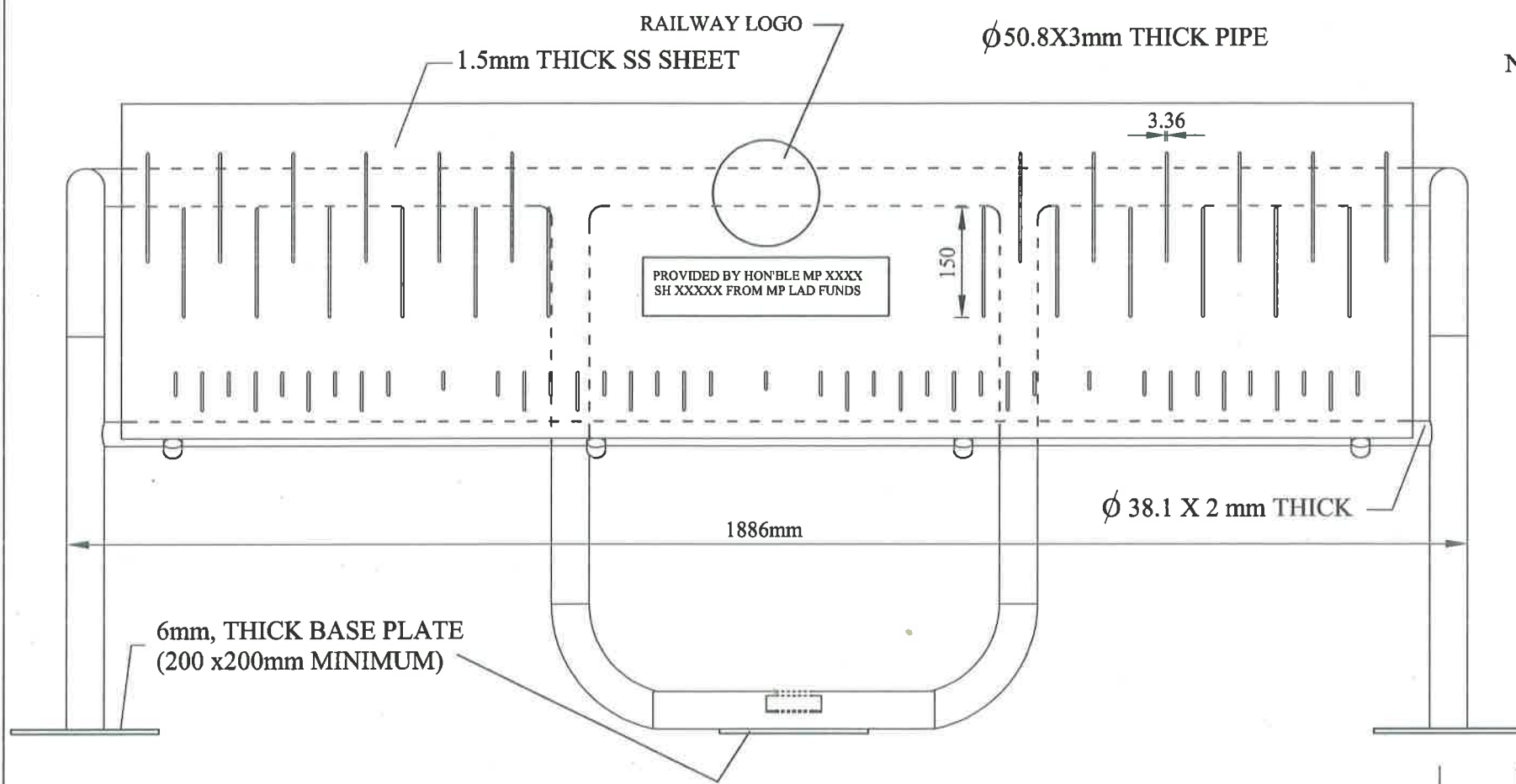

ELEVATION

NOTE:-

1. ALL DIMENSIONS ARE IN MILLIMETRES.
2. STAINLESS STEEL SHALL CONFIRM TO GRADE 304/316 IS:6911/ASTM A240/A240M
3. ARGON WELDING SHALL BE DONE BY TIG,ARC WELDING AS PER IS:9604
4. ALL FABRICATION WORK SHALL BE DONE ON ROLLER MACHINE BY CNC LASER CUTTING AND ARGON WELDING.
5. MINIMUM WEIGHT OF EACH BENCH WILL NOT BE LESS THAN 68.0 KG.
6. WELDER SHOULD BE CERTIFIED FOR SAFETY, EFFICIENCY & QUALITY AS PER EN 287-1

ED/WORKS	<i>Set 05/06/18</i>
DIR/WORKS	<i>05.06.18</i>
ADE/WORKS	<i>(Signature)</i>
4 SEATER BENCH WITH BACKREST, WITHOUT SEAT PARTITION	
SCALE :- NTS	DATE :- 05.06.2018
DRAWING No. RDSO/WKS/2018/3	
WORKS DIRECTORATE RDSO LUCKNOW	

<i>(Signature)</i>	ALT:	DISCRIPTION	DATE
DRAWN BY			