

Issued by: Joint Director, ED, RDSO	ENGINEERING DESIGN PERFORMANCE SPECIFICATION	No: TS/ED/2014/01
Approved by: Executive Director, ED, RDSO	Engine Development Directorate Research Designs and Standards Organisation, Manak Nagar, Lucknow	First issued: Oct-2014 Supersedes: TS/ED/2013/73 and TS/ED/2013/74
Subject	Engine Control Unit (ECU) with associated accessories and Interfacing device to interface the Engine Control Unit (ECU) of the Electronic Fuel Injection System with Microprocessor Based Control System (MBCS) of the ALCo locomotives	
Affects Models	DLW built 16 cylinder 3100/3300/3600 hpALCo locomotives	
Ref. Drawings		
Originator		
Supplier	The following information is the property of Engine Development Directorate of Research Designs and Standards Organisation, Manak Nagar, Lucknow and must be treated as privileged communication between suppliers and Indian Railways	
Related specifications	No. TS/ED/2013/71 of June 2013	

ENGINE CONTROL UNIT

1. INTRODUCTION

Engine Control Unit (ECU) is an electronic device, used to control the start of injection and duration of injection of Electronic Fuel Injection (EFI) pump as per speed and load condition of the engine. ECU generates analog and digital signals which are used to indicate the engine's operating states but can also serve other purposes and functions. Communication with other units is established via a serial interface and CAN bus protocols.

Through a second CAN interface the system communicates with other control systems as well as with diagnostics and monitoring systems. The combination of electronic regulation, governing and monitoring provided by the above components permits to create an engine management system which allows further optimization of the system as a whole.

2. FUNCTIONAL REQUIREMENTS OF THE ECU

2.1 Variable Injection Timing

ECU should be capable to run the engine on notch-wise variable injection timing as programmed in the map.

2.2 Start Quantity Adjustment

For setting start quantity, minimum start quantity or maximum start quantity may alternatively be selected. Furthermore variable start quantity should be provided, by which start quantity is automatically increased during start-up.

2.3 Speed Ramps

According to the requirement speed ramps may be programmed for increasing or decreasing the speed. In addition, a separate speed ramp may be provided for start-up which may make the engine ramp slowly to operating speed after starting.

- 2.4 Variable Set point Adjustment**
The set point can be adjusted analogously by voltage or by current. By means of digital switch inputs, it is possible to change over to fixed speed or to digital synchronizing with speed increase/decrease or to 4-bit control for 16 velocity stages. Change over between the different set point adjustments is possible.
- 2.5 Correction of PID Parameters**
To optimize the dynamics of every operating point, the PID parameters may be corrected independently of speed, temperature and load by means of freely programmable stability maps.
- 2.6 Speed Dependent Quantity Limitation**
It should be possible to program quantity limitation curves in dependence of speed so that for all speeds there can be torque reduction as is admissible for the engine or desired by the user.
- 2.7 Cylinder Equalization by means of Exhaust Gas Temperature**
Equalization of cylinder output should be implemented by means of exhaust gas temperature. Exhaust gas temperature is here used as an indicator for cylinder power. Equalization of cylinder temperature aims at equalizing power output of the cylinder. To this purpose exhaust gas temperature of each cylinder should be reported to the ECU. ECU can calculate the average value of the cylinder temperature and correct it by increasing the fuel quantity of the particular cylinder, if found less than the average value.
- 2.8 Boost Pressure Dependent Quantity Limitation**
In the locomotive engine, fueling should be reduced to achieve smokeless operation whenever there is low boost pressure in respect to engine notch. The respective limit curves can be programmed accordingly.
- 2.9 Temperature Dependent Idling Speed and Quantity Limitation**
At low temperature, the engine can be run at some higher idling speed. With the engine warming up, idling speed is reduced to its normal value. It should be possible to program quantity limitation curves in dependence of temperature so that for every temperature there will be torque reduction available as is admissible for the engine or desired by the user.
- 2.10 Map Controlled Start of Injection**
Start of injection and duration of injection can be programmed by means of characteristic maps. In addition, there is a tuning option on a per cylinder basis. Thereby, optimization of fuel consumption and emission level of the engine is possible.
- 2.11 Oil Pressure Monitoring**
For the purpose of oil pressure monitoring, speed/pressure dependent limit curves should be provided. If oil pressure is low, an alarm is issued, if oil pressure continues to drop, the engine should be shut down.
- 2.12 Sensor Monitoring**
If a sensor is faulty, an alarm should be issued and there will be a changeover to emergency operation or an engine shutdown.
- 2.13 Load Regulation System**
A load regulation system should be provided, by which generator output is regulated in dependence on speed and load.
- 2.14 Configuration of Input and Output Signals**
The inputs and outputs should be configured within a wide range according to the requirement.
- 2.15 Click Test**
On first commissioning of the engine, the cabling of the solenoid valves can be checked for

correctness by a click test.

2.16 Data Logging/ Error Recorder

At the time of error occurred in the system, data related to cause of error should be recorded in the ECU. This data can be downloaded as and when required.

2.17 Control Solenoid of Electronic Fuel Injection Pump

ECU should be able to control the solenoids of the EFI Pumps having solenoids with the following characteristics-

S. No.	Parameter	Nominal value
1.	Operating voltage	24 V DC
2.	Voltage range	16-33 V DC
3.	Pull in voltage	5.56 V DC
4.	Pull in current	16-18 Amp
5.	Pull in duration	< 1100 μ s
6.	Boost current	12A
7.	Hold current	5-10 A
8.	Hold in duration	10 ms
9.	Free air Inductance	0.410 \pm 0.06 mH
10.	Winding wire	0.643 mm (Bare wire)
11.	Fly time	0.8 mS
12.	Working temperature range	-40 to 125 $^{\circ}$ C
13.	Protection grade	IP 66K

3. DESIGN SPECIFICATIONS

3.1 Engine Control Unit (ECU)

Engine Control Unit (ECU) of the EFI system shall take over all the functions of the existing governor of the locomotive. Supplied ECU and associated accessories will be fitted with EFI pumps 16mm or more plunger dia. Technical details, inputs/outputs of the ECU are given below-

S.No.	Parameters	Details
1.	Operating Voltage	24 V DC
2.	Minimum Voltage	18 V DC
3.	Maximum Voltage	33 V DC
4.	Residual ripple	Max. 10% with 100 Hz
5.	Output Voltage for solenoids	24 V DC
6.	Current consumption	Max. 0.5A per cylinder and max. 24 A for 2ms
7.	Storage Temperature	-55 to 105 $^{\circ}$ C
8.	Ambient Temperature	-40 to 80 $^{\circ}$ C
9.	Air Humidity	Up to 98% at 55 $^{\circ}$ C
10.	Contamination	Resistant against substances typically present in the engine environment
11.	Vibration	Max. 9g with 64-2000 Hz

12.	Shock	50 g, 11 ms, Half Sine Wave
13.	Protection Grade	IP-65
14.	Isolation resistance	>1 MOhm with 48V DC

3.1.1 Inputs and Outputs

All inputs and outputs are reverse polarity proof and short circuit proof against battery positive and battery negative. Inputs and outputs of ECU is given below-

S.No.	Parameters	details
Input Signals		
1.	2 speed sensor inputs	Hall sensors with 25-8000 Hz
2.	3 Temperature Inputs (Lube oil Temperature, Fuel Oil Temperature and Coolant Temperature)	PT 1000/PT-100
3.	16 High Temp. Inputs for Cylinder Head Temperature	'K' Type Thermocouple
4.	3 Pressure Inputs (Boost Pressure, Oil Pressure and Fuel Oil Pressure)	Pressure Sensors (0-10 bar)
5.	4 bit Notch Signals (digital)	0-72 V
Output Signals		
6.	16 Solenoid Valves drives	I<6A, I<25A for time < 2ms, 24V DC Pulse Width Modulation
7.	LCP signal	24-68 V

3.1.2 Communication Port

One Serial Port communication is required to connect the PC/Laptop for parameterization and control of the ECU. Communication port should be as per international standard (ISO 9141/SAE J1587 RS 485 upto 9600 baud rate).

3.2 Dc-Dc Convertor

Power supply available in the locomotive battery bank is 72 V DC and the input supply requirement of the ECU is 24 V DC, therefore a DC-DC convertor is required to step down the power supply to suit the ECU inputs.

Dc-Dc converter box will perform the following functions:

- Convert the 72 V DC supply from the locomotive to the 24 V DC supply required for the on-board circuits. The ECU circuits work on 24 V DC supply.
- Digital output/ relay cards for sending out the status signals of the ECU as external signals. These signals are Governor ready, Cylinder fault alarm, General alarm etc.
- Digital Input cards for isolating the engine notch signals from the interface box before sending to the ECU. Engine notch signals are generated by the driver and transmitted by the MBCS to the interface box. Error reset signals to the ECU are also sent through the digital input cards.

Analog output card for excitation control of the Traction Alternator. This signal is taken by the interface box, processed and given to the MBCS.

3.3 Connection Cables

Connection cables should be high temperature resistant up to 800 °C for cylinder temperature sensors and up to 300 °C for other cables. Cables should be covered with Teflon or other suitable high temperature resistant covering material. Necessary coupler, shields, clamps should be provided with the cables. Details of the cables are given below:-

S.No.	Description of cables	Approx. length of cables**	Qty. required for one loco set
1.	Cable from ECU to left and right bank of EFI pumps	14 meter	02 no.
2.	Cables for all sensors (a) ECU to Speed and position sensor (b) ECU to Lube Oil Pressure Sensor (c) ECU to Coolant Temp. Sensor (d) ECU to Boost Air Pressure Sensor (e) ECU to 16 no. Cylinder Temperature Sensors	10 meter 2 meter 18 meter 10 meter 14 meter	01 set.
3.	Cable from ECU to DC-DC convertor	2 meter	01 no.
4.	Cable from interfacing box to loco terminal board	6 meter	01 no.
5.	Cable from DC-DC convertor to interfacing box	2 meter	01 no.
6.	Cable from ECU to USB drive of PC/Laptop	4 meter	01 no.

**** These lengths will vary according to the wiring harness layout (Refer Annexure 1 of Fitment Instructions (TS/ED/2013/75)).**

3.4 Sensors

The following type of sensors will be used in the EFI system to monitor the various parameters, details of the sensors are given below-

3.4.1 Speed and Cam Position Sensor (Hall Sensor)

Speed and position sensor (hall sensor) will be used to measure the engine rpm and to monitor the correct position of camshaft. According to this input of the hall sensor, ECU can calculate the start of injection and duration of injection and send the signal to the EFI pumps. Two numbers of hall sensors for each loco set will be required for reliability purpose. The details of the sensor are given below-

S.No.	Parameter	Specified
1.	Length of sensor including coupler	110 mm
2.	Length of threaded portion	76 mm
3.	Type of thread	M 18 X 1

4.	Switching frequency	1 Hz-16000 Hz
5.	Air gap	0.5 mm – 2 mm
6.	Supply Voltage	8 – 33 V
7.	Output	Push-pull
8.	Signal shape	Square-Wave
9.	Pull up	1 K Ohms
10.	Operation temperature range	-40 ⁰ C to 125 ⁰ C
11.	Protection	IP 65
12.	Vibration	<10g (10Hz-100Hz)
13.	Shock	<50 g

3.4.2 Boost Air Pressure Sensor

Boost Air Pressure (BAP) sensor is required to monitor the boost air pressure of the engine. The details of the sensor are as under-

S.No.	Parameter	Specified
1.	Measuring Range	0-5 bar
2.	Over pressure	10 bar
3.	Supply Voltage	9-32 V DC
4.	Output Signal	4- 20 mA
5.	Operation temperature range	-40 ⁰ C to 125 ⁰ C
6.	Protection	IP 65
7.	Vibration	<15g (20 -2000Hz)
8.	Shock	<50g

3.4.3 Lube Oil Pressure Sensor

Lube oil pressure is used to monitor the lube oil pressure of the engine. The details of the sensor are given below-

S.No.	Parameter	Specified
1.	Measuring Range	0-10 bar
2.	Supply Voltage	9-32 V DC
3.	Output Signal	4- 20 mA
4.	Operation temperature range	-40 ⁰ C to 125 ⁰ C
5.	Protection	IP 65
6.	Vibration	<15g (20 -2000Hz)
7.	Shock	<50 g

3.4.4 Coolant Temperature Sensor

Coolant temperature sensor is required to monitor the coolant temperature of the engine. The details of the sensor are as under-

S.No.	Parameter	Specified
1.	Measuring Range	-50 °C to 150 °C
2.	Supply Voltage	9-32 V DC
3.	Output Signal	4- 20 mA
4.	Protection	IP 65
5.	Vibration	<20 g (10 -300Hz)
6.	Shock	<50 g

3.4.5 Exhaust Gas Temperature Sensor

Sixteen exhaust gas temperature sensors are fitted in the cylinder heat exhaust ports. These are used to measure average cylinder head temperatures.

S.No.	Parameter	Specified
1.	Length of sensor	100mm
2.	Dia. Of sensor	8 mm
3.	Length of threaded portion	22 mm
4.	Type of threads	Tapered (diameter 20.8 mm to 20.3 mm), 1.5mm pitch
5.	Measuring Range	0-800 °C
6.	Protection	IP 65
7.	Vibration	<60g (10 -100Hz)
8.	Shock	<50g for 11ms Half Sine

INTERFACING DEVICE

In the Electronic Fuel Injection(EFI) system all the features of existing governor of the locomotive will be performed by Engine Control Unit (ECU). Interfacing device is to be used to interface the Engine Control Unit of the EFI system with the Microprocessor Based Control System (MBCS) of the locomotive.

4. FUNCTIONAL REQUIREMENTS OF INTERFACING DEVICE

The main function of the interfacing device is to interface the Engine Control Unit (ECU) to the Microprocessor Based Control System (MBCS) of the locomotive. Engine notch signal in the form of four bit binary signal (through four wires) from the MBCS through locomotive

5. DEVELOPMENT OF INTERFACING DEVICE

Interfacing device has to be developed in two phases. In the first phase interfacing of the ECU of the EFI to the Engine Test Bed controller in Engine Development Directorate is to be done. Only after successful development of interfacing device for Engine Test Bed controller in Engine Development Directorate, interfacing device for fitment on the locomotive is to be developed. Block diagram for interfacing of the EFI ECU to the Engine Test Bed controller in Engine Development Directorate is shown below:

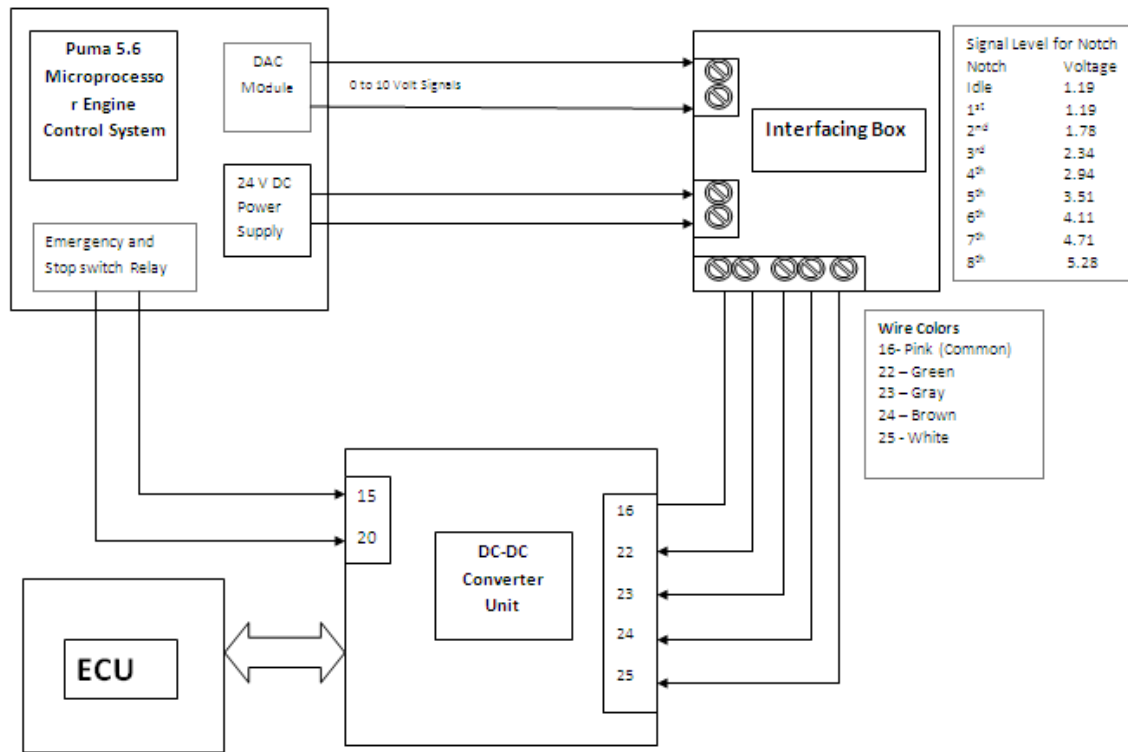

Figure: Block Diagram of Interfacing Box to PUMA 5.6

Here the reference speed analog signals in the form of voltage signals are generated by the DAC (Digital Analog Converter) module of Test Commander. Engine notch-wise voltages are shown in the figure above. These signals are fed to the interface box, where the signals are processed and converted by the Comparator and Encoded into the form of Digital Binary signal. These binary signals are then given to the freewheeling diodes, which drive the relays to generate the Notch signal to the DC-DC Converter and from there to the ECU of EFI system. The 'STOP' and 'EMERGENCY' switch signals are directly fed to the DC-DC Converter unit, by which the engine can be stopped by the Test Commander. With this interface, it is possible to control the speed of the engine at specific engine notches. It is not possible to continuously vary the speed of the engine from the Engine Test Controller (PUMA). For continuous variation of speed of the engine, DC-Desk 2000 software of EFI ECU has to be used on the ECU side. For continuous variation of speed of engine from PUMA directly, an analog reference speed signal from PUMA to the DC-DC Converter box will be required.

6. DESIGN SPECIFICATIONS OF INTERFACING DEVICE

S.No.	Parameters	Details
1.	Operating Voltage	0-72 V DC
2.	Storage Temperature	-55 to 105 °C
3.	Ambient Temperature	-40 to 80 °C
4.	Air Humidity	Up to 98% at 55 °C
5.	Contamination	Resistant against substances typically present in the engine environment
6.	Vibration	Maximum 9 g with 64-2000 Hz
7.	Shock	50 g for 11 ms, Half Sine Wave
8.	Protection Grade	IP-65
9.	Isolation resistance	>1 MOhm with 48 V DC

6.1 Inputs:

- (i) Four notch signals (0-72 V) from MBCS
- (ii) LCP signal (4 to 20 mA) from ECU

6.2 Outputs:

- (i) LCP signal (24-68V) to locomotive terminal board

6.3 Block Diagram of Interfacing between Microprocessor Based Control System of Locomotive and EFI ECU is shown below.

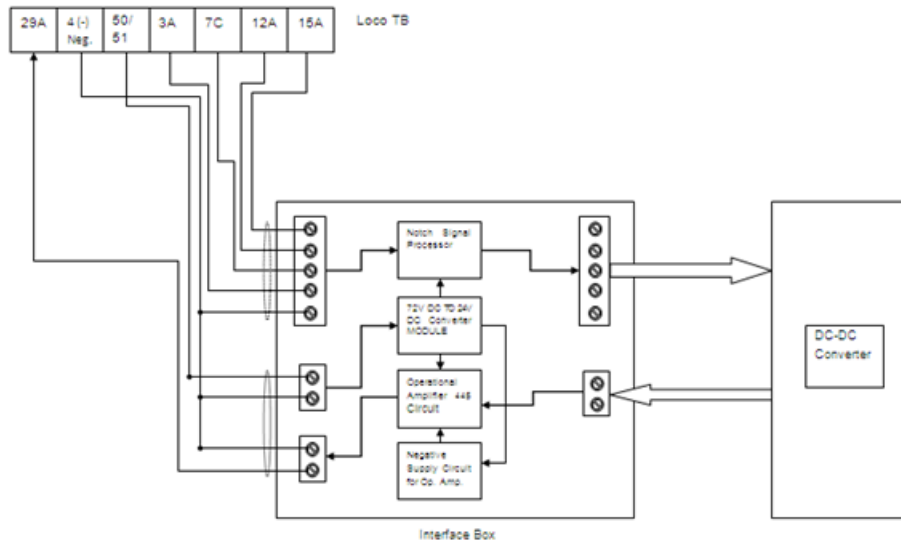

Figure: Block Diagram of Interfacing Box between MBCS and EFI ECU

7. GENERAL OPERATING CONDITION

ECU and Interfacing device is to be fitted in the nose compartment or any other suitable location of the locomotive. Interfacing device is to be designed for the temperature range of 0 to 105 °C.

8. EXPECTED PERFORMANCE

Maximum acceptable failure rate in two years, including all failure modes is 0.25% after successful completion of the Reliability Verification Testing of the complete EFI system.

9. RELIABILITY DEVELOPMENT OF THE EFI SYSTEM

- a. In case of first supply of the ECU and the Interfacing system, the same have to be first qualified for performance testing on the Engine Test Bed in Engine Development Directorate at RDSO. For this purpose the Interfacing system for interfacing the ECU of the EFI to the Engine Test Bed Controller has to be developed and successfully proven. During the engine validation tests on the Engine Test beds at RDSO, the supplier will ensure maximum 500 hour or ½ year warranty from commencing of tests or one year warranty from the date of manufacture of the system.
- b. After successful completion of the basic validation testing on the Engine Test Beds in the Engine Development Directorate at RDSO, next 10 sets will be tested on Diesel locomotives for Reliability Verification Testing (RVT). This test will be for a duration of one year on a population of 10 EFI fitted diesel locomotives. During this period, all the failure modes experienced during the operation of the diesel locomotives will be documented and the supplier will carry out the necessary trouble shooting jointly with Indian Railways (RDSO and the Diesel sheds). The supplier will carry out the necessary design/ manufacturing modifications and introduce modified components on the locomotives so as to ensure that the Reliability of the EFI system is enhanced. At the end of the one year period it is understood that all possible failure modes will be identified and corrective and preventive action introduced by the supplier (for Design and Manufacturing issued) and Indian Railways (RDSO and Diesel Sheds for the Maintenance issues). During the RVT period the supplier will ensure maximum 2000 hours of operation from the date of start of tests or 24 months from the date of manufacture of the EFI system.
- c. Supply beyond the 10th EFI system will incorporate all modifications as implemented during the Reliability Verification Testing (RVT). Supply beyond the 10th EFI system will be construed as Series supply and standard stores warranty of Indian Railways shall be applicable.

10. PRODUCTION INSPECTION FOR QUALITY ASSURANCE

The method of inspection and sample size shall be arrived at by mutual negotiations between the supplier and Indian Railways's quality control department and vendor quality assurance committee. All test procedures called out on any applicable Engineering Test Instructions must be followed. The manufacturer to indicate applicable engineering test instructions for their equipment.