

## TRACTION INSTALLATION DIRECTORATE

कर्षण संस्थापन निदेशालय



सत्यमेव जयते

GOVERNMENT OF  
INDIA MINISTRY OF  
RAILWAYS

भारत सरकार, रेल मंत्रालय

TECHNICAL SPECIFICATION FOR  
CONTROL AND RELAY PANEL FOR 25 kV ac TSS INCLUDING  
SPECIFICATION  
FOR  
NUMERICAL TYPE PROTECTION RELAYS FOR TRACTION  
TRANSFORMER, 25 KV SHUNT CAPACITOR BANK AND  
TRANSMISSION LINE FOR 25 kV ac TSS  
ON INDIAN RAILWAYS

Specification No. TI/SPC/PSI/PROTCT/6072

विशिष्ट संख्या: टी•आई• / स्पेक / पी•एस•आई• / प्रोटेक्ट / 6072

Revised in: .....

ISSUED BY

TRACTION INSTALLATION DIRECTORATE,  
RESEARCH DESIGNS AND STANDARDS ORGANISATION,  
LUCKNOW – 226011

SPECIFICATION NO. <b>TI/SPC/PSI/PROTCT/6072</b>	Effective from: .....	Page 2 of 51
--	--------------------------	--------------

SPECIFICATION: technical specification for control and relay panel for 25 kV ac TSS including specification for numerical type protection relays for traction transformer, 25 kV shunt capacitor bank and transmission line for 25 kV ac TSS on Indian railways

SPECIFICATION No. **TI/SPC/PSI/PROTCT/6071 (Rev.1)**

Amendment Number	Amendment /Revision	Total pages including drawings	Date of Issue
0	NA	58	12.07.2012
1	Rev.1	52	Feb-2015
2	A&C Slip No.1	53	24.10.16

SPECIFICATION No. **TI/SPC/PSI/PROTCT/6072**

	PREPARED BY	CHECKED BY	APPROVED BY
SIGNATURES			
DATE			
DESIGNATION	SSE/PR	DTI-3	PED/TI

SPECIFICATION NO. TI/SPC/PSI/PROTCT/6072	Effective from: .....	Page 3 of 51
---	--------------------------	--------------

## INDEX

CL A U S E N O	H E A D I N G
1.0	S C O P E
2.0	TRACTION POWER SUPPLY SYSTEM
3.0	SERVICE CONDITIONS
4.0	GOVERNING SPECIFICATIONS
5.0	DESIGN FEATURE OF CONTROL AND RELAY PANEL
6.0	PROTECTIVE RELAYS
7.0	SCHEME OF PROTECTION
8 . 0	PARTICULARS OF POTENTIAL AND CURRENT TRANSFORMERS
9 . 0	TESTS
10.0	TECHNICAL DATA LITERATURE AND DRAWINGS
1 1 . 0	ERECTION TESTING AND COMMISSIONING
12.0	OPERATION, MAINTENANCE INSTRUCTIONS
13.0	SPARES AND SPECIAL TOOLS
14.0	PACKAGING & FORWARDING

## ANNEXURE

Annexure-A	LIST OF ABBREVIATIONS
Annexure-B	DEFINITIONS & EXPLANATIONS
Annexure-C	SCHEDULE OF GUARANTEED PARTICULARS
Annexure-D	LIST OF THE EQUIPMENT ON PANEL
Annexure-E	GENERAL SCHEME OF TRACTION POWER SUPPLY SYSTEM
Annexure-F	TYPICAL SCHEMATIC DIAGRAM OF PROTECTION FOR DOUBLE TRANSFORMER TRACTION SUB-STATION
Annexure-G	TYPICAL SCHEMATIC DIAGRAM OF PROTECTION FOR SINGLE TRANSFORMER TRACTION SUB-STATION

SPECIFICATION NO. TI/SPC/PSI/PROTCT/6072	Effective from: .....	Page 4 of 51
---	--------------------------	--------------

## 1.0 SCOPE

1.1 This specification applies to the design, manufacture, supply and erection & commissioning of control and relay panel complete with RDSO approved numerical **communicable** type protective relays for control, monitoring and protection in the traction substations comprising of 220/132/110/66 kV and 25 kV circuit breakers, 25 kV interrupters and 220 or 132 or 110 or 66/27 kV single phase transformers, substation equipment, 25 kV over head equipment (OHE) feeders and shunt capacitor banks & transmission lines (if asked for by the purchaser in the tender).

1.2 The control & relay panels have been classified into three categories for the purpose of this specification, viz.

TYPE-I: Required at 220/27kV or 132/27 kV or 110/27kV or 66/27kV step down substations.

TYPE-II: Required at 220/27kV or 132/27kV or 110/27 kV or 66/27kV step down substations with an additional respective 220kV/132 kV/110 kV/66 kV line sectioning facilities.

TYPE-III: Required at 220/132/110/66 kV switching station with only line sectioning facilities.

1.3 The control & relay panels offered shall be complete with Numerical relays for different protection functions, meters, auxiliary relays, control switches, indicating LEDs, annunciator, wiring and all other accessories and materials necessary for efficient control and protection of substation equipments and feeders. Such accessories and materials shall be deemed to be within the scope of this specification whether specifically mentioned or not.

1.4 In 31<sup>st</sup> MSG, it was decided to provide testing jack facility in the Control & Relay Panel. It is to be developed in a such way that when testing kit is connected to the testing jack, relay connections will get disconnected from main circuit automatically and connected to testing circuit. After testing and removal of testing kit from jack, relays will get reconnected to main circuit automatically.

1.5 Feeder protection relays shall be governed by their respective RDSO specifications as mentioned in clause no. 6.1. Transformer, 25 kV shunt capacitor bank & transmission line protection will be governed by this specification.

1.6 This specification generally refers to double line sections having two feeder CB's and two traction transformers provided at the sub stations (as per the lay out drawings enclosed at Annexure-E) however in case of the more number of lines and/or additional transformers at sub stations, the purchaser shall furnish the layout drawings for the traction system. The quantity of the panels, relays and all equipments shall be as per the new drawings; however, the design aspects of each protection relays and individual panel equipment shall be same as per this specification.

The design drawings of the panel's physical layout, mimic diagrams etc. shall be approved by purchaser in advance under such condition.

1.7 Generally substations shall be provided with two traction transformers, however if only one transformer is being installed initially (with a provision for installation of another transformer at a later date) then under this arrangement, two panels shall be supplied and the panel for the other transformer shall also be equipped with all fittings, components, annunciation etc. complete with wiring as provided on the panels for double transformer substation, except for the protective and auxiliary relays. Necessary cut outs for housing these relays at a later date shall be provided, which shall be blanked with suitable plates of MS sheets secured from inside of the panel for the sealing purpose. Purchaser shall clearly specify

SPECIFICATION NO. <b>TI/SPC/PSI/PROTCT/6072</b>	Effective from: .....	Page 5 of 51
--	--------------------------	--------------

its requirements in the tender document in this regard.

1.8 Parallel operation of 2 nos 21.6 MVA traction transformers at a TSS shall be permitted under exceptional circumstances and protection scheme shall have to be adopted as per RDSO instruction no. TI/IN/0017(July/2008). The purchaser shall advise its requirements at the time of tendering.

1.9 This specification supersedes specification No. ~~TI/SPC/PSI/PROTCT/6070 (9/08) with A&C Slip No.1 and TI/SPC/PSI/PROTCT/6071(2/15), Rev.1 with A&C Slip No.1.~~

1.10 The “Make in India” Policy of Government of India shall be applicable.

## 2.0 TRACTION POWER SUPPLY SYSTEM

### 2.1 GENERAL SCHEME OF TRACTION POWER SUPPLY SYSTEM

2.1.1 Power is received from the grid network of the supply authorities at 220 kV/132 kV/110 kV/66 kV, at traction substations (TSS). 25kV power supply for traction is drawn through a single-phase step-down traction transformer. The primary winding of this transformer is connected to any two phases of the incoming three phase lines and on the secondary side, either of the two terminals of the 25 kV winding is connected to the traction overhead equipment (OHE), while the other is solidly earthed and connected to the running traction rails.

2.1.2 Each transformer has its associated circuit breakers on the primary and secondary sides, with a separate set of 25 kV circuit breakers called “Feeder Circuit Breakers” for feeding the traction OHE lines.

2.1.3 Adjacent TSS are fed from different phases of the three-phase system in rotation. Neutral sections in front of sectioning and paralleling post (SP) are provided in the 25 kV OHE for segregating the different phases. **The Automatic Phase Switching Section (APSS) may also replace Neutral Section and purchaser shall specify regarding the provision of the same as per the specification no. TI/SPC/PSI/0190, in the tender specification.** In between the TSS and SP, sub-sectioning and paralleling posts (SSP) are provided for paralleling the UP and DN line OHE and also for sectionalizing and fault localization. The attached drawing No. ETI/PSI/702-1 at Annexure-E shows the general scheme for traction power supply system.

2.1.4 The supply to the OHE can be switched ON/OFF through interrupters which do not open automatically on fault, but can be closed on to a fault. The fault is cleared by the feeder circuit breaker provided at the traction substation.

2.1.5 Normally power supply from a TSS extends upto the SP on either side of the substation, but in case of an emergency necessitating total shut down of the substation, power supply from adjacent TSS on either side of the failed substation can be extended upto the failed substation by closing the bridging interrupters at the two SPs. Also, under certain emergency conditions the power supply can be extended beyond the failed TSS up to the next SP through feeder CB’s of adjoining TSS.

2.1.6 If any other different traction supply arrangement is adopted due to special requirements (e.g. more than two transformer bays, parallel operation of transformers at TSS etc.) then same shall be advised by the purchaser.

### 2.2 NATURE OF TRACTION LOAD AND FAULTS ON THE OHE SYSTEM

2.2.1 The traction load is a frequently and rapidly varying one between no load and overload. The TSS equipment are subject to number of earth faults/short circuits. The

magnitude of fault current may generally vary between 40% and 100% of the dead short-circuit value. However, at times the fault current may be much less e.g. in case of bird faults, arcing faults or bond open earth faults etc. which shall fall under the category of high impedance earth faults. The details of the protection relays & scheme are given in Para 7.1 to 7.4.

2.2.2 The AC electric rolling stock is fitted, for conversion of ac to dc, with single-phase bridge-connected silicon rectifiers with smoothing reactor for feeding the dc traction motors. The rectifiers introduce harmonic currents in the

25 kV Power supply. On few locomotives there are controlled asymmetrical thyristor bridge and GTO Pulse width modulation devices, in place of silicon rectifiers. Typical percentages of harmonics present in the traction current with electric rolling stock are as follows:

#### Harmonic Generated by IR Locomotives

Sl. No	Harmonic No.	With Diode Rectifier	With Thyristor	With GTO's
1.	3 <sup>rd</sup> harmonic (150 Hz)	15%	23%	3%
2.	5 <sup>th</sup> harmonic (250 Hz)	6%	14%	2%
3.	7 <sup>th</sup> harmonic (350 Hz)	4%	10%	0.5%
4.	9 <sup>th</sup> harmonic (450 Hz)	-	4%	0.35%
5.	11 <sup>th</sup> harmonic (550 Hz)	-	3%	0.4%
6.	THD's	16.64%	29.15%	3.68%

2.2.3 The average power factor of the conventional electric locomotive and electric multiple units generally vary between 0.7 and 0.8 lagging without compensation.

2.2.4 In big yards and loco sheds, a large number of locomotives stand idle with only the load of their auxiliaries, drawing fairly large reactive power. The load power factor is therefore, rather low.

2.2.5 Three Phase electrical locomotives and EMU'S have been introduced in Indian Railways. These types of locomotives and EMU'S are capable of regeneration during braking. **The train sets have also been introduced with multiple driving coaches each having pantograph for collection of current from OHE. These trains sets are also capable of injecting high regenerative current in to OHE.**

### 2.3 SHORT CIRCUIT APPARENT POWER OF THE SYSTEM

The short- circuit apparent power for various system voltages is as under, however the actual values shall be furnished by purchaser in consultation with supply authority:

#### Short Circuit Level

Highest system voltage KV	Short circuit apparent power MVA
52	200
72.5	3500
123	6000
145	10000
245	20000

### 2.4 AUXILIARY POWER SUPPLIES AT TRACTION SUBSTATION

SPECIFICATION NO. <b>TI/SPC/PSI/PROTCT/6072</b>	Effective from: .....	Page 7 of 51
--	--------------------------	--------------

The following power supplies are available at a traction substation.

- i.) 110 V (+15% & - 30%) dc.
- ii) 240V +/- 20% ac, 50Hz +/- 3%, single phase from a 25/0.24 kV auxiliary transformer.

## 2.5 BOOSTER TRANSFORMERS (BTs)

In order to reduce inductive interference in adjacent telecommunication circuits on certain sections of electrified track, booster transformers are installed in series with the 25 kV traction overhead equipment (OHE). The primary winding of the booster transformer is connected to the 25 kV overhead equipment (OHE) and the secondary winding is in series with the return conductor (RC) which is strung close to the 25 kV overhead equipment. Booster transformers with a rating of 150 or 100 kVA provide necessary voltage to force the traction return current from the rail and earth to flow through the return conductor. The Booster transformers have a leakage impedance of about 0.15 ohm each and are spaced about 2.66 km apart.

## 2.6 OHE IMPEDANCE

For the purpose of relay setting calculations, the values of loop impedance with earth return for the OHE (65mm<sup>2</sup> catenary and 107 mm<sup>2</sup> contact wire) are taken as under:

OHE impedance value for normal 25 kV AC OHE (65mm<sup>2</sup> catenary and 107 mm<sup>2</sup> contact wire)

Sl. No.	OHE configuration	Impedance
1.	One OHE without BT and RC	0.41 □ 70 □ Ohms/km
2.	Two OHEs without BT and RC	0.24 □ 70 □ Ohms/km
3.	One OHE with BT and RC	0.70 □ 70 □ Ohms/km
4.	Two OHEs with BT and RC	0.43 □ 70 □ Ohms/km

Booster transformer impedance of 0.15 per booster transformer is added where these are provided.

## 2.7 TRACTION TRANSFORMER

Normally 21.6 (ONAN)/30.24 (ONAF) MVA or 30 (ONAN)/42 (ONAF) MVA, 220 or 132 or 110 or 66/27 kV, single-phase with maximum of (12.5+/-0.5) % impedance rating of traction transformer is provided at TSS. The traction transformers are designed to carry short time overloads as the traction loads may exceed for short periods.

Rating of the power transformer:

Rated capacity for	Rated secondary current of the Transformer	
	30 MVA	21.6 MVA
Continuous	1111 Amps	800 Amps
15 Min	150% i.e 1666.5 Amps	150% i.e 1200 Amps
5 Min	200% i.e. 2222 Amps	200% i.e. 1600 Amps
Ability to withstand short circuit	Thermal : 5 second Dynamic : 0.25 second	Thermal : 5 second Dynamic : 0.5 second

Note: The rating and design of the traction transformer may change hence manufacturer/supplier of the C&R panels must confirm the ratings and configuration from the

SPECIFICATION NO. <b>TI/SPC/PSI/PROTCT/6072</b>	Effective from: .....	Page 8 of 51
--	--------------------------	--------------

purchaser.

### 3.0 SERVICE CONDITIONS

3.1 The control and relay panels are intended for use in humid tropical climate in any part of India with the following atmospheric conditions:

1.	Max. ambient temperature	70 <sup>0</sup> C
2.	Min. ambient temperature	-25 <sup>0</sup> C
3.	Max. Temp attainable by an object exposed to Sun	70 <sup>0</sup> C
4.	Max. & Minimum relative humidity	100% & 22%
5.	Max. (Basic) wind pressure	200 kg/m <sup>2</sup>
6.	Elevation above the mean sea level	2000m (As per IEC 60255-1)
7.	Vibrations	Max: 350 microns Average: 30 – 150 microns Time duration: rapidly varying time duration 15 – 70 ms.

3.2 The control and relay panels shall be installed in masonry control cubicles at the traction substations, which are normally unattended. The masonry control cubicles are situated close to the Railway tracks and hence the Panels are subjected to vibrations due to running trains.

### 4.0 GOVERNING SPECIFICATIONS

The main components covered by the specification shall conform to the following standard specifications (latest version), which shall be applied in the manner altered, amended or supplemented by the specification and Indian Electricity Rules where applicable.

Sl. No.	IS/IEC	Description
1.	IS 3231	Electrical relays for power system protection
2.	IS:8686	Static protective relays
3.	IS:1248	Direct acting indicating analogue electrical measuring instruments.
4.	IS:8130	Conductors for insulated electrical cables and flexible cords
5.	IS:2705	Current transformers
6.	IS:3156,BS:3938	Voltage transformers
7.	IS: 694	Control cable
8.	IS: 9224	HRC cartridge fuse
9.	IS: 6875	Control switch/ Push button
10.	IS: 5578/11353	Marking and identification of conductors and apparatus terminals
11.	IEC 60947	Low voltage switchgear and control gear
12.	IS: 12083 I & II	Specification for Electrical relays, Contact performance & Insulation tests
13.	IEC 60898-2	Circuit breakers for ac and dc operation
14.	IEC 60255-1 (Part-I)	Measuring relays and protection equipment - Part 1: Common requirements
15.	<b>IEC 60255-121:2014</b>	Electrical relays - Impedance measuring relays



SPECIFICATION NO. <b>TI/SPC/PSI/PROTCT/6072</b>	Effective from: .....	Page 9 of 51
--	--------------------------	--------------

16.	IEC 60255-12	Electrical relays - Directional relays and power relays with two input energizing quantities
17.	<b>IEC 60255-27</b>	Insulation coordination for measuring relays and protection equipment - Requirements and tests
18.	IEC 60255-21-1	Vibration test on measuring relays and protection equipment
19.	IEC 60255-21-2	Shock and bump tests on measuring relays and protection equipment
20.	IEC 60255-21-3	seismic tests on measuring relays and protection equipment
21.	IEC 60068-2	Environmental tests.
22.	IEC 60255-27	Product safety requirement
<del>23.</del>	<del>IEC 60255-26</del>	<del>Electromagnetic compatibility requirement</del>
24.	IEC 60529	Degrees of protection provided by enclosures (IP code)
25.	IEC 61810-2	Reliability.

All other components such as indication LEDs, terminal blocks, annunciator windows, MCBs, bell etc. shall conform to relevant IS specifications (latest version) and such specifications shall be duly mentioned by the tenderers in their offer.

Other related and linked specifications which should be read in conjunction with this specification are as under.

TI/SPC/PSI/PTs/0992	220/132/110/66/25 KV PTs
ETI/PSI/90 (6/95) with A&C 1&2	25 KV current transformer
ETI/PSI/117 (7/88) with A&C 1&6	220/132/110/66 KV current transformer
TI/SPC/PSI/LVCBIN/0120	25 kV single pole, double pole, pole mounted, outdoor vacuum circuit breaker (VCB) and vacuum interrupter (BM) for Indian Railway
ETI/PSI/118(10/93)with A&C 1 to 8	21.6 MVA, 220,132,110,66KV/25KV single phase, 50Hz traction power transformer for Railway AC traction substations.
TI/SPC/PSI/30TRN/2070(10/2007)	30 MVA 220/27, 132/27, 110/27 kV and 66/27 kV single phase traction transformer ONAN/ONAF with on load tap changer.
ETI/PSI/120(2/91)	Code of practice of earthing
TI/SPC/PSI/PROTCT/2983(8/2001) or latest	Technical specification for panto flash over protection relay for 25 kv system
TI/SPC/PSI/PROTCT/1982(12/2003) with A&C slip No.1 or latest	Technical specification for delta-I type high resistive fault selective relay for 25 kv system
TI/SPC/PSI/PROTCT/5070(Rev.1) or latest	Microprocessor based numerical feeder protection module comprising DPR, WPC, PTFE, Inst. OCR and auto reclosure relays

## 5.0 DESIGN FEATURES OF CONTROL & RELAY PANEL

## 5.1 CONSTRUCTIONAL FEATURES

5.1.1 The panel shall be vertical, self- supporting, closed type steel construction. It shall be developed in such a way that optimum utilization of space on front, rear and side panels is made and all-important hardware is on the front side panel.

The panel shall be accessed from rear or side of panels and for this, hinged type doors with locking arrangement shall be provided. Lifting hooks shall also be provided on the panel for loading of panel for transportation.

Any other construction of the panels may also be suggested by the panel manufacturers to RDSO, which may be considered based on the merits like savings, size, maintainability etc. of the proposed design.

5.1.2 The control and relay panel shall have modular construction to facilitate ease of expansion and replacement. The instruments, control switches, annunciation window, main protection relays, meters, mimic and indicating lamps shall preferably be mounted on front side of the control panels. Equipment like balance protection relays, auxiliary relays, indications, alarm acknowledgement push button & control switches for transformer tap changer, blower fan indication, push button for DC fail & DC low/high alarm accept and test etc. shall be provided on side or rear panels. Bell / hooter, ICTs, terminal blocks, etc. may be mounted at suitable place inside the panel.

5.1.3 According to clause 1.4, the Testing Jack/ Test Switch shall be available in the Control & Relay Panel. The relay shall take care of the “Testing Jack” provided in the Control & Relay Panel for testing the relay with the help of testing kit connected through Testing Jack without removing the relay from the panel and without disconnecting the connection of CT, PT etc. manually. The communication port shall be available in testing jack for connecting the relay test kit. The relay should be compatible with the testing jack / Test Switch provided in the panel. This aspect should be considered in designing the relay back panel so that all the available necessary interfaces are meeting the requirement of Testing Jack without compromising the safety while testing through latest Relay Test Kit.

5.1.4 The design shall be keeping in view the ease of maintenance. The distribution and layout of the equipment on the panels shall be arranged by the successful tenderer with the approval of the purchaser, so as to achieve a systematic and neat appearance. The manufacturer shall submit drawings of dimension details, circuits, terminals details, design and layout of equipment on the panels to RDSO for approval prior to manufacturing of prototype. All future panels shall be manufactured as per the RDSO approved drawing and designs and shall be verified by the purchaser.

5.1.5 The panel shall be fabricated from sheet steel of thickness not less than 3.0 mm for front, rear, doors and base panels, and not less than 2.0 mm for side, roof and door panels.

5.1.5 The bottom portion of the panel shall be provided with detachable type sheet steel covers (over trench portion) with suitable cable glands to facilitate entries of control cable from trenches to control panel. The panel shall be suitable for erection flush with the concrete floor by evenly spaced grouting bolts projecting through the base channels of its frame. The panel shall be made in suitable sections to facilitate easy transport, handling and assembly at site.

5.1.6 Ribbed type rubber matting to ensure personnel safety of operating staff shall be provided on the floor in the front and back outside of the panel. Mat shall be continuous length, black color, minimum 1/4-inch thick, minimum three foot (3') wide and shall extend

SPECIFICATION NO. TI/SPC/PSI/PROTCT/6072	Effective from: .....	Page 11 of 51
---	--------------------------	---------------

the full length of entire panel.

5.1.7 The size of C & R panel shall be approved by RDSO at the time of design drawings approval of first prototype. The size of panel shall vary depending up on the number of transformer and switching equipments at TSS. The control and relay panels for 25 kv shunt capacitor bank and transmission line protection shall be separate. The purchaser shall indicate its requirement in the tender clearly.

5.1.8 The C&R panel shall conform to IP 52 class to avoid ingress of vermin, insects, rats and dust and suitable for use in tropical humid climate.

5.1.9 All control and supply cables will be laid in a distribution trench running under the control panel. The cables will enter the board from the trench through suitable glands. The supplier will furnish detailed dimensions of the trench work required. Provision shall be made to seal the points of entry of cables to prevent access of insects and lizards into the board.

5.1.10 The sheet steel as well as other steel works shall be properly treated and then an under coat suitable to serve as base and binder for the finishing coat shall be applied. The exterior and base frame of the panel shall be coated with industrially accepted Siemens gray shade and interior surfaces of the panels shall be epoxy powder coated of white color followed by a 200-degree bake ovening. The finish shall be virtually scratchproof with all metal surfaces coated to a uniform thickness on the powder coat line.

5.1.11 To avoid rusting of the panels during service, the following pre-treatment through seven-tank process shall be ensured prior to painting:

- ❖ Degreasing
- ❖ Rinsing (Water wash)
- ❖ Pickling (Acid pickling)
- ❖ Rinsing (Water wash)
- ❖ Zinc Phosphating
- ❖ Rinsing (Water wash)
- ❖ Drying
- ❖ Powder coating & curing

If any painted surface gets damaged during transit, the surface finish shall be restored at site after erection by tenderer.

5.1.12 There shall be provision for power down mode for the system when the substation is not being manned. In this case all the protection elements shall function as usual but the alarm, annunciation/display and local acknowledgement features will remain out of circuit till the system is activated again. A separate front accessible ON/OFF switch shall be provided for this purpose.

5.1.13 All the protection modules, dc and ac supplies, equipment in switch yard/traction sub-station, annunciation windows and other peripheral equipment, measuring instruments required for the control panel shall be hard wired to form a control and relay panel. For all the external connections there shall be terminal blocks for terminating the connections.

5.1.14 A local/remote change-over switch shall be provided for each remote controlled apparatus viz. circuit breaker/interrupter for changing over the control from local to remote and vice versa. The tripping initiated by the protective relays shall however trip the circuit breakers directly irrespective of the position of the changeover switch.

5.1.15 Each CB/interrupter shall be controlled by 3 position (trip- neutral - close) control switches having spring return to neutral feature and pistol grip handle along with 2 NO contacts each for trip & close commands.

SPECIFICATION NO. <b>TI/SPC/PSI/PROTCT/6072</b>	Effective from: .....	Page 12 of 51
--	--------------------------	---------------

5.1.16 An indicative list of the equipment to be provided on the control panels is at Annexure-D. Any additional equipment needed for satisfactorily working and adequate protection for TSS equipment which is not covered in annexure-D shall also to be provided.

## 5.2 TERMINATION FOR THE PURPOSE OF INTERFACING OF C& R PANEL WITH SCADA

The successful tenderer shall provide necessary wiring and terminal blocks in control and relay panel for inter connection with the SCADA RTU as mentioned below.

### 5.2.1 TELECOMMANDS FROM RCC

The traction sub- stations shall be un-attended type and the control of all circuit breakers, interrupters, off load tap changers, lock out release of CB's, Panto flash over relay enable/disable, time synchronization of relays and motor operated isolators (if any), shall be normally done from Remote control Center (RCC) through the SCADA system (to be provided by the purchaser under a separate contract). The operation of the controlled equipment shall only be possible when the associated local/remote selector switch on the control and relay panel is kept in "Remote" mode.

For this purpose, the successful tenderer shall provide necessary wiring in the C & R panel including from each local/remote selector switch of the CB/BM's to the terminal blocks for interconnecting to RTU. The purchaser shall indicate any additional requirement of telecommands wiring in its tender document.

### 5.2.2 TELE-SIGNALLING OF INFORMATION

The following information shall generally be tele-signaled to the RCC for monitoring the status of switchgears and various other events/alarms from TSS.

#### 5.2.2.1 STATUS INDICATIONS OF SWITCHGEARS

- i) ON/OFF status of circuit breakers, interrupters, and motor operated isolators (if any).
- ii) Low gas/air pressure alarm and lock out condition of the circuit breakers to remote control center.

SF-6/vacuum circuit breakers are provided at the traction substations. Necessary contacts in the control circuits of the circuit breaker mechanism shall be available for signaling of the alarm and locked out conditions. The contact multiplication functions of the same shall be inbuilt in the concerned numerical relays or through auxiliary relays.

#### 5.2.2.2 TELE SIGNALLING OF TRANSFORMER FAULTS/ALARMS

##### i) TRANSFORMER-1&2 ALARM

On traction transformers buchholz relay, winding temperature indicator, oil temperature indicator and low oil level indicator alarm contacts are provided. The multiplication of these contacts will be inbuilt in the numerical protection relays or by using auxiliary relays. For this purpose, available contacts shall be wired up and terminated at terminal block of C&R panel for interconnection with RTU. In addition to above tele signaling of the status of transformer blower fan working shall also be required.

##### ii) TRANSFORMER-1&2 FAULT

The tripping command for both HV & LV transformer CBs through inter trip relay by any of the protective relays i.e. differential, earth leakage, over current on primary side, buchholz, excessive winding temperature, excessive oil temperature, PRD trip etc. necessary contacts shall be wired and terminated on separate terminal block for interconnection with RTU.

- iii) The status of DSS (directional selector switch) and HIS (hand interlocking switch) shall

be made available at C & R panel, for this purpose necessary contacts shall be wired up and terminated on terminal block for interconnection with RTU.

iv) The traction transformers at the substation shall be fitted with motor operated off-circuit or on load tap changer with its associated 110 V dc control circuit. The wiring for control of tap changer and indication of tap position shall be terminated on a terminal block in the control panel for interconnection with the RTU.

#### 5.2.2.3 SUPERVISION OF 110 V D.C SUPPLY OF VARIOUS CONTROL CIRCUITS

(i) Healthiness of 110 V dc supplies of various circuits is explained at clause No. 5.6. The successful tenderer shall wire necessary contacts of each dc supervision relay up to the terminal blocks for inter-connection with the RTU.

(ii) 110 V dc supply fail to the trip circuits of 220/132/110/66 kV transmission line breakers for all the circuits installed (applicable to type II & III control panels only) shall also be wired and terminated up to the terminal boards for interconnection with RTU.

#### 5.2.2.4 PT FUSE FAILURE

The fuses on the secondary side of the following PT<sub>s</sub> are to be supervised independently.

i) 25 kV/110V PT for feeder-1

ii) 25 kV/110V PT for feeder-2

iii)  $\frac{220 \text{ kV}}{\sqrt{3}}$  /  $\frac{110 \text{ V}}{\sqrt{3}}$  or  $\frac{132 \text{ kV}}{\sqrt{3}}$  /  $\frac{110 \text{ V}}{\sqrt{3}}$  or  $\frac{110 \text{ kV}}{\sqrt{3}}$  /  $\frac{110 \text{ V}}{\sqrt{3}}$

or  $\frac{66 \text{ kV}}{\sqrt{3}}$  /  $\frac{110 \text{ V}}{\sqrt{3}}$  (as the case may be) PT<sub>s</sub> of the transmission lines

For items (i) & (ii) above, the PT fuse failure is part of the feeder protection module. For the purpose of interconnections to RTU, the successful tenderer shall provide necessary wiring up to terminal blocks in the control and relay panel.

#### 5.2.2.5 PROTECTION RELAYS OPERATION

The operation of distance protection relays, instantaneous over current relays, wrong phase coupling relays, PT fuse failure relays, Delta-I relays, Panto flash over, master trip, inter trip relay etc. for 25 kV individual feeders and relay healthy, auto reclose, lockout are also required to be telesignalled to RCC.

In addition to above the numerical protection relays provided in the panel shall have number of other telesignals available (details of which shall be available in the relay catalogues/design particulars). The successful tenderer shall wire all such contacts of each numerical relay and terminate on separate terminal blocks, for inter-connection with RTU for future use.

Further there shall be provision of 3 nos. spare auxiliary relays individually having 2 NO + 2 NC contacts along with the necessary wiring in the panel for future use of any additional telesignals/contact multiplication.

#### 5.2.2.6 TELESIGNALLING OF CIRCUIT BREAKER TRIP CIRCUIT FAILURE

Healthiness of trip circuits and coils of different circuit breakers shall be monitored by concerned numerical protection relay. The failure of trip circuit shall be telesignalled to RCC. For this purpose, the successful tenderer shall provide necessary wiring and terminate it on terminal block for inter-connection with RTU.

#### 5.2.2.7 TELESIGNAL OF LOW AND HIGH 110 VOLT DC CONTROL VOLTAGE

Contacts for telesignalling of low/high dc control voltage monitoring relay as per clause No. 5.7 shall be wired up and terminated on the terminal block for inter-connection with RTU.

SPECIFICATION NO. <b>TI/SPC/PSI/PROTCT/6072</b>	Effective from: .....	Page 14 of 51
--	--------------------------	---------------

### 5.2.2.8 TELESIGNALLING OF THE HEALTHINESS OF OHE AND INCOMING SUPPLY

Healthiness of the OHE voltage and incoming voltage shall be monitored through indication type PT's, for this purpose suitable terminals and wiring shall be provided in the panel for interconnection with SCADA.

### 5.2.3 TELEMETERING OF CURRENT, VOLTAGE, AND POWER FACTOR TO RCC

The SCADA system has been designed to telemeter analog parameters to RCC, necessary wiring in the panel up to the terminal blocks shall be provided by the successful tenderer for following parameters.

- a) Two current parameters of the 25 kV feeders through transducers /suitable IED's taking reference from the 25 kV, 1000-500/5 A or 1500- 750/5A or 3000-1500/5 CT.
- b) One voltage parameter from either of the 25 kV/110 V feeder PT<sub>s</sub> through a suitable change over arrangement and a voltage transducer/suitable IED's.

Note: The current coils of current and power factor transducers are to be connected in series with the coils of ICT provided for metering in panel. The successful tenderer shall provide suitable terminal blocks inside the control and relay panel such that it is possible to connect the transducer coils in series with the coils of ICT used for metering by suitable rearrangement of links on the terminal block.

### 5.3 MIMIC DIAGRAM

5.3.1 The scheme of connections at the traction sub-station (including feeding post ) showing the circuit breakers, transformers, isolators and interrupters shall be represented by a single line mimic diagram on the control panel. The color of the bus bar (mimic) shall be signal red to shade 537 of IS:5 for 220/132/110/66 kV, golden yellow to shade 356 of IS:5 for 25 kV and black for 240V. The mimic diagram shall be made of aluminum strip or reflector PVC strip and fixed on the panel. The width of the mimic shall be of 8mm. The successful tenderer will be required to submit his proposal for layout of equipment on the control panel to the purchaser for his approval.

5.3.2 Automatic semaphore LED type indication shall be incorporated in the mimic diagram to indicate the ON/OFF position of circuit breakers and interrupters.

5.3.3 The position of 220/132/110/66 kV and 25 kV isolators shall be represented on the mimic diagram by manually operated semaphore switches.

### 5.4 INDICATING INSTRUMENTS

5.4.1 Scalable 4 digits bright red LED display digital Ammeters, Voltmeters and power factor meters shall be provided as indicated in Annexure- D. The instruments shall be of the switchboard type, back connected, suitable for semi- flush or flush panel mounting, provided with dust tight cases of IP 54 class.

5.4.2 The instruments shall generally conform to IS 13875 part 1-3 and shall have typical accuracy of 99.5% at full scale and resolution of 1% to 100% of full scale. The traction load current and voltage waveforms are not true sinusoidal hence the digital type meters should also have capability to measure the true RMS value of voltage and current waveforms (up to the crest factor of 3.0) distorted due to presence of harmonics.

5.4.3 Digital type smart energy meter with accuracy class 0.2S or better shall be provided for two incomers. The meter shall be installed at HV side. The energy meter shall be configurable CT & PT primary and secondary values. The energy meter shall have

suitable backlit LCD display, which able to display at least four parameters at the same time. The energy meter shall conform to IS:14697, IEC:62053-22, IEC:62053-23, IEC:62053-31, IEC:61010. The minimum requirements of energy smart energy meter are:

- 1 no. RS485 port to communicate with RTU over MODBUS protocol.
- Voltage
- Current
- MW
- MVAR
- MVA
- MWH
- MVARH
- PF
- Frequency
- Energy Import
- Energy Export
- MD

5.4.4 The digital meters shall be fully configurable for use along with different type/class and ratios of CT/PT in use on various TSS of IR. All the digital meters shall be suitable for working on 110-volt dc or 180-240-volt single-phase AC supply and under tropical condition of high temperatures up to 60 degree Celsius and relative humidity of 95%. Suitable voltage and current surge protection shall be in built for the digital meters provided on the panel.

5.4.5 Power factor meter shall have range of lagging 0.5 to leading 0.5 in suitable span, with accuracy +/- 1%. The power factor meter should be capable of measurement of power factor for non-sinusoidal waveforms generated by traction loads by using the suitable techniques to average the instantaneous power then divide it by multiplication of true RMS voltage and current.

5.4.6 All technical details of digital meter like sampling frequency, response time and band width etc. regarding capability of the meter to measure true RMS values shall be furnished by the tenderer along with the operating, safety, installation and commissioning and maintenance instructions of equipment manufacturer.

5.4.7 All circuits including the input modules of instruments shall be capable of withstanding at least 20% overload for 8 hours and 20 times for 3 second. The instruments shall be capable to withstand a high voltage test of 2,000V rms to earth for one minute.

5.4.8 The ammeter & current circuit of power factor meter shall be connected in series of CT through suitable rating of inter posing transformer (ICT).

## 5.5 ANNUNCIATION

5.5.1 Red LEDs and bell, both operating on 110 V d.c. supply, shall be provided on the control panel for giving individual visual and audible alarm whenever any of the protective relays operates. The visual alarm shall be of flasher type, which shall continuously flicker till acknowledged, after which it shall only glow. The annunciation LEDs shall be provided on the control panel at the top in suitable number of rows for concerned transformer/circuit-breaker/PT etc. The alarm accepting, visual resetting and annunciation testing buttons shall be mounted on the control panel at a convenient place & height. The alarm bell shall be mounted inside the control board.

5.5.2 The tenderer shall clearly specify in his offer detailed technical description of the

annunciation clearly bringing out the type of annunciator being provided by him with detailed technical description of the annunciator.

5.5.3 Annunciation shall be arranged for the following fault conditions as applicable for each circuit. There shall be 20 % spare windows available at the annunciator window to cater for future provisions.

a) TYPE I & TYPE II CONTROL PANEL

- 1) 220/132/110/66 KV, HV and LV transformer breaker auto-trip.
- 2) 25 kV transformer breaker auto trip.
- 3) 25 kV feeder breaker auto-trip.
- 4) Transformer Buchholz trip.
- 5) Transformer oil temperature trip.
- 6) Transformer winding temperature trip.
- 7) Transformer pressure relief device trip.
- 8) Transformer Buchholz alarm.
- 9) Transformer oil temperature alarm.
- 10) Transformer winding temperature alarm.
- 11) Transformer low oil level alarm.
- 12) 25 kV bus supply / PT (type-II) fuse fail.
- 13) 240 V, single-phase supply fails (only one No.).
- 14) 220/132/110/66 kV line breaker auto trip (Applicable only for Type II).
- 15) 220/132/110/66 kV line PT fuse fail (Applicable only for Type II).
- 16) Auto-reclosure locks out.
- 17) Low air / gas pressure alarm (separate window for HV, LV and Feeder CB).
- 18) Low air /gas pressure trip and lock (separate window for HV, LV and Feeder CB).
- 19) Panto flashover relay bypassed.
- 20) OHE supply fail / indication type PT (type-I) fuse blown (Individual window for each indication type PT/feeder).

b) TYPE III PANEL

- 1) 220/132/110/66 kV line breaker auto trip.
- 2) 220/132/110/66 kV line PT fuse fail.

5.5.4 For annunciation of OHE supply fail or indication PT (TYPE-I) fuse blown, suitable relay operated through each indication PT shall be provided in the C&R panel. The burden of the relay on the PT shall not exceed 2VA. The relay shall be of continuous duty type and should not get affected on transient fluctuations in voltage.

5.5.5 For annunciation of 240 V, single-phase ac auxiliary supply failure, tenderer may use suitable relay operated on the 240 V ac or use advanced type annunciation with built in feature to monitor the same. Tenderer may clearly specify this in his offer.

5.6 DC SUPPLY SUPERVISION AND ALARM

Provision shall be made for alarm and supervision of 110 V dc supply to various control, alarm and indication circuits. 110 V dc supply to control and relay panel is made available from 110V battery charger/batteries through distribution panel provided in the control room, to generally feed following separate circuits:

- 1) Control circuit for H.V breaker of traction transformer
- 2) Control circuit for L.V. breaker of traction transformer
- 3) Control circuit for 25 kV feeder breakers.
- 4) Control circuit for interrupters



5) A common circuit for alarm and indication purposes.

Necessary provision for supervision of dc supply to each of the above circuits shall be made by using supervision relays. On failure of dc supply to any circuit, an LED (provided individually for each of the circuits) and alarm, both operated on 240 V, single-phase AC supply, shall come up. A push button, in series with each supervision circuit, shall be provided by the side of the corresponding dc fail indication LED in order to test the healthiness of the supervision and alarm circuit. In addition, a common miniature type push button for the cancellation of horn shall also be provided.

5.7 Low and High control voltage (110V DC) and 240V a.c. Alarm / Trip 5.7.1

Aux. DC Under voltage relay:

- (i) Two stage of definite time under voltage relay with independently settable of voltage and operating time to monitor the d.c. auxiliary under voltage for each panel shall be provided.
- (ii) Stage 1 is used for pre-trip alarm and stage 2 for trip the circuit breakers. The setting range for under voltage in the range of 40 V to 110V in steps of 1V and operating time for trip element in range of 200ms to 10000ms in the steps of 50ms and for pre-trip alarm in range of 1 sec to 300sec in steps of 5sec.

5.7.2 Aux. DC Over voltage relay:

- (i) Single stage of definite time over voltage relay for alarm shall be provided to monitor the d.c. auxiliary over voltage for each panel.
- (ii) The voltage shall be settable in the range of 120 V to 170V in steps of 1V and operating time 1 sec to 300sec in steps of 5sec.

5.7.3 The relay shall also monitor the 240 V auxiliary a.c. voltage (from battery charger input voltage). When voltage measured less than set under voltage or more than set over voltage an alarm contact shall be available separately for each.

The under voltage shall be settable in the range of 150V to 200V and over voltage 240V to 300V in steps of 5V. The operating time shall be separately settable in the range of 1 sec to 300sec in steps of 5sec.

5.7.4 The relays shall be designed for continuous service (auxiliary supply) voltage of 110V+50% /-70% dc supply or 240V+30%/-30%, 50Hz, 1Phase a.c. supply whichever available. Both ac & dc supply should be connected to relay and priority of normal working shall be on dc supply and in case of failure of dc supply, the relay shall be worked on ac supply.

Frequent lightning and switching surges may come in ac supply voltage. Manufacturer shall ensure fail safe design of power supply module for such quality of power.

5.7.5 The relays should have facility to record at least 50 cycles or 1 sec (40 ~~45~~ prior to and 10 ~~5~~ after fault sensing or 800 ms prior to 200 ms after sensing abnormal auxiliary dc voltage) of d.c. waveforms for under voltage trip and over voltage alarm. At a time at least 100 ~~200~~ such waveforms for voltage shall be storable and shall be retrievable through ~~RS-232 serial communication~~ **USB** port (or any other superior type of COM port) through a Laptop computer.

5.7.6 Suitable software shall be supplied along with the relays to download and interpret the fault waveform and other data stored in the relays. The software shall be capable of analyzing the peak and average values of dc voltage. The accuracy of measurements shall be 1ms for time, 1V for voltages. The software shall also be capable of communicating with the relay and

SPECIFICATION NO. <b>TI/SPC/PSI/PROTCT/6072</b>	Effective from: .....	Page 18 of 51
--	--------------------------	---------------

viewing and altering of settings.

5.7.7 The relays shall be capable to show live d.c. & a.c. voltage parameters on the LCD display. Manufacturer shall clearly indicate/furnish the sampling rate, accuracy and range of above measurements at the time of design & development to RDSO. It shall also be capable to display the numerical values of the latest 150 events (i.e. dc low alarm & trip, dc high alarm & ac low & high alarm) with date and time stamping in serial order on the LCD display.

5.7.8 Three numbers of output trip contact for dc under and over voltage trip shall be provided on the relay to trip the HV, LV & Feeder CBs simultaneously. The alarm and telesignaling contact for each element shall be separately available on the relay.

#### 5.8 TRIP CIRCUIT AND COIL CONTINUITY SUPERVISION

The numerical relays associated with breakers shall have facility to monitor the continuity and the availability of dc supply to the trip circuit of each circuit breaker, necessary indication and alarm of this shall be made available on the panel by a LED and annunciation. If this facility is not available in a numerical relay then this feature shall be made available by using an auxiliary relay and the current taken by this relay shall not exceed 10 mA. In series of trip circuit supervision, a push button shall be provided on the panel to check the trip circuit supervision functioning.

#### 5.9 INDICATION LEDs

5.9.1 Low consumption, extra bright LED indicating lamps of approximately 20 mm diameter with insulated housing having group of good quality LEDs inside, suitable for panel use shall be provided. The LEDs shall be suitably wired to glow at 110 V dc supply.

5.9.2 The following color scheme shall be adopted for indication LEDs.

Indication for	Colour LEDs
Circuit breaker/interrupter closed (ON)	Red
Circuit breaker/interrupter open (OFF)	Green
* Trip circuit of CB <sub>s</sub> Unhealthy	Yellow
* 110 Vdc fail supervision.	Amber
*DC under / over voltage	Yellow
Line potential connected to 25 kV PT type-I (indication type)	Red
Blower fan working.	Blue
HV incoming supply healthy indication (for each phase)	Red
Transformer tap changer position	White

\* These LED<sub>s</sub> shall normally remain extinguished and shall light up on 230V, 1 ph AC on the occurrence of an alarm or while manually testing the healthiness.

5.9.3 The followings indications shall be provided on C & R Panel with alarm, which shall work on 230 V single phase AC.

- 1) DC supply fail (separate indication for each circuit)
- 2) Trip circuit unhealthy (separate indication for each CB)
- 3) DC under/over voltage.

#### 5.10 TERMINAL BLOCKS FOR WIRING AND TESTING PURPOSE

5.10.1 Terminal blocks for testing purpose shall be mounted conveniently inside the control

SPECIFICATION NO. TI/SPC/PSI/PROTCT/6072	Effective from: .....	Page 19 of 51
---	--------------------------	---------------

panel so as to be easily accessible. The current rating of the contact shall be 10 A continuous and 150 A for at least one second at 240 V ac. or dc.

5.10.2 The current testing terminals shall be provided with short circuiting links or other suitable devices

(a) To short circuit the current transformer leads before interrupting the normal circuit for injection from external source for testing (applicable for secondary injection tests of relays).

(b) To complete the current transformer circuit through a testing instrument in which case the testing instrument shall be connected to the current terminals and the intermediate link opened out (applicable for checking indicating instruments with sub-standard meters at site).

5.10.3 The potential testing terminals shall preferably be housed in narrow recesses of the moulded insulation block to prevent accidental short circuits.

5.10.4 The arrangement of the terminals shall be made such that either portable type electronic energy and maximum demand meters, or trivector meters and power/harmonic analyzers etc. for recording kW, kVA, KVAR and harmonic distortion etc. can be connected when required.

5.10.5 Vertical or horizontal pillar stack type terminal blocks, 1100 V class and not less than 30 A rating shall be provided for terminating outgoing ends of control panel wiring and the corresponding incoming tail ends of the control cables. Provision shall be made on each pillar for holding 20% extra connections. The terminal blocks shall have individual identification markings, which shall be either engraved or made indelible by any other means. Pillars of terminal blocks meant for connections of incoming control and indication cables shall be specially provided with identification labels indicating function(s) of each terminal block.

5.10.6 The terminals shall be of stud type suitable for terminating the ends of control wiring and outgoing cable ends through crimped terminal spade/lugs, which shall be securely tightened with nuts and spring washers. Suitable shrouds of unbreakable transparent material shall also be provided on each terminal block.

5.10.7 Terminal blocks connected to potential and current circuits shall not be placed adjacent to each other in a pillar. Where such segregation is not convenient due to any reason, a dummy spacer of insulating material of adequate thickness or a space terminal block shall be provided in between two such circuits. All CT input cable shall preferably be terminated at one place either the control side or relay side terminal block of the panel on one separate terminal block.

## 5.11 WIRING

5.11.1 All panel wiring shall be done with 1100 V grade PVC insulated single core, tinned annealed ~~stranded~~ copper conductors for service in extremely tropical climate. The PVC wires shall conform to latest version/revision of IS: 694 and duly tested for flammability test as per IS: 10810 (Part 53)-1984. The wiring shall not be prone to attack by vermin, i.e. mice, white ants, cockroaches etc.

**5.11.2** The size of wires in the meter and relay circuits connected to the current transformers shall not be less than 4 sq.mm copper and in potential and other circuits not less than 2.5 sq.mm copper. ~~The wires shall be stranded, with strands of not less than 0.91 mm (20 SWG).~~

5.11.3 The numbering and scheme of wiring for various circuits in the control and relay panel shall be in accordance with latest version of IS: 5578 and 11353. The following color scheme shall be adopted for the wiring in order to facilitate identification of circuits:

SPECIFICATION NO. <b>TI/SPC/PSI/PROTCT/6072</b>	Effective from: .....	Page 20 of 51
--	--------------------------	---------------

Color of wire	Circuit	
Blue	220 kV or 132 kV or 110 kV or 66 kV current transformer circuit.	
White	220 kV or 132 kV or 110 kV or 66 kV PT circuit.	
Yellow	25 kV potential transformer circuit.	
Violet	25 kV current transformer circuit.	
Red (phase)	240 V a.c. auxiliary	
Black (neutral)	Supply circuits.	
Green	Earth circuit	
Grey	d.c. control circuits	PVC sleeves of colours, red for trip blue for indication circuit, yellow for alarm circuit green for relay and other inter connections to be provided.

A suitable plaque of durable material and indelible description giving the color scheme of wiring shall be provided inside the control board to facilitate quick identification of circuits for maintenance purpose.

5.11.4 Wiring shall be suitably supported and clipped to the frame works. The wiring for interconnections between control and relay panels shall be fixed under the roof of the corridor. All wiring shall be neatly bunched with PVC tape or laced by thread. Where metal clips clamp a bunch of wire, the wires shall be taped together by one or two layers of PVC tape to protect them against mechanical injury. Wiring connected to the space heaters in the panels shall be provided with porcelain beaded insulation for a short distance from the heater terminals and heat resistant bushes of insulating materials shall be provided at the terminal housing outlets. No joints shall be permitted in the wiring.

5.11.5 The terminal ends of all wires shall be provided with numbered PVC ferrules. The ferrules shall be of white color with black lettering thereon. However, for trip circuits, ferrules of red color shall be used. At a point of inter-section where a change of number is necessary, duplicate ferrules shall be provided and marked with proper numbers.

5.11.6 End of all wires shall be provided with terminal lugs which shall be crimped. At terminal connections, washers shall be interposed between wire terminals and holding nuts. The connection studs shall project at least 3 mm from the lock-nut surface. Wire ends so connected at the terminal studs that no terminal ferrule gets masked due to the succeeding connections. The wire ends shall be suitably bent to meet the terminal stud at right angles with the stud axis; skew connections shall not be permitted.

## 5.12 MCB AND FUSES FOR CONTROL CIRCUIT

Suitable rating MCB's of reputed make preferably L&T, Havells, ABB, Siemens, Schneider, **Indoasian** etc. make shall be provided in all potential circuits. MCB's shall be mounted in the interior of the control board and at easily accessible places. The MCBs rating and the identification number, as assigned in the schematic diagram shall be indicated on the MCB. Suitable labels of engraved/print markings indicating the rating, identification number and the circuit in which used, shall also be provided.

## 5.13 SPACE HEATERS AND CONTROL PANEL LIGHTING

5.13.1 Suitable space heaters to operate on 240 V single phase ac supply with Thermostat and 'ON/ OFF' switches shall be provided inside the control board to prevent condensation of

SPECIFICATION NO. <b>TI/SPC/PSI/PROTCT/6072</b>	Effective from: .....	Page 21 of 51
--	--------------------------	---------------

moisture in humid weather.

5.13.2 The interior and central corridors of control panel shall be adequately illuminated by 240 V ac, 20 watt CFL's. The central corridor CFL shall be controlled by door operated switches provided on the doors on either side of the corridor and others lamps shall be controlled by ON/OFF switches provided inside the panel.

5.13.3 Two numbers 5 Amps, single phase, 3 pin plug sockets with switches shall be provided inside the control board at convenient points for use of portable lamps in control and relay panels.

#### 5.14 EARTHING

5.14.1 All current free metallic bodies of equipment/relays etc. on the control board shall be earthed properly. Main earth circuit shall be of 25 x 3 mm tinned copper strip **which shall be placed inside the panels with M8 threads at equal sections for easy connection.** and Individual connections of equipment/relays with main earth circuit shall be by means of ~~2.64 mm~~ **4/6 mm<sup>2</sup> (12-SWG)** tinned annealed copper bare conductor/strips, using tinned copper spade terminals/lugs. Some times as an alternate, PVC insulated **stranded** tinned copper wire of size equivalent to ~~2.64 mm~~ **4/6 mm<sup>2</sup> (12-SWG)** may be provided. Joints shall be avoided as far as possible.

5.14.2 In order to facilitate the earthing of secondary of CTs and PTs inside the control board, suitable earth links of adequate size made of tinned copper/brass shall be provided inside the control board at the appropriate points.

5.14.3 Multiple earthing of current/potential transformer circuits shall be avoided. Main earth connection in the form of 25x3 mm tinned copper strip for each panel shall be brought out to two terminals for connection to the general earthing system of the TSS.

#### 5.15 NAME PLATES/IDENTIFICATION LABELS

5.15.1 All relays, instruments and other electrical devices mounted on the board shall have name plates with rating, serial number and manufacturer's name.

5.15.2 Identification labels of suitable size, indicating functions and numbering of respective equipment e.g. transformers, AT's, semaphore indications, relays, instruments and test blocks etc. shall be provided on the exterior of control and relay panels. Similar labels shall also be provided for all switches, LED's and push buttons provided on the control and relay panels indicating their functions. The purchaser shall supply the scheme of numbering of various equipments in traction substations.

5.15.3 All Indicating labels of adequate length and width made up of aluminum alloy sheet suitably printed with all inscriptions on it, made on the black background with white letters/figures using aluminum anodized screen printing, to provide clear and long-lasting impression shall be provided. The inscription shall clearly convey the function of the device.

5.15.4 Bigger plastic/acrylic plates about 50 mm wide, bearing suitable captions to identify the transformer bay and corresponding outgoing 25 kV feeder, shall be provided on the top of each relay and control panel.

5.15.5 All the identification labels on the exterior of control and relay panels shall be secured with the panel in an elegant manner keeping aesthetic looks of the panels.

5.15.6 Identification labels shall also be provided in the interior of the control panel for such equipment and fittings, which are mounted inside the control panel, the labels of suitable size

SPECIFICATION NO. <b>TI/SPC/PSI/PROTCT/6072</b>	Effective from: .....	Page 22 of 51
--	--------------------------	---------------

indicating function of respective equipment shall be provided.

5.15.7 The labels in the interior of the board under the equipment/relays shall be so provided that they are not obscured due to bunches of wire runs and any other obstructions. Painting of inscriptions shall not be permitted.

5.15.8 Generally, labels shall be provided for following.

Sl. No.	Label description
i)	Main labels to be provided on the top panels.
ii)	Circuit labels to be provided at the bottom of the panels
iii)	Function label under the equipments.
iv)	Push button and indication LED labels.
v)	Equipment numbering labels.
vi)	Control & selector switch labels.
vii)	Labels under fuse and Links.
viii)	Reference labels (Interior of panel)
ix)	Terminal block pillar numbering labels.
x)	Terminal numbers on terminal blocks.
xi)	Function inscriptions on terminal blocks.

#### 5.16 MONITORING OF BLOWER FANS PROVIDED FOR FORCED COOLING OF TRANSFORMER (TYPE-ONAF)

The power transformers shall be provided with single phase 240 V, 50 Hz ac operated blower fans for forced cooling which start automatically, in the event of winding temperature of transformer exceeding a preset limit. For ease of connections, 3-4 blower fans are grouped together electrically. The number of groups for each transformer may be 2 to 5. The temperature sensing is done by the WTI relay and suitable circuit for automatic control of blower fans is provided in the marshalling box of the transformer. Indication LED's, for each group of blower fans, shall be provided on the control panel, which shall light-up when the blower fans of that group are working. A NO type contact in each group of blower circuit is provided for this purpose. The successful tenderer shall ascertain from the purchaser, the actual number of groups of blowers provided for the transformers.

#### 5.17 ADDITIONAL FEATURES FOR 25 kV SHUNT CAPACITOR BANK PANEL

5.17.1 Provision of necessary wiring shall be made in the panel so that when capacitor circuit breaker trips on current unbalance relay, the same shall not close from RCC until a push button provided on the panel is reset manually.

5.17.2 Provision of necessary wiring and timer circuit shall be made so that capacitor bank circuit breaker can be closed from locally/remote only after preset time delay, which shall be settable in the range of 0-10 minutes in steps of 1 minute.

### 6.0 PROTECTIVE RELAYS

6.1 The feeder protection relays in use on IR shall be of numerical type. For technical details of the same refer the following RDSO specifications or latest.

- i) TI/SPC/PSI/PROTCT/5070(Rev.1)-Microprocessor based numerical feeder protection module comprising DPR, WPC, PTF, Inst. OCR and auto reclosure relays.
- ii) TI/SPC/PSI/PROTCT/2983-For Panto flashover protection relay

SPECIFICATION NO. TI/SPC/PSI/PROTCT/6072	Effective from: .....	Page 23 of 51
---	--------------------------	---------------

iii) TI/SPC/PSI/PROTCT/1982 with A&C Slip No.1–Delta-I type high resistive fault selective relay.

6.2 There are no separate governing RDSO specifications for protection relays to be used for transformer, transmission lines and 25 kV shunt capacitor banks however the details for the same have been covered in this specification as under.

6.3 The relays used for protection of traction transformer, 25 kV shunt capacitor bank and transmission line protection shall be of numerical type except master trip, inter trip and additional auxiliary relays, which shall be of electromechanical type.

6.4 The general design features of numerical relays with reference to clause 6.2 shall be as given below.

6.4.1 The numerical relays shall have number of protection elements built in one relay therefore each numerical relay shall be used for carrying out multiple protection functions. The number of protection functions, relay features & characteristics etc. of each numerical relay shall be finalized at the time of design/ drawings approval by RDSO. Only relays successfully type tested and approved by RDSO shall be used.

6.4.2 The relays shall be of the draw-out (Plug-in), switch board type, back - connected and suitable for semi-flush or flush mounting, with dust-tight covers in dull black enamel finish. The enclosure class of module/relays shall be IP 54 as per IEC 60529.

6.4.3 The numerical relays shall have in built contact multiplication relays for each protection and monitoring function. For external connection one NO contacts for each protection elements to trip circuit breaker and one set of NO contacts for each protection and monitoring function shall be available for the purpose of telesignalling to RCC through SCADA and other for Annunciation at control and relay panel.

6.4.4 The current coils/input module shall be rated for 5A for relays on Type - I panels, 5A & 1A for relays on type-II panels and 1 A for relays on type -III panels. The voltage coil shall be rated for 110 V ac. The current coils/input module shall be capable of withstanding  $3 I_n$  continuously and short time rating shall be  $20 I_n$  for 3 sec where  $I_n$  is rated current. The voltage coil shall be rated for 110V ac. The voltage coil shall be capable to withstand 1.15 times of rated voltage continuously and 1.5 times for 3 seconds. Particulars of separately mounted current transformers are given in clause 8.0.

6.4.5 The Protection module shall conform to the test voltage Class -III as per IS: 8686–1977/IS 3231/IEC:60255-27 or latest and product safety requirements as per IEC:60255-27.

6.4.6 The relays shall be designed for continuous service (auxiliary supply) voltage of 110 V dc and shall be capable of satisfactory operation for +15 % and - 30 % fluctuation in voltage.

6.4.7 The relays shall have name plates with rating data, serial number and manufacturer's name marked on them. The metal case shall be provided with separate earthing terminals.

6.4.8 The relays shall be immune to distorted power frequency waveforms caused by the harmonics, phase shifts and transient faults and work on the principle of fundamental waveform extraction. The relays shall be immune to electro-magnetic interference and comply with IEC tests as mentioned in clause

9.2.1.1 (xvii). The relay manufacturer shall study the effect of harmonics present in the existing Railway traction supply system and its effect on the relay pick up values & operating

time of the relay and suitable methodology shall be adopted to eliminate the effect of harmonics.

6.4.9 The relays shall be insensitive to power swings, permissible overloads and transient condition including magnetizing inrush current of locomotive transformers and shall be suitably designed to compensate the effect of fault arc resistance.

6.4.10 The Protection module should have facility to record actual waveform of current and voltage along with all digital and logical status during fault condition. At a time at least ~~100~~ **200** such latest waveforms for currents & voltage shall be storable and shall be retrievable through ~~RS-232 serial communication~~ **USB** port or any other superior type of front end standard communication port with optical interface to limit EMI, accessories and firmware for communication through a Laptop computer and/or suitable external printer. The duration of each disturbance record for current and voltage shall be at least 50 cycles (45 prior to and 5 after trip executed by relay-post fault). The disturbance record shall be triggered from trip operation of relay. Such waveforms shall also be retrievable at RCC through SCADA, suitable software along with compatible protocol for this purpose shall be made available in the relay as well as notebook computer. Relay shall also have a feature for transferring R-X values to RCC through SCADA, relay manufacturer to match the software and protocol to suit the existing SCADA system of any make/firm.

6.4.11 Suitable software shall be supplied along with the numerical relays to download and interpret the fault waveform and other data stored in the relays. The software shall be capable of analyzing the peak, RMS and average values of currents & voltage, dc component of currents, harmonic analysis, of fault current waveforms and determination of fault clearing time, Resistance, Reactance, Impedance, and Phase angle of waveforms. The accuracy of measurements shall be 1ms for time, 0.1 KV for voltages and 0.1 KA for currents. The software shall also be capable of communicating with the relay and viewing and altering of settings though laptop computer and SCADA.

6.4.12 The numerical relay manufacturers shall provide full support for up gradation of the software time to time to maintain the satisfactory performance throughout the useful life of the relay.

6.4.13 The numerical relays shall provide date and time stamping up to 1 ms level for each fault. Relay shall have facility for clock synchronization through SCADA or any other similar synchronization facility like GPS etc.

6.4.14 The Protection module shall be capable of storing minimum 5000 latest events serially with date and time stamp of 1ms accuracy. The events should includes tripping of different protection elements, relay pickup, relay reset, relay blocked due to harmonics or any other restraints, Auto reclosure acted, Auto reclosure lockout, Auto reclosure bypass, CB trip, CB close, changed of status input, relay setting changed, Relay fail, trip circuit monitoring etc. The events shall be retrievable through an external laptop/PC as well as through SCADA system at RCC.

6.4.15 Operation counters shall be provided for each protection function with resetting facility.

6.4.16 The numerical relays shall be compact in nature and every effort shall be made to minimize the hardwiring within the relays and maximum components shall be on the PCB's. The SMT (surface mounted technology) PCB's shall only be used. Suitable conformal coating to be provided on the PCBs.



The contact multiplication shall as far as possible be done through software. For this purpose only one set of NO/NC auxiliary contact from each switchgear shall be terminated on the C&R panel terminal block.

6.4.17 The design shall be fail-safe and while designing the numerical relays, adequate redundancy shall be provided in various functional elements.

6.4.18 The Protection module shall have self-diagnostic features. Suitable displays/contacts for confirming the module healthiness or defects shall be available for alarm at TSS and telesignal at RCC through SCADA. Trip contact of relay fail shall also be available to trip circuit breaker.

6.4.19 Numerical relays shall have high contrast backlit LCD display of size at least 20x4 LCD characters for display of relay status, settings, on line parameter (current, voltage, Impedance & Phase angle) etc.. The parameters of the module shall be settable through a membrane keypad. Manufacturer shall clearly indicate/furnish the sampling rate, accuracy and range of above measurements at the time of design & development to RDSO.

Bright LEDs shall be used for display of relay healthiness/defect, trip indications of the each protection function and status of monitoring function.

6.4.20 The numerical relays shall be capable to show on line current & voltage parameters on the LCD display. Manufacturer shall clearly indicate/furnish the sampling rate, accuracy and range of above measurements at the time of design & development to RDSO.

6.4.21 Provision shall be available to reset the indicating LEDs of protection module from RCC through SCADA. For this purpose, suitable NO/NC contact shall be provided in the module.

6.4.22 The size of the module shall be suitable for flush mounting design for fitting on existing/new control and relay panels. The actual size shall be decided at the time of design approval.

6.4.23 The relay settings and stored data shall not be corrupted/erased/changed in the event of auxiliary power i.e. 110 V dc failure.

6.4.24 SCADA system is available for Railway traction application. For its full utilization in controlling/monitoring of protection system, numerical relays shall be capable of communicating with the RTU or other IED's based on standard IEC 60870-5-103 protocol for transfer of information stored in relays to the RTU. The relay shall have necessary hardware and firmware interface for this purpose.

The relay module should be capable of supporting following main functions of SCADA (even if some of these may be required in future).

- (i) User interface for the interaction with the control system and the controlled process.
- (ii) Automatic supervision and control.
- (iii) Alarm and event handling.
- (iv) Data acquisition, calculating and reporting.
- (v) Parameter setting.
- (vi) Disturbance data upload.

6.4.25 Suitable password protection shall be provided on the relays to avoid unauthorized changes in the relay settings.

6.4.26 The making & breaking capacity and rated current of output contacts of the relays shall be adequate to operate the associated output relays/circuit breaker. Suitable snubber to

SPECIFICATION NO. <b>TI/SPC/PSI/PROTCT/6072</b>	Effective from: .....	Page 26 of 51
--	--------------------------	---------------

be provided across the coil.

6.4.27 The module shall also be capable to display I (fault current), V (voltage), R (resistance), X (reactance), Phase angle, fault clearing time and fault date & time (wherever applicable) of latest 100 faults at relay LCD, if it is not possible to display these parameters simultaneously on LCD display, then these parameters may accommodate in two or more window and displaying by pressing scroll Key. The CT's & PTs provided at TSS may have different ratio, hence to display the actual value (line value) of I, V, R, X etc. the CT primary current shall be settable in the range of 100 to 3000A in the steps of 50A and PT primary voltage shall be settable in the range of 20000V to 30000V in steps of 500V. On line current, voltage, Impedance and phase angle shall also be displayed on relay LCD.

6.1.28 The terminal code of the module shall be marked on the side or back of the relay, where they are visible easily.

6.1.29 The rating of relay terminals shall be 10 A continuous and 150 A for at least one second at 110 V D.C.

6.1.30 The modules shall be of industry standard design for continuous operation in the traction substation environment which besides the other environmental requirements being in the vicinity of the Railway tracks. The entire system may be considered as a protection system.

6.4.31 The relays shall generally conform to following standards

(i)	Dielectric Withstand	2kv, 50 Hz for 1 min between circuit to earth/circuit to circuit (IEC 60255-27, IS: 3231, IS: 12083 Pt.II)
(ii)	Impulse voltage test	5 kV, 1.2/50 micro seconds (IS: 8686/ IS: 3231/IEC-60255-27, IS: 12083 Pt.II )
(iii)	High frequency disturbance	IEC 60255- 27, IS: 3231 part-I section-III <u>Longitudinal mode</u> 2.5kV, 1 Mhz across auxiliary dc and current/voltage sensing terminals an earth. <u>Transverse mode</u> 1 kV, 1 Mhz across auxiliary dc and
		current/voltage sensing terminals.
(iv)	Contact data	IS: 3231 part-I, IS : 12083 part-I
a.	Current carrying capacity	5 A, Continuously at 110 V DC/ 230 V AC
b.	Making & carry 250 V ac, 50 Hz for 3 seconds:	30 Amps
c.	Breaking: 220V, 50-60 Hz Cos Ø 0.4 220 V dc, L/R = 45 mili sec	5A 0.5 A
d.	Auxiliary power consumption at 110V DC	<15 W – De energised <30 W – Energised
e.	VA burden a) PTcircuit b) CTcircuit	Less than 5VA Less than 3VA
f.	Resetting time	150 ms to 200 ms

SPECIFICATION NO. <b>TI/SPC/PSI/PROTCT/6072</b>	Effective from: .....	Page 27 of 51
--	--------------------------	---------------

## 7.0 SCHEME OF PROTECTION

The scheme of protection provided at traction substations shall comprise of the following four systems:

- (a) Protection of the 220/27 kV or 132/27 kV or 110/27 kV or 66/27 kV transformers installed at the traction substation.
- (b) Protection of the 25 kV traction overhead equipments.
- (c) Protection of shunt capacitor bank equipment (if asked for by the purchaser in the tender).
- (d) Protection of 220/132/110/66 kV transmission lines (if asked for by the purchaser in the tender).

## 7.1 SCHEME OF PROTECTION FOR TRACTION TRANSFORMER

7.1.1 The complete protection of transformer shall generally be covered in three numerical relays. Two relays shall cover the entire protective functions of the traction transformer primary and secondary sides as detailed below.

- (i) Restrictive Earth Fault protection (REF)
- (ii) Instantaneous OCR (only for primary side).
- (iii) IDMT OCR with additional elements of minimum 3 stage independent current and time settable definite time over current relays with enable/disable facility
- (iv) CB trip circuit supervision relays.
- (v) Contact multiplication function for CB AP/GP low alarm, AP/GP low trip & lockout.
- (vi) Other transformer auxiliary alarm relay contact multiplication function.

7.1.2 Third relay shall cover the differential protection. For digital communication and disturbance record of transformer auxiliary relay trip function, the differential relay shall have a feature to sense the trip status of transformer auxiliary relay and communicate with SCADA RTU. The disturbance record (actual waveform of current and voltage along with digital and logical status) of transformer auxiliary relay trip shall also be available in the differential relay.

7.1.4 The contact multiplication functions of transformer auxiliary trip relay shall be done through electromechanical type auxiliary relay. This relay shall be of single element (individual relay shall be provided for PRD trip, Buchholz trip, oil temperature trip and Winding temperature trip) or multi element (4 elements). The auxiliary relay shall have at least 4 numbers NO contact of each multiplication function for CB trip, annunciation, telesignalling and spare. The auxiliary relay shall be of hand reset type. The operating time of auxiliary relay shall not be more than 15 ms.

7.1.5 The relay manufacturer may propose a different arrangement to cover all protection function of the transformer with the approval of RDSO at the time of prototype design & drawings approval.

## 7.1.6 REQUIREMENTS OF TRANSFORMER PROTECTION RELAYS FUNCTION

### 7.1.6.1 DIFFERENTIAL PROTECTION

Protection against internal faults shall be provided by means of a sensitive single-pole differential relay. The relay shall be of the high-speed type and operate in less than two cycles. The following features shall be incorporated in the relay:

- a. There shall be no necessity for changing the setting of the relay when the transformer tap is changed. The transformer shall be provided with taps from -15% to +10%. Latest RDSO specification for traction transformer can be referred.

SPECIFICATION NO. <b>TI/SPC/PSI/PROTCT/6072</b>	Effective from: .....	Page 28 of 51
--	--------------------------	---------------

- b. Necessary harmonic restraining features shall be incorporated to prevent operation due to in-rush of magnetization current when the transformer is charged either from the HV or the LV side.
- c. The relay shall not operate for maximum through fault currents.
- d. The current setting of the relay shall be adjustable, preferably between the range of 5% and 80% in steps of 5% or less. The minimum current setting shall be as low as possible to obtain better sensitivity.
- e. Adjustable bias setting shall also be provided. The bias at minimum operating current setting shall be 10 to 50% in steps of 5% to suit the tapping range of the traction transformer and other design considerations.

The relay shall be connected to bushing type current transformers provided in the bushings of traction transformers. Preferably the relay shall have facility to match different bushing CT ratios through software otherwise interposing current transformers of suitable rating with matching characteristics of knee point voltage, excitation current etc. may be provided with the differential relay in order to boost up the bushing CTs secondary current, at full load, to a value equal to relay rated current. Magnetization and ratio error curves for the current transformers are supplied to the successful tenderer to enable him to match the characteristics of the relays and interposing CTs with those of the current transformers.

#### 7.1.6.2 EARTH - LEAKAGE PROTECTION

Protection against internal earth faults within the transformer shall be provided by means of a sensitive, high speed, earth-leakage instantaneous relay of very low pick up current. Such relays shall be provided separately of both the primary and secondary sides of the transformer. The current setting for this relay shall be adjustable between 5% and 40% of 5 Amps in step of 1%. The operating time of the relay shall not exceed 1.5 cycle for current of 5 times the relay setting.

#### 7.1.6.3 OVER-CURRENT PROTECTION

Protection against over current shall be provided by means of single-pole, non- directional over-current relay with inverse definite minimum time lag characteristics both on the primary and the secondary sides of the transformer. Further, an additional instantaneous over-current relay shall be provided on the primary side. The over-current relay on the secondary side shall also serve as back-up protection against faults in the 25 kv overhead equipment and also against bus faults, etc. The over-current relays on the primary side shall serve as back up to the over-current relay on the secondary side as well as back up to differential and earth leakage relays against heavy faults. Proper discrimination shall be maintained in the operation of these two sets of over-current relays. The setting on these relays shall be adjustable as explained below:

S. No.	Description of the relays	Current setting	Time multiplier setting.
1.	IDMT over current on primary side.	50% to 280% in steps of 1% IDMT curve: 3 sec. at 10 Ir	0.01 – 1 (In steps of 0.01 )
2.	*Instantaneous over current on primary side.	200% to 1600%	-
3.	IDMT over current on secondary side.	50% to 280% in steps of 1% IDMT curve: 3 sec. at 10 Ir	0.01 – 1 (In steps of 0.01)

\* The instantaneous element time shall be within 20 ms at the 1.5 times the setting value.

SPECIFICATION NO. <b>TI/SPC/PSI/PROTCT/6072</b>	Effective from: .....	Page 29 of 51
--	--------------------------	---------------

#### 7.1.6.4 OVERLOAD PROTECTION FOR TRANSFORMER

Traction transformer is generally designed to handle the over load of 150% for 15 minutes and 200% for 5 minutes provided that two consecutive over loads occur only after an interval of at least 3 hours. The above IDMT curve with 3sec at 10 times of current setting do not permit full utilization of the over load capacity of traction transformers. To utilize the same the relay manufacturer shall design & develop the suitable over load protection using the three-stage definite time OCR in the numerical relays for the transformer which should provide protection against over loading defined as per transformer over load operating cycle (refer latest RDSO specification of traction transformer & transformer manufacturers data sheets). The detailed characteristics, setting parameter and calculations shall be submitted to RDSO at the time of design / drawings approval.

#### 7.1.6.5 INTER TRIPPING RELAY

The differential and earth leakage relays (both on the primary and secondary sides) along with over-current relays on primary side shall cause inter-tripping of the HV and LV circuit breakers associated with the transformer. The inter-tripping of the associated transformer circuit breakers on HV and LV sides shall also be affected due to other faults in the transformer, namely Buchholz trip, excessive winding temperature and excessive oil temperature trip. The IDMT over-current relay on the secondary side shall, however, trip the respective circuit breaker on LV side only. The inter-tripping of associated transformer circuit breakers envisaged above shall be affected through a high-speed tripping relay with hand reset contacts. Such inter-tripping relay shall lock the closing of circuit breakers from all modes of closing commands viz. remote control, local control at the panel and also at the circuit breaker mechanism, until the inter-trip relay or the lock out relay (if provided separately), is reset manually. The inter-trip relay shall be a voltage-operated electromagnetic relay with an operating time of the relay not exceeding 10 ms.

#### 7.1.6.6 OTHER PROTECTIVE DEVICES

The transformers as supplied by the purchaser shall be fitted with the following additional protective devices:

- a. Low oil level alarm.
- b. Buchholz relay with alarm and trip contacts.
- c. Oil temperature indicator with alarm and trip contacts.
- d. Winding temperature indicator with alarm and trip contacts.
- e. Pressure relief device with alarm and trip contacts.

Auxiliary contacts of these shall be wired up to a weatherproof terminal box mounted on the transformer by the transformer manufacturer. The connections shall be extended to the alarm and trip circuits as well as to annunciation scheme provided on the control panel by the successful tenderer.

### 7.2 SCHEME OF PROTECTION FOR 25 KV OVERHEAD EQUIPMENT

The overhead equipment's are protected against short circuits/earth faults and over-loads by means of feeder circuit breakers. Normally the tracks on one side of the substation shall be fed through one feeder circuit breaker. In case of defect on one feeder, the other feeder circuit breaker is arranged to feed tracks on both sides of the sub-station. For details of the feeder protection refer to the RDSO specifications as mentioned in clause No. 6.1. The manufacturer of C&R panel as per this specification shall study these RDSO specifications in order to successfully integrate the complete protection scheme at the TSS.

7.2.1 At present all approved feeder protection relays consists of following in built

SPECIFICATION NO. <b>TI/SPC/PSI/PROTCT/6072</b>	Effective from: .....	Page 30 of 51
--	--------------------------	---------------

protection functions.

- (i) Distance Protection
- (ii) Protection against wrong phase coupling
- (iii) Instantaneous over current protection
- (iv) Protection against PT fuse failure.
- (v) Auto reclosure function.

The delta-I and Panto flash over protection functions are available in separate relays.

7.2.1.1 The feeder protection modules shall also have a feature of feeder breaker back up vide which LV breaker is tripped after a set time of 0 to 5000 ms. adjustable in steps of 1 ms. in case feeder breaker fails to clear the fault despite feeder protection relay giving trip command. The wiring for this purpose for both transformer LV breakers shall be ensured in the control and relay panel.

#### 7.2.2 MASTER TRIP RELAY

All feeder protection relays as explained above shall trip the corresponding feeder circuit breaker in case of fault, through a high-speed self-reset, electromagnetic type master tripping relay. The relay operating time shall not be more than 10 ms. and its resetting time shall not be more than 100ms. The relay shall be capable of handling the current of the CB trip coil.

#### 7.3 SCHEME OF PROTECTION FOR SHUNT CAPACITOR BANK (IF REQUIRED BY PURCHASER)

The protection system for shunt capacitor bank if asked for by the purchase, shall include protection against over current/overload, over voltage, under voltage and unbalanced current. The complete protection functions of a 25kV shunt capacitor bank shall preferably be covered in a single numerical relay along with CB trip circuit supervision, contact multiplication for CB AP/GP low alarm, AP/GP low trip functions.

##### 7.3.1 IDMT OVER CURRENT RELAY

Single pole IDMT Over current relay with the following setting range shall be provided.

Current setting	Time multiplier setting.
20% to 200% in steps of 1% IDMT curve: 3 sec. at 10 Ir	0.01 – 1 (In steps of 0.01)

##### 7.3.2 OVER VOLTAGE RELAY

Over voltage protection shall be provided with inverse time characteristics with voltage settings range 100% to 200 % in steps of 1%, the IDMT operating curve shall be 1.5 N = 7.0 seconds at TMS = 1, the TMS shall be settable 0.01 to 1.0 in the steps of 0.01. The over voltage relay shall be energized from a potential transformer connected to the main bus bar on the incoming side of the circuit breaker controlling the capacitor bank. If required an interposing voltage transformer (IVT) of suitable ratio shall be used for matching the capacitor over- voltage withstand characteristics.

##### 7.3.3 UNDER VOLTAGE RELAY

The voltage setting range of under voltage relay shall be 20% to 90% in steps of 1%, the IDMT curve shall be of 5.0 at no voltage at TMS= 1.0, the TMS shall be settable from 0.01 to 1.0 in the steps of 0.01. This protection function shall work in conjunction with a timer to enable the capacitors to discharge before reclosure. The relay provided for this purpose shall be connected to the bus potential transformer. Also, a time delay relay shall be included with

SPECIFICATION NO. <b>TI/SPC/PSI/PROTCT/6072</b>	Effective from: .....	Page 31 of 51
--	--------------------------	---------------

adjustable setting of 0 to 10 minutes in steps of 1 minute to provide a time lag before the breaker can be reclosed. However, this relay shall not be required if a timer is included in the closing circuit of its associated breaker to prevent its reclosing within 10 minutes.

#### 7.3.4 CURRENT UNBALANCE RELAY

The capacitor bank shall be protected by means of unbalance current protection. The capacitor bank shall be connected as a bridge and an unbalance sensing current transformer shall be provided. The current transformer ratio shall be chosen so that even one capacitor element failure can be detected. The relay used shall be a harmonic insensitive over current relay with fixed time delay characteristic. The current shall be settable from 2.5% to 100% in the steps of 1% and operating time shall be settable from 0 to 1 sec in the steps of 10ms.

7.3.5 The HT capacitor bank protection relays shall be suitable for operation from 25 kV current transformers and 25 kV potential transformers of the following particulars:

S. No	Description	CT	CT (for unbalance protection)	PT
1.	Rated system voltage	25 kV rising	upto 30 kV	
2.	Rated transformation ratio.	200-100/5	2/1 OR 5/1	25000/110 V
3.	Rated burden	30 VA	30 VA	100VA
4.	Accuracy class	5P IS:2705 (pt.III)- 1992	CI-1 IS:2705 (pt.II)- 1992	3P IS: 3156 (pt. III) 1992
5.	Rated accuracy limit factor	15	-	-

#### 7.4 SCHEME OF PROTECTION FOR TRANSMISSION LINES (IF REQUIRED BY PURCHASER)

7.4.1 The protection shall comprise of minimum three- zone standard distance scheme to cover all type of phase and earth faults on the transmission lines.

7.4.2 The setting range of the relays shall be such that line length of at least upto 150 km shall be covered in the first zone, but faults on the secondary side of the traction transformer are not looked into.

7.4.3 The setting on the distance relay shall be adjustable in suitable steps for distance & time delay for second and third Zone, the first zone being instantaneous. The tenderer shall furnish complete setting ranges available and the method of calculating the settings for different ratio of current transformers.

7.4.4 The distance protection shall be suitable for use with single/double circuit three phase as well as two phase lines since sometimes only two phases of the transmission line may be strung for supply to the tail end sub- station. The tenderer shall clearly state the limitations, if any, imposed on the protection system due to this proviso. Suitable scheme for supervision of secondary fuse failure of the PT<sub>s</sub> in circuits shall also form part of this protection scheme.

7.4.5 Back up protection to the distance scheme shall be provided by means of: -

SPECIFICATION NO. <b>TI/SPC/PSI/PROTCT/6072</b>	Effective from: .....	Page 32 of 51
--	--------------------------	---------------

- a) Non-directional inverse definite minimum time (IDMT) over current relays with adjustable current settings in the range of 80% to 320% and time setting of 0-3 sec. at ten times current setting.
- b) Non-directional IDMT earth fault relays connected in the residual circuit of the current transformers with adjustable current setting range and time setting range of 0-3 secs.

7.4.6 Auxiliary trip relays shall be provided, if required, to work in conjunction with the main and back up relays to trip the 132 kV line circuit breakers.

7.4.7 The above details of the transmission line protection are only indicative. Purchaser shall clearly furnish the requirements along with details of transmission lines like voltage class, line diagrams/schematics and CT, PT ratios etc.

### 7.5 INCOMING HV LINE PROTECTION (TO BE PROVIDED BY SUPPLY AUTHORITY)

7.5.1 Fiber optic line differential protection

7.5.2 Directional over current relay

7.5.3 LBBU relay (LBB-breaker failure relay)

7.5.4 Under voltage relay with time delay

7.5.5 Over voltage relay with time delay

### 8.0 PARTICULARS OF POTENTIAL AND CURRENT TRANSFORMERS

8.1 The relays for transformer protection shall be suitable for operation from current transformers to the following particulars.

Sl. No.	Current Transformer	Ratio		Burden	Class of accuracy as per IS: 2705 (part iv)	Rated accuracy limit factor
1.	Bushing CTs	21.6 MVA	30 MVA			
i)	220/27 kV Transformer HV LV	200/5 1600/5	300/5 3000/5	- -	PS PS	- -
ii)	132/27 kV Transformer HV LV	330/5 1600/5	600/5 3000/5	- -	PS PS	- -
iii)	110/27 kV Transformer HV LV	400/5 1600/5	600/5 3000/5	- -	PS PS	- -
iv)	66/27 kV Transformer HV LV	660/5 1600/5	1200/5 3000/5	- -	PS PS	- -
2.	Separately mounted CTs on HV side					



SPECIFICATION NO. <b>TI/SPC/PSI/PROTCT/6072</b>	Effective from: .....	Page 33 of 51
--	--------------------------	---------------

	220 kV CT 132 kV CT 110 kV CT 66 kV CT	200-100/5 400-200/5 400-200/5 800-400/5	30 VA 30 VA 30 VA 30 VA	5P 5P 5P 5P	15 15 15 15
3. Separately mounted CT <sub>s</sub> on LV side.					
	25 kV CT	1000-500/5 1500-750/5 3000-1500/5	60 VA 60 VA 60 VA	5P 5P PS	15 15 -
4. Potentials Transformer					
	25 kV PT Type I (for line indication )	25000/100V	30 VA	Accuracy class 6 p As per IS: 3156 pt. III-1992	-
	25 kV Type II (for line Protection)	25000/110V	100 VA	Accuracy class 1.0 as per IS: 3156 pt. II 1992 & 3 P as per IS 3156 pt. III-1992	-

For details of the bushing current transformers, RDSO/purchasers Specification No. ETI/PSI/118(10/93) A&C 1 to 8 and TI/SPC/PSI/30TRN/2070 for respective power transformers shall be referred.

8.2 The relays for transmission line protection shall be suitable for operation from current and potential transformers as per the details furnished by the purchaser in its tender document.

8.3 The drawing No. ETI/PSI/024-1 and ETI/PSI/0228-1 showing the proposed schemes of connections at the double/ single transformer substations for the location of various current & potential transformers and protective relays is shown in the Annexure-F and G.

8.4 The normal load current of a 25 kV circuit is 800 A with 21.6 MVA and 1111A with 30 MVA transformer. The circuits including the transformer are however designed to take 50% overload for 15 minutes and 100% overload for 5 minutes. Normally, 500-1000/5 or 750-1500/5 or 3000-1500/5 CT ratio is used in the instrument and relay circuits for 25 kV current transformers.

8.5 Any variation of the CT, PT's from Para 8.1 shall be furnished in the relevant tender papers, which should be referred to by the tenderer. Any additional requirements of CT<sub>s</sub> and PT<sub>s</sub> (like knee-point voltage of CT<sub>s</sub>), if any, shall also be clearly indicated in the tender offer.

8.6 The location of various potential and current transformers in the circuits is indicated in the lay out drawings of traction substations, given in the relevant substation tender papers. The drawings indicating the proposed scheme of connections at the substations for the instruments and protective relays are also given in the substation tender papers. The tenderer may however furnish alternative proposals, if any, for consideration of the purchaser.

Note: - The two transformers in a substation may be operated in parallel if required due to increase in load if all the condition for paralleling are satisfied. To enable this, dual ratio 25 kV current transformer (1000-500/5, 1500-750/5 and 3000-1500/5) are specified.

#### 9.0 TESTING OF CONTROL & RELAY PANELS AND NUMERICAL RELAYS COVERED VIDE THIS SPECIFICATION

SPECIFICATION NO. <b>TI/SPC/PSI/PROTCT/6072</b>	Effective from: .....	Page 34 of 51
--	--------------------------	---------------

## 9.1 GENERAL

9.1.1 The first control and relay panel and protection relays developed as per this specification shall be type tested by RDSO. Manufacturers developing only control and relay panel shall ensure that protective relays to be provided in C&R panel shall be taken from RDSO approved sources & make only. Manufacturers who want to develop relays and C&R panel both, the relays must be prototype cleared by RDSO before offering the panel for prototype test.

9.1.2 The manufacturer of numerical relays (covered under this specification) and control & relay panel shall submit technical details, design drawings to the RDSO for approval. Only after approval of designs and drawings the manufacturer shall take up manufacture of the prototype relays or panels or both. It shall be clearly understood that any changes required to be done in the prototype as required by RDSO shall be done expeditiously.

9.1.3 Before giving the call to RDSO for inspection and testing of the prototype of the system, the manufacturer shall submit a detailed test schedule consisting of schematic circuit diagrams for each of the tests and nature of the test, venue of the test and the duration of each test and the total number of days required to complete all the tests at one stretch. Once the schedule is approved, the test shall invariably be done accordingly to this schedule. However, during the process of type testing or even later, RDSO representative reserves the right to conduct any additional test(s) besides those specified herein, on any equipment/sub-system or system so as to test the system to his satisfaction or for gaining additional information and knowledge. In case any dispute or disagreement arises between the manufacturer and RDSO during the process of testing as regards the type tests and /or the interpretation and acceptability of the type test results, it shall be brought to the notice of the Director General (Traction Installation), RDSO whose decision shall be final and binding.

## 9.2 TYPE & ROUTINE TESTS ON PROTECTION RELAYS AND C & R PANEL

### 9.2.1 PROTECTION RELAYS

#### 9.2.1.1 TYPE TESTS

The protection relays covered by this specification shall be type tested as per IS:3231, IS: 12083 IS:8686, IEC 61000 & IEC: 60255. The following type tests shall be carried out on the prototype relays by RDSO.

- i) Operating characteristics tests including verification of all relay functions/features including operating time, reset time, operating and reset value.
- ii) Insulation resistance test- should be 10 mega ohm or more between the electric circuit and earth with 1000 V.
- iii) Measurement of burden (VA).
- iv) Measurement of power consumption (watts)
- v) Over load test.
- vi) Impulse voltage withstand test applicable to test voltage class III as per IEC:60255-27.
- vii) Temperature rise test
- viii) Effect of DC voltage variation (110 V DC +15 % / -30 %)
- ix) Making and breaking capacity tests of contacts.
- x) Dielectric test as per IEC 60255-27
- xi) Product safety requirements test as per IEC:60255-27.
- xii) Enclosure Protection Test IP 54 as per IEC:60529.
- xiii) Communication standard protocol as per IEC:60870-5-103
- xiv) Vibration test- as per IEC 60255-21-1, Class-I- Frequency 10-150 Hz, Acceleration  $1g_n$  in all 3 axis, 20 sweep @ 1 octave/minute.

SPECIFICATION NO. <b>TI/SPC/PSI/PROTCT/6072</b>	Effective from: .....	Page 35 of 51
--	--------------------------	---------------

- xv) Endurance test-Mechanical endurance test for 10000 operations as per IEC 60255-1.
- xvi) Environmental test
  - a) Dry heat test as per IEC 60255-1/IEC60068-2-2 (This will test from +20 to +70 OC)
  - b) Dry heat test at maximum storage temperature as per IEC 60255-1/ IEC60068-2-2
  - c) Cold test as per IEC60255-1/IEC60068-2-1 (This will test from -25 to +25 OC)
  - d) Cold test at minimum storage temperature as per IEC 60255-1/ IEC60068-2-1
  - e) Change of temperature as per IEC60255-1/ IEC60068-2-14 (this will test from -25 to + 55 OC)
  - f) Damp heat test, steady state as per IEC 60068-2-78
  - g) Damp heat test, cyclic as per IEC 60068-2-30
- xvii) EM Compatibility tests
  - a) 1 MHz burst immunity test as per IEC 60255-26 & IEC61000-4-18 : Common Mode: 2.5kV Differential mode: 1kV Duration: 2 sec
  - b) Electrostatic Discharge Test as per IEC 60255-26 & IEC61000-4-2 Contact Discharge 6kV Air Discharge 8kV
  - c) Radiated, radio-frequency, electromagnetic field immunity test as per IEC 60255-26 & IEC61000-4-3 Frequency Range: 80MHz – 1000MHz, Modulation: 80% AM @ 1kHz, Field Strength 10V/m
  - d) Electrical fast Transient or burst requirements as per IEC 60255-26 & IEC61000-4-4.
  - e) Surge immunity as per IEC 60255-22-5 & IEC61000-4-5.
  - f) Immunity to Conducted disturbances induces by radio frequency field as per IEC60255-22-6 & IEC61000-4-6.
  - g) Voltage dips, short interruptions and voltage variations on d.c. input power port immunity tests as per IEC60255-11 & IEC61000-4-29.
  - h) Power Frequency Immunity Test as per IEC 60255-22-7 & IEC61000-4-8 .
  - i) A.C. ripples in D.C. auxiliary as per IEC 60255-11 & IEC61000-4-17. -

Type tests for which facilities of testing are not available with the relay manufacturer shall be carried out at any reputed & NABL accredited govt/ semi govt. approved laboratories and test reports of the same shall be furnished to the RDSO.

9.2.1.2 If the prototype of the relays conforming to this specification has already been approved in connection with previous supplies to Indian Railways, fresh prototype testing of the relays may be waived off if it had passed the prototype tests earlier and no changes in the design or material used have been made.

9.2.1.3 Only after approval of the results of the tests on the prototype is communicated by RDSO to the manufacturer, he shall take up bulk manufacture and future supplies of the relays & C&R Panel which shall be strictly with the same material and process as adopted for the prototype. In no circumstances material other than those approved in the design/drawings and/or the prototype shall be used for bulk manufacture.

#### 9.2.1.4 ROUTINE TESTS

The following tests on the protection relays shall be carried out during routine tests by Railways/ inspecting agencies at the manufacturer's works as per this specification.

- (i) Visual Checks
- (ii) Insulation Resistance
- (iii) Dielectric strength

- (iv) Setting range and Functional tests

## 9.2.2 CONTROL & RELAY PANEL.

### 9.2.2.1 TYPE TESTS

The following type tests shall be carried out on the first proto type control & relay panel developed as per this specification. If required the successful tenderer shall furnish the type tests report carried out by manufacturer or by Govt. laboratory on all instruments e.g, interposing CTs, LEDs, semaphore, meters, annunciator, hooter/buzzer, wires, terminal connector etc as per latest IS/IEC.

(i) VISUAL CHECK:

General Check of the control panel in respect of dimension, finishing, construction, wiring & ferules verification lay out equipment on the panel, make and rating of instrument etc.

(ii) OPERATION TESTS:

Operation tests on all equipment to prove correctness of wiring of various circuits including indications, alarms, operation of relays and annunciation etc.

(iii) POWER FREQUENCY HIGH VOLTAGE WITHSTAND TESTS:

Voltage test on the panels with all equipment and wiring for a withstand voltage of 2 kV (rms) to earth for one minute.

(iv) INSULATION RESISTANCE TESTS:

Measurement of insulation resistance by using 1000V megger of the complete panel wiring including CT, PT and control circuits with all equipment mounted on the panel.

(v) AUXILIARY POWER CONSUMPTION TEST

Measurement of power consumption of the control & Relay panel with all the relays in energized & de energized conditions.

### 9.2.2.2 ROUTINE TESTS:

The checks and tests as mentioned in clause No. 9.2.2.1 (i to iv) shall be carried out on the complete control and relay Panel by the purchaser or its representative.

## 10.0 TECHNICAL DATA LITERATURE AND DRAWINGS

10.1 The manufacturer developing first C & R panel or Numerical relays covered vide this specification shall furnish the make, type and guaranteed performance, technical and other particulars for all equipment/relays/instruments etc. in the Performa attached as Annexure-C to RDSO along with the internal design details as per clause 10.4 below.

10.2 The tenderer shall furnish the technical specification and descriptive literature of various protection relays covering their protection aspects, instruments, interposing CTs etc. including the characteristics of the relays offered. He shall also submit, along with the tender, the schematic diagram of protection, control and annunciation scheme to enable the purchaser to make assessment of the proposal.

10.3 The tenderer shall indicate his compliance or otherwise against each clause sub-clause of this specification. The tenderer shall for this purpose enclose a separate statement, if necessary, indicating the clause sub-clause reference and compliance or otherwise thereof. Wherever the tenderer deviates from the provision of the clause/sub-clause or offers any alternative equipment, he shall furnish complete details of the proposed deviation/alternative with his remarks to enable the purchaser to make proper assessment of the same. The successful tenderer shall, however, be required to obtain specific acceptance of the purchaser for any deviation/alternative proposed by them.

SPECIFICATION NO. <b>TI/SPC/PSI/PROTCT/6072</b>	Effective from: .....	Page 37 of 51
--	--------------------------	---------------

10.4 Successful tenderer shall be required to submit the following detailed dimensional drawings (including reproducible copies) as per the Railways standard sizes of 210 x 297 mm or multiples thereof, the drawings have to be prepared in Auto Cad. Two sets of same drawings shall be initially submitted to RDSO for scrutiny before prototype development. After approval of drawings and prototype test, the final approved drawings shall also be submitted to DG/TI RDSO in two hard copies for final approval.

- i) Dimensioned drawings of the control panel indicating front and rear views with the layout of instruments, mimic diagram, control switches, indication LED<sub>s</sub> push buttons, relays and other equipments etc. clearly marked.
- ii) Exploded view of the rear and front panel indicating the disposition of various equipment inside the control panel.
- iii) Schematic diagram of d.c. control circuits for transformer protection, OHE protection, shunt capacitor bank protection (if it is asked for by purchaser in the tender) and control of circuit breaker, interrupters and motor-operated isolators (if any).
- iv) Schematic diagram of Alarm, indication circuits (annunciation scheme).
- v) Schematic diagram of a.c. circuits showing connection of CT<sub>s</sub> and PT<sub>d</sub> and associated protective relays.
- vi) Drawing showing the legend of various references/codes adopted for equipment, relays and all other accessories used in the control panel.
- vii) Drawing for name plates/identification labels engraving details.
- viii) Any other drawings considered necessary.

10.5 Only after all the designs and drawings have been approved and clearance given by RDSO to this effect, the manufacturer shall take up manufacture of the prototype for RDSO inspection. It shall be clearly understood that any changes required to be done in the prototype as required by RDSO shall be done expeditiously.

All the type and routine tests on the relays, instruments, interposing CT<sub>s</sub> and any other equipment as the purchaser may desire shall be conducted as per the latest version of respective standards IS/BS specifications applicable.

#### 11.0 ERECTION TESTING AND COMMISSIONING

11.1 The erection and commissioning of relay and panel shall be done by the successful tenderer who shall arrange all tools, plants, instruments and other material required for the purpose at own cost. Tests shall be carried out during erection/commissioning of the panel at the site. The successful tenderer shall be required to submit to the purchaser the details of the checks and tests to be carried out during erection and commissioning. Tests shall be carried out on the relay and panel jointly with the purchaser's representatives to check the erection and commissioning of the relay.

11.2 The successful tenderer shall ensure necessary co-ordination with the manufacturers of transformers, protection relays, circuit breakers and interrupters with regard to terminal markings, wiring, scheme of protection, etc. He shall obtain the names of these manufacturers from the purchaser.

11.3 Three sets of the test report in hard copies and one soft copy shall be supplied by the manufacturer to the purchaser for records and reference.

11.4 The following test shall be carried out during erection/commissioning of the relays and panel at the site in presence of the purchaser's representatives to check the erection and commissioning of the relay.

- (i) Fault clearing time characteristics and time coordination and settings of various

SPECIFICATION NO. <b>TI/SPC/PSI/PROTCT/6072</b>	Effective from: .....	Page 38 of 51
--	--------------------------	---------------

- protective relay.
- (ii) Measurement of insulation resistance of the complete panel wiring including wiring between CT, PT and control circuit with all equipments mounted on the panel, by using 1000 V tester.
  - (iii) Lead burden should be measured between current transformer and the relays to check any poor contact in the secondary circuit of CTs. Correctness of CTs and PTs polarity shall be ensured.
  - (iv) Check functioning of the control circuit, switches, push button, auxiliary relays, master trip relays, alarms, annunciations and indications etc. by operating the associated switchgear at TSS without energizing the OHE.
  - (v) All auxiliary relays should be checked at their pickup values and confirm that auxiliary relays reset when voltage and current supply is removed after operation.
  - (vi) Check the functioning and correctness of various telecommand and telesignal circuits.
  - (vii) Check operation of relays with circuit breaker by injecting the primary current by using primary injection test kit. Measure the errors between operating value and set value. Conduct secondary injection test and measure the operating times and pick up values of the relays.
  - (viii) Operate protective relays manually and/or by injecting secondary current/voltage and ensure that appropriate CB tripping, inter tripping of primary and secondary CBs. There should be no mal operation of any circuits and in every tripping appropriate flag indication along with alarm/annunciation should appear.
  - (ix) Railways/purchaser along with contractors shall ensure load tests and confirmatory tests of OHE protective relays as per “Para 20941 and 20942 of ACTM Volume-II (Part-I)”.
  - (x) Any other operational/functional test considered necessary for ensuring safe and correct working of C & R panel.

## 12.0 OPERATION, MAINTENANCE INSTRUCTIONS

12.1 The tenderer shall provide maintenance schedule and troubleshooting instructions for the relays and panel. The supplier shall supply free of cost 6 copies of the Instruction Manuals for operation and maintenance of the equipment to the purchaser.

12.2 The basic maintenance schedule along with the troubleshooting, diagnostic chart shall also be submitted to RDSO in two hard copies and one soft copy in CD for scrutiny and approval.

## 13.0 SPARES AND SPECIAL TOOLS

The tenderer shall quote separately for the spares recommended to maintain the equipment for a period of at least 5 years. The tenderer shall also quote separately for supply of special tools, if any, required for trouble free operation and maintenance. Spare parts/special tools as ordered shall be delivered along with the supply of relays & panels. The purchaser reserves the right to buy the special tools from the tenderer or not. The price quoted against spares and special tools shall be optional unless the same is especially specified in the tender document.

## 14.0 PACKAGING & FORWARDING

The tenderer shall ensure proper packaging of control and relay panels, numerical relays, electronic items and manuals, by using wooden crates, thermocol and polyethylene wrappings, so that there is no damage during the transit and there is no effect of humidity. The handling, loading and unloading instructions along with the list of packages, contents shall be

SPECIFICATION NO. <b>TI/SPC/PSI/PROTCT/6072</b>	Effective from: .....	Page 39 of 51
--	--------------------------	---------------

sent to the consignee separately.

15.0 All the provisions contained in RDSO's ISO procedures laid down in document No.-QO-D-8.1-11, Ver. 1.3 dated 01.07.2020 (Titled "Vendor change in approved status") and subsequent versions/ amendments thereof, shall be binding and applicable on the successful vendor/ vendors in the contracts floated by Railways to maintain quality of products supplied to Railways".

DRAFT

ANNEXURE-ALIST OF ABBREVIATIONS

Abbreviation	Full Form of the Abbreviation
BT	Booster Transformer
C&R	Control and relay
CB	Circuit Breaker
IDM	Inverse Definite Minimum Time lag
T ICT	Interposing CT
IOL	Insulated Overlap
MTR	Master trip Relay
NC	Normally closed.
NO	Normally open
OHE	Over Head Equipment
PTFE	Poly Tetra Flouro Ethylene
RC	Return Conductors.
RTU	Remote Terminal Unit
SP	Sectioning Post
SSP	Sub Sectioning Post
TRD	Traction Distribution
TSS	Traction Sub Stations
WPC	Wrong Phase Coupling
CT	Current Transformer
PT	Potential Transformer
SCADA	Supervisory control and data acquisition system
RCC	Remote Control Centre
OCR	Over current relay
DPR	Distance protection relay
ACTM	AC traction manual



SPECIFICATION NO. TI/SPC/PSI/PROTCT/6072	Effective from: .....	Page 41 of 51
---	--------------------------	---------------

ANNEXURE-BDEFINITIONS & EXPLANATIONS

Item	Definition
Breaking capacity	The maximum current and volt– amperes that the contact is able to interrupt successfully under specified conditions without significant damage to contact.
Contract	Means the contract resulting from the acceptance by the purchaser of the tender either in whole or part
Dead time	Dead time is the period taken by the auto reclose mechanism to close the breaker after the same would have tripped on fault. In other words, the time from the instant of fault detection up to the instant of closing of breaker by auto-reclose system.
Differential protective system	A unit protective system in which an algebraic comparison is made of primary current at two or more points in the power system.
Double ended feeding	The adjacent TSS are on same phase and are connected in parallel. There may or may not be a neutral section on SP for such feeding arrangement.

SPECIFICATION NO. <b>TI/SPC/PSI/PROTCT/6072</b>	Effective from: .....	Page 42 of 51
--	--------------------------	---------------

Making capacity	The maximum current and volt–amperes the contact is able to make successfully under specified conditions without significant damage to the contact.
Operating time	The time, which elapses from the appearance of the abnormal conditions, which cause the operation of the protection until the protection initiates tripping or alarm.
Protected zone	The part of an installation guarded by a certain protection.
Purchaser	The person / agency who has floated the tender for execution of the work on or behalf of the president of India.
Reclaim time	Reclaim time is the duration for which the auto reclosing mechanism remains ineffective after first reclosure of circuit breaker by auto-reclose, irrespective of re-occurrence persistence of fault. In other words, the breaker will not be reclosed second time by the auto-reclose device had the same tripped on fault again within the reclaim time after its first reclosure on the auto-reclose system.
Relay back-up	An arrangement, which provides an additional, relay using the same or different principle of operation from that of the main relay.
Remote back-up	An arrangement at the next station in the direction towards the source which trips after a delayed time if the CB in the faulty section is not tripped.
Sector	Distance between the TSS and the SP
Sub-sector	Distance between the TSS and the adjacent SSP/ SP or the distance between the SP and the adjacent SSP/SP
Tenderer	The vendor, supplier who intends to quote for the tender floated by the purchaser. The agency who shall quote for tender floated by the tenderer.
Time lag	Intentionally introduced time interval between start and completed operation of the protection.
Track circuit	It is the circuit providing passage of traction current through arrangement of track bonding.
Unit protection	A protective system, which is designed to operate for abnormal, conditions inside and remains stable for abnormal conditions outside a specified zone of the protective system.

SPECIFICATION NO. <b>TI/SPC/PSI/PROTCT/6072</b>	Effective from: .....	Page 43 of 51
--	--------------------------	---------------

ANNEXURE-CSCHEDULE OF GUARANTEED PARTICULARS

The manufacturer shall be required to submit the following particulars to the RDSO along with the design drawings of the proto type.

## A. SOGP for control and relay panel

Sl. No.	Description	Manufacturer details	Unit
1.	Name of the manufacturer		
2.	Governing RDSO specifications		
3.	Are you an RDSO approved firm? Even for any other item.		
4.	Permitted range of dc voltage for different panel equipment.		
5.	VA burden of digital meters.		
6.	Type & make of annunciators and their power consumption.		
7.	Type of LEDs, life and power consumption		
8.	Type of terminal block, rating and make		
9.	Type , make & power consumption of LED type semaphore arrangement.		
10.	Dimensions: Length Width Breadth Total Weight (approximate)		
11.	Are there any deviations to the RDSO specifications? If yes enclose clause wise deviations and reasons of deviations.		

SPECIFICATION NO. TI/SPC/PSI/PROTCT/6072	Effective from: .....	Page 44 of 51
---	--------------------------	---------------

## B. SOGP for each protection relays module / element as applicable

Sl. No.	Description	Manufacturer details	Unit
1.	Make / model number of relay / module		
2.	Governing RDSO specification		
3.	Setting range of parameters with steps of Resolution		
4.	Operating time		
5.	Resetting time		
6.	Max. permissible errors in operating parameters		
7.	VA burden		
8.	DC power consumption		
9.	Number and type of communication ports		
10.	User interface type & its features		
11.	Number of pre and post fault waveforms & events stored in relay memory		
12.	Sampling rate of current and voltage		
13.	Down loading and analysis of stored data software		
14.	Digital data available in relay		
15.	Number of spare contacts available		
16.	Short time current rating of input coil (CT)		
17.	Permitted range of DC voltage		
18.	Contact ratings		
19.	Dimensions: Length Width Breadth Weight Cut out dimension		
20.	Any other specific feature of relay firmware and data analyzing software		

SPECIFICATION NO. <b>TI/SPC/PSI/PROTCT/6072</b>	Effective from: .....	Page 45 of 51
--	--------------------------	---------------

ANNEXURE-D

List of equipment to be provided on the control and relay panel given below is indicative. It may be noted that quantity of the equipment shall vary depending upon the purchasers requirements based on lay out (single/double/triple or more lines), number of transformer bays and working conditions (e.g. parallel operation of the transformer) etc.

Purchaser shall clearly indicate the above so that tenderer can realistically assess the requirements of the equipments to be provided on C & R panels.

## 1. EQUIPMENT ON THE CONTROL PANEL

1.	Control switch (TNC) each for CB, BM's
2.	Switch each for Local/Remote Change over for CB, BM's and tap changer control
3.	Automatic semaphore Indicators for CB, BM's
4.	Manually operated Semaphores for isolators
5.	Indication LED <sub>s</sub> for close and open positions of each breaker, interrupters, dc fail supervision, trip circuit fail, PT healthy, dc high/low, tap positions, blower fans etc.
6.	Set of push button and annunciation LED <sub>s</sub> for trip circuit supervision, dc fail, tap changer raise/lower, annunciation and alarms reset/accept/check.
7.	A.C. Ammeters on 25 kV side, Scale 750/1500 A with associated range selector switch. A.C. Voltmeters on 25 kV side Scale 0-30 kV. Power factor meter Digital type smart energy meter on HV side
8.	Annunciation System as this specification
9.	Cut-off switches for disconnection alarm, indication, hooter and annunciator as per this specification
10.	Space heaters with Switches & thermostat (240 V a.c.).
11.	240 V, 5A, 3 pin Socket& Switch.
12.	Cubicle and corridor illumination incandescent lamp with door switches.
13.	Terminal blocks
14.	HRC fuse and MCBs
15.	Earth links.
16.	Any other item considered necessary.
17.	Interposing CT for meters
18.	All protection relays, auxiliary relays as per this specification for a TSS.

GENERAL SCHEME OF TRACTION POWER SUPPLY SYSTEM

Annexure-E

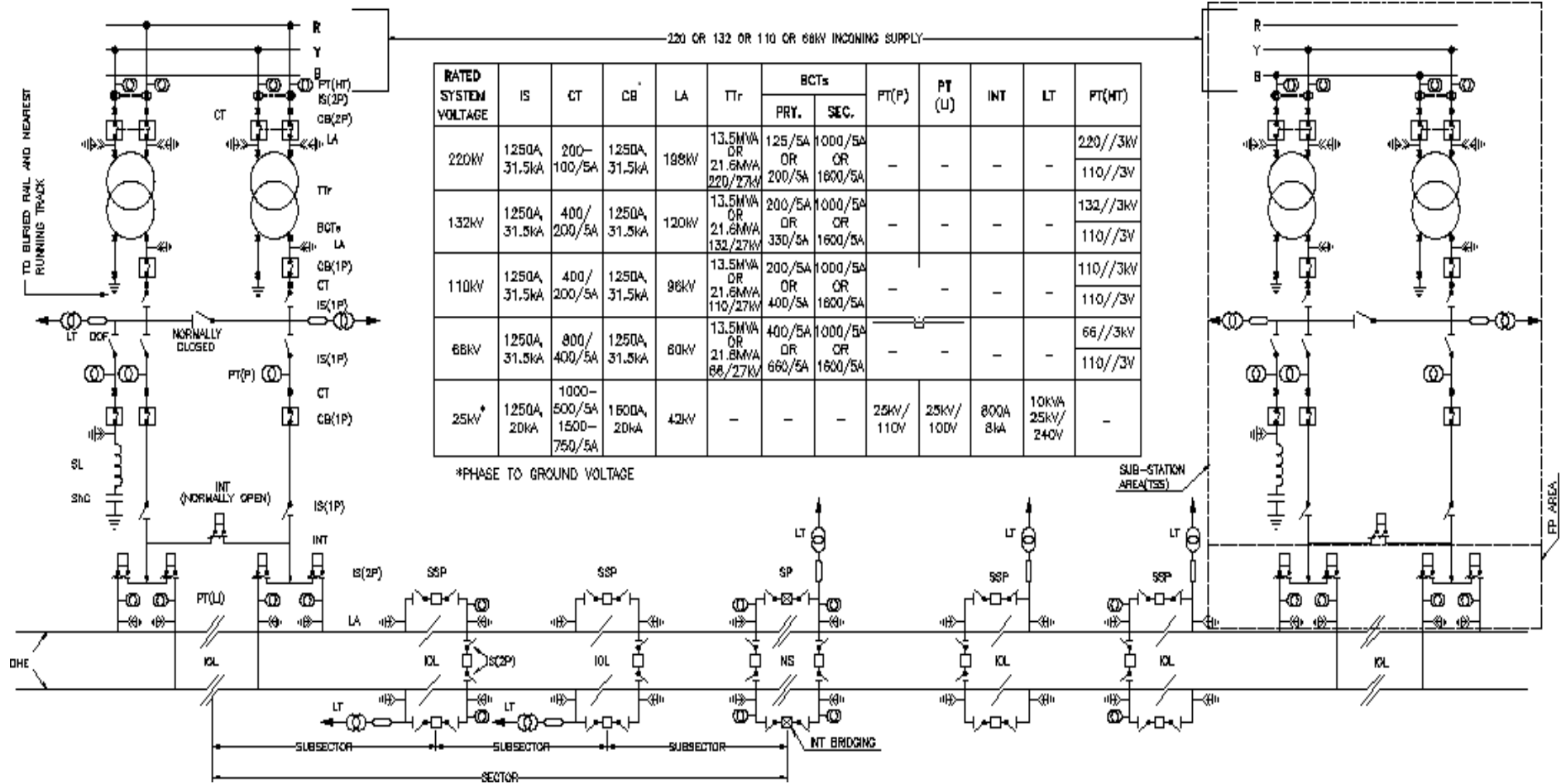

**NOTES:-**

- 25KV SHUNT CAPACITOR BANK COMPLETE WITH CONTROL GEAR, PROTECTION RELAYS, SERIES REACTOR AND ACCESSORIES NECESSARY FOR ITS EFFICIENT OPERATION SHALL ALSO NEED TO BE PROVIDED AT THE RAILWAYS TRACTION SUB-STATION (TSS) WHERE IT IS SPECIFICALLY MENTIONED BY THE PURCHASER.
- FOR DETAILS OF EQUIPMENT AND ITS RATING ETC. LATEST EQUIPMENT SPECIFICATIONS AND THE SUB-STATION LAYOUT DRAWING SUPPLIED BY PURCHASER MAY BE REFERRED.
- THE RATING OF BUSHING CTs WOULD VARY ACCORDING TO THE TRACTION TRANSFORMER CAPACITY.

**LEGEND:-**

IS	ISOLATOR	LT	AUXILIARY TRANSFORMER
CT	CURRENT TRANSFORMER	Shc	SHUNT CAPACITOR
CB	CIRCUIT BREAKER	SL	SERIES REACTOR
LA	LIGHTNING ARRESTER	FP	FEEDING POST
BCTs	BUSHING CTs	SSP	SUB-SECTIONING AND PARALLELING POST
TTr	TRACTION TRANSFORMER	SP	SECTIONING POST
PT(P)	POTENTIAL TRANSFORMER (PROTECTION TYPE)	NS	NEUTRAL SECTION
PT(LI)	POTENTIAL TRANSFORMER (LINE INDICATION TYPE)	IOL	INSULATED OVERLAP
INT	INTERRUPTOR	DOF	DROP OUT FUSE SWITCH
		IP	SINGLE POLE
		2P	DOUBLE POLE

THIS DRAWING SUPERSEDES DRG. No.ETI/PSI/702 AND 707.

"THIS DRAWING IS THE PROPERTY OF RESEARCH, DESIGNS & STANDARDS ORGANISATION (MINISTRY OF RAILWAYS), LUCKNOW-226011, INDIA AND SHALL NOT BE USED, COPIED OR REPRODUCED, IN PART OR WHOLE, WITHOUT PRIOR CONSENT IN WRITING."

**GENERAL SCHEME OF  
SUPPLY FOR 25kV  
50Hz SINGLE PHASE  
TRACTION SYSTEM**

JD/TI Sd/-  
25.8.92ADE/PSI Sd/-  
25.8.92

REF:-

CROSS REF:-

R. D. S. O.

DATE	MOD.	NATURE OF MOD.	INITIAL	DATE	NAME	REV. F
18.04.11	'A'	REVISION MADE OF DATE 20.04.11				
20.04.11	'B'	REVISION MADE AND INKED	BA/-	DR.		
18.04.11	'C'	INITIAL OF 13.5MVA TRANSFORMER ADDED	TC.			
18.04.11	'D'	REVISION OF BNC & SL INTERCONNECT	BA/-	CK.		

ETI/PSI/702-1

SCALE:- N.T.S.

IR

Annexure-F

TYPICAL SCHEMATIC DIAGRAM OF PROTECTION FOR DOUBLE TRANSFORMER TRACTION SUB-STATION

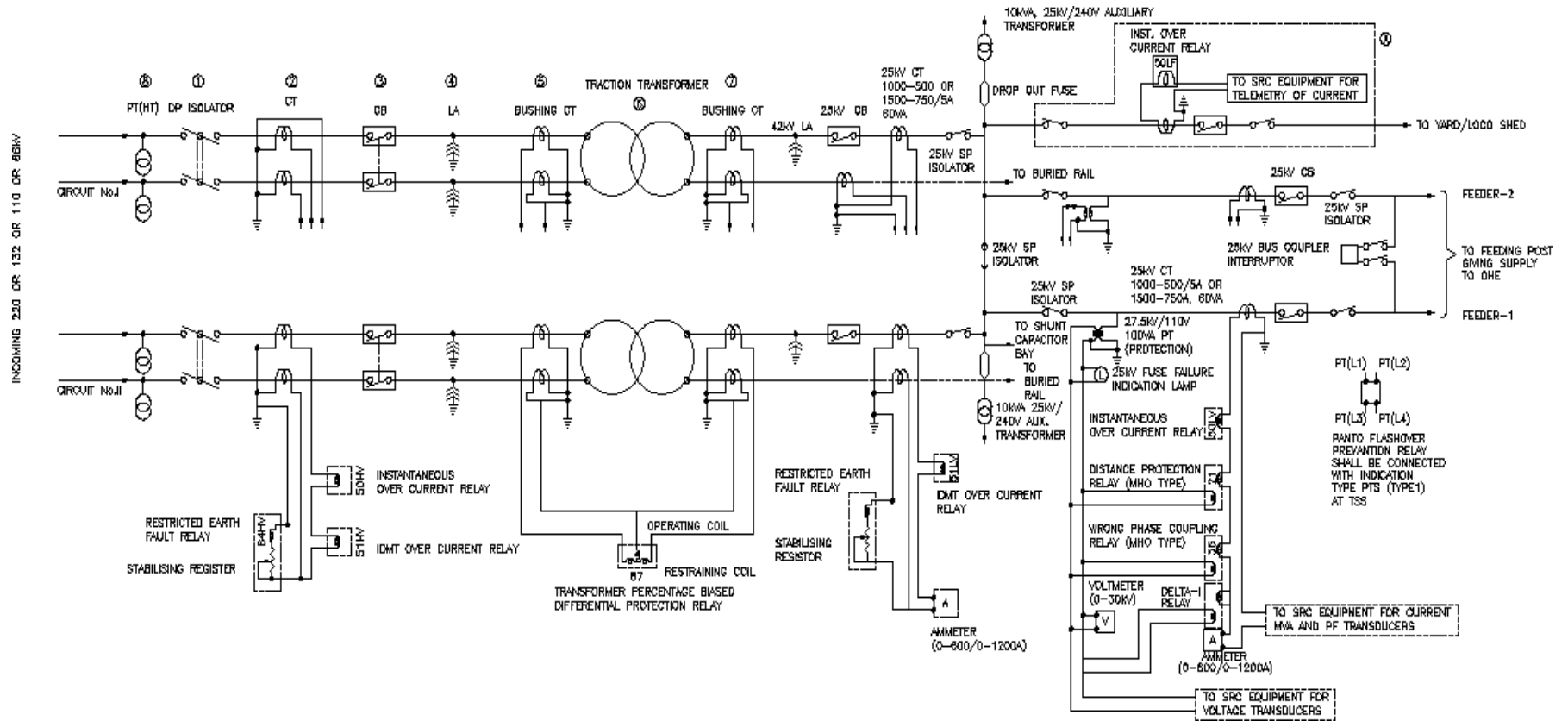







TABLE FOR RATING WITH 21.6/13.5MVA TRACTION TRANSFORMER

REF. No.	DESCRIPTION OF THE EQUIPMENT	MVA RATING OF TR. TRANS.	INCOMING SUPPLY			
			220kV	132kV	110kV	66kV
1	DP ISOLATOR	21.6	1250A 31.5kA	1250A 31.5kA	1250A 31.5kA	1250A 31.5kA
		13.5	—	630A 15kA	630A 15kA	1250A 31.5kA
2	CT	21.6	200-100/5A 30VA	400-200/5A 30VA	400-200/5A 30VA	800-400/5A 30VA
		13.5	—	200-100/5A 30VA	300-150/5A 30VA	400-200/5A 30VA
3	CB	21.6	1250A 31.5kA	1250A 31.5kA	1250A 31.5kA	1250A 31.5kA
		13.5	—	1250A 31.5kA	1250A 31.5kA	1250A 31.5kA
4	LA	21.6	198kV	120kV	96kV	60kV
		13.5	—	120kV	96kV	60kV
5	BUSHING CT (PRIMARY SIDE)	21.6	200/5A PS CLASS	330/5A PS CLASS	400/5A PS CLASS	660/5A PS CLASS
		13.5	—	200/5A PS CLASS	200/5A PS CLASS	400/5A PS CLASS
6	TRACTION (TRANSFORMER)	21.6	21.6MVA 220/27kV	21.6MVA 132/27kV	21.6MVA 110/27kV	21.6MVA 66/27kV
		13.5	—	13.5MVA 132/27kV	13.5MVA 110/27kV	13.5MVA 66/27kV
7	BUSHING CT (SECONDARY SIDE)	21.6	1600/5A	1600/5A	1600/5A	1600/5A
		13.5	—	1000/5A	1000/5A	1000/5A
8	PT(HT)	—	220//3kV	132//3kV	132//3kV	66//3kV
		—	110//3V	110//3V	110//3V	110//3V

## NOTES:-

- THIS DRAWING IS BASED ON TYPICAL LAYOUT OF 132/25kV TRACTION SUB-STATION WITH SINGLE TRANSFORMER DRG. No.ETI/PSI/025.
- THE NOMINAL RATING OF THE 220 OR 132 OR 110 OR 66/27kV TRACTION TRANSFORMER IS 21.6 OR 13.5MVA AT 27kV NO LOAD SECONDARY VOLTAGE, POWER FACTOR OF 0.8 LAGGING AND RATED SECONDARY CURRENT OF 800A OR 500A THE IMPEDANCE VOLTAGE OF TRANSFORMER IS 12% AT 21.6 OR 13.5MVA BASE.
- FOR PROTECTION SCHEME OF DOUBLE TRANSFORMER TRACTION SUB-STATION REFER DRAWING No.ETI/PSI/024-1.
- FOR PROTECTION SCHEME OF SHUNT CAPACITOR BAY WHEREVER PROVIDED, REFER DRAWING No.ETI/PSI/SK/343.

"THIS DRAWING IS THE PROPERTY OF RESEARCH, DESIGNS & STANDARDS ORGANISATION (MINISTRY OF RAILWAYS), LUCKNOW-226011, INDIA AND SHALL NOT BE USED, COPIED OR REPRODUCED, IN PART OR WHOLE, WITHOUT PRIOR CONSENT IN WRITING."

TYPICAL SCHEMATIC DIAGRAM OF PROTECTION FOR SINGLE TRANSFORMER TRACTION SUB-STATION		JD/TI	Sd/-
			22.4.94
		ADE/TI	Sd/-
			22.4.94
REF:-		CROSS REF:-	
DATE	MOD.	NATURE OF MOD.	
		INITIAL	R. D. S. O.
		DATE	NAME
		DR.	S.C.
		TC.	ETI/PSI/0228-1
		CK.	SCALE:- N.T.S
			SUB SCALE:-
			SUB SCALE:-
			REV. B