

## INDIAN RAILWAYS



### CHECK SHEETS

FOR

**BOGIE OPEN WAGON (91.6 Tonnes)**

**TYPE – BOXNHL-MBS (DESIGN-D)**

S.No.	Month & Year of issue	Revision / Amendment	Page No.	Reason for Amendment
1.	October, 2011	First issue	-	-

**ISSUED BY**

**RESEARCH DESIGNS AND STANDARDS ORGANISATION  
MINISTRY OF RAILWAYS  
LUCKNOW-226 011**

**October, 2011**

## CONTENTS

Sr. No.	Description	Page No
<b>Check sheets page</b>		
1.	Centre Sill	3
2.	Underframe	4
3.	Body End	5
4.	Body Side	6
5.	Flap Door	7
6.	Final Assembly	8
7.	BMBS Clearance in assembled wagon(Brake Released)	9
8.	Final Wagon	10
9.	Other attributes	11
10.	Performance for Single wagon air brake test	12-13

**Note:**

These check sheets do not detail all the dimensions or technical requirements of respective wagon assemblies/components.

These check sheets are issued only for General Guidance & assistance of inspecting officials. Notwithstanding the above, the inspecting officials are advised to refer to relevant drawings and/or relevant specifications to confirm conformity to the specified dimensions and technical details.

### Centre Sill

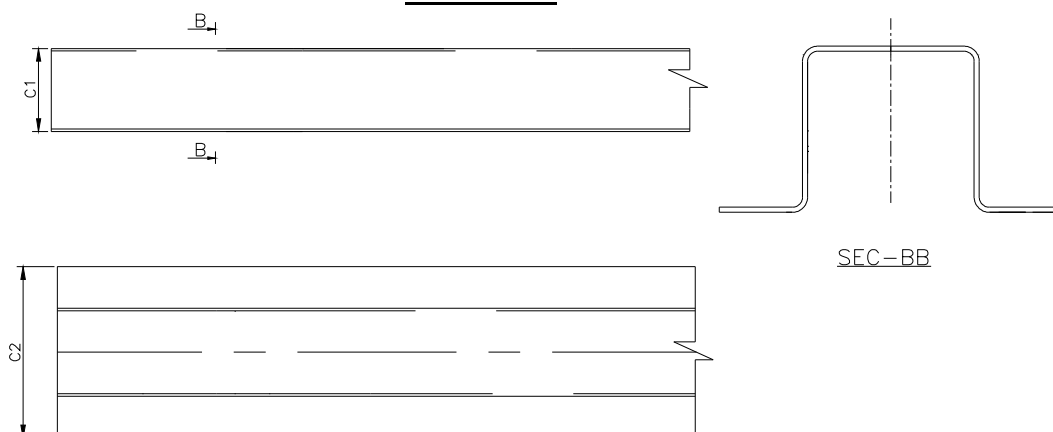

CENTRE SILL NO:			Date:			
SL. NO.	STAGE	Works Inspection		RDSO Inspection	Remarks	
1.	Centre Sill 'Hat' section.					
1.1	Fitment of all components					
1.2	Welding					
1.3	Dressing					
1.4	Lock Bolting					
2.	Dimensions			As follows		
	<b>LOCATION</b>		<b>Nominal Dimensions &amp; Allowable Deviation</b>	<b>Actual Dimension</b>		<b>Remarks</b>
				Works Inspection	RDSO Inspection	
i.	Length	A1	*10034, +7,-3			
		A2				
ii.	Height and width of Centre Sill	C1	327, ±1.5			
		C2	674, ±3			
iii.	Draft Gear Pocket	X	625.5, +0, -1.6			
		Y	327, +1.5, -0			

All dimensions are in mm

\*Final length (without considering contraction allowance)

Works Inspector		RDSO Inspector	
Signature:		Signature:	
Name:		Name:	
Designation:		Designation:	
Date:		Date:	

**UNDERFRAME**

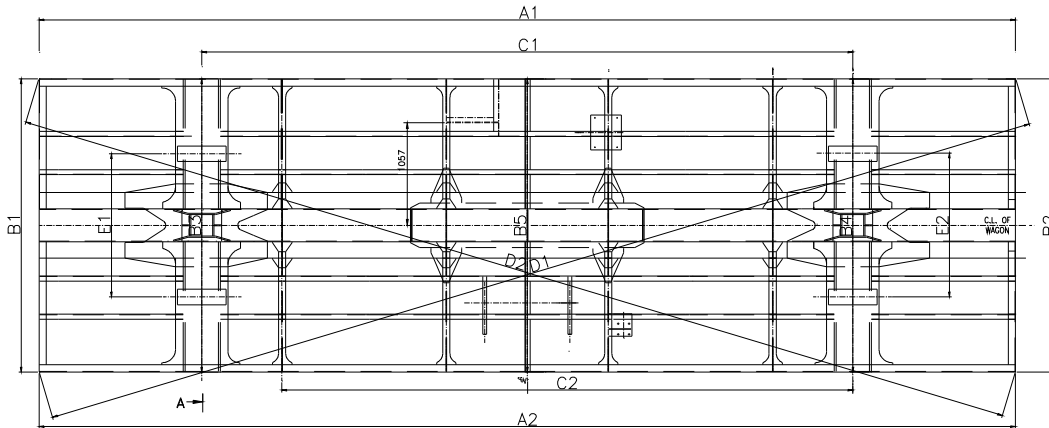

UNDERFRAME NO:		Date:				
SL. NO.	STAGE	Works Inspection		RDSO Inspection	REMARKS	
1.	Fitment of all components					
2.	Welding					
3.	Dressing					
4.	Dimensions	As follows				
	<b>LOCATION</b>		<b>Nominal Dimensions &amp; Allowable Deviation</b>	<b>Actual Dimension</b>		<b>Remarks</b>
				Works Inspection	RDSO Inspection	
i.	Length over head stock	A1 A2	10034, +7,-3			
ii.	Width over solebar	B1 B2 B3 B4 B5	3022±3			
iii.	Distance between bolster bogie centre	C1 C2	6690, +5,-2			
iv)	Distance between side bearers centre	E1 E2	1474±2			
v)	Diagonal difference over headstock	D1 D2	≤ 5			
vi)	Camber		*6±2			
vii)	Difference between side bearer top liner and center pivot top		9.5,+0,-0.5			

All dimensions are in mm  
 \*to be measured in final assembly

Works Inspector		RDSO Inspector	
Signature:		Signature:	
Name:		Name:	
Designation:		Designation:	
Date:		Date:	

**BODY END**

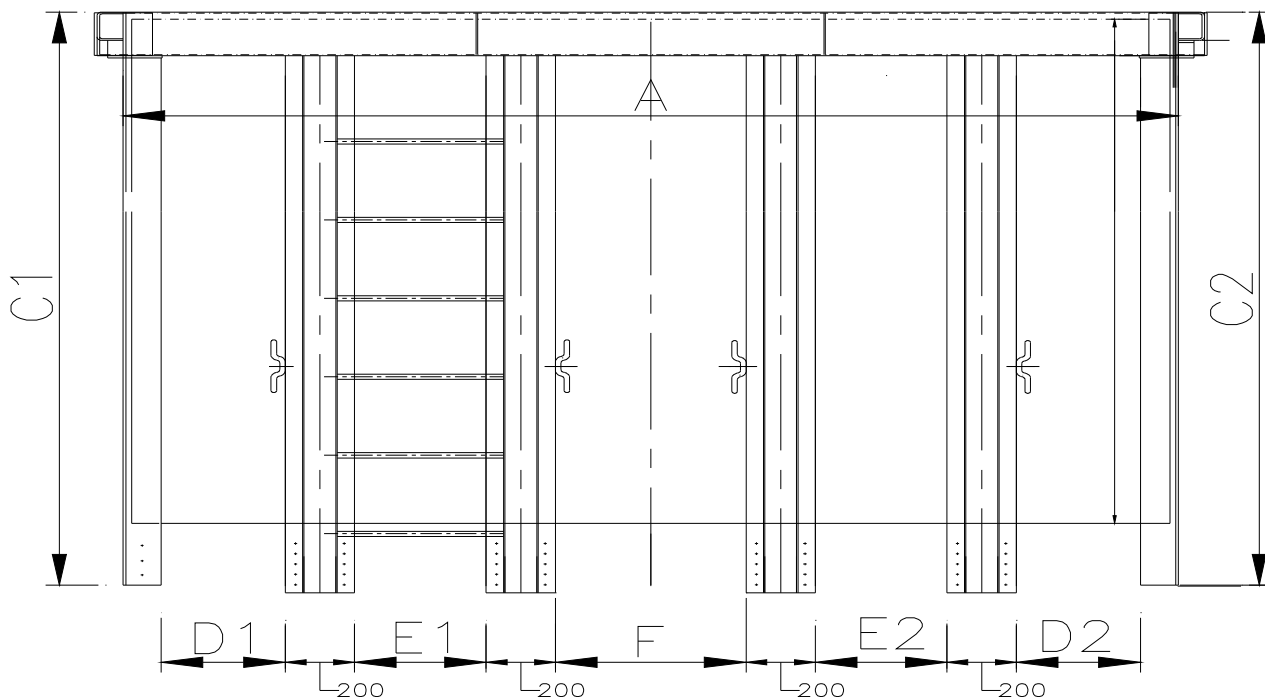

BODY END NO:		Date:				
SL. NO.	STAGE	Works Inspection	RDSO Inspection		Remarks	
1.	Fitment of all components					
2.	Welding					
3.	Dressing					
4.	Dimensions	As follows				
	LOCATION		Nominal Dimensions & Allowable Deviation	Actual Dimension		Remarks
				Works Inspection	RDSO Inspection	
i.	Width over corner stanchions	A	3046+3 -0			
ii.	End Wall overall height	C1	2232± 3			
		C2				
iii.	Distance between corner angle to outer stanchion	D1	358± 1.5			
		D2				
iv.	Distance between inner to outer stanchion	E1	380± 1.5			
		E2				
iii.	Distance between inner to inner stanchion	F	550± 1.5			

All dimensions are in mm

Works Inspector		RDSO Inspector	
Signature:		Signature:	
Name:		Name:	
Designation:		Designation:	
Date:		Date:	

**Body Side**

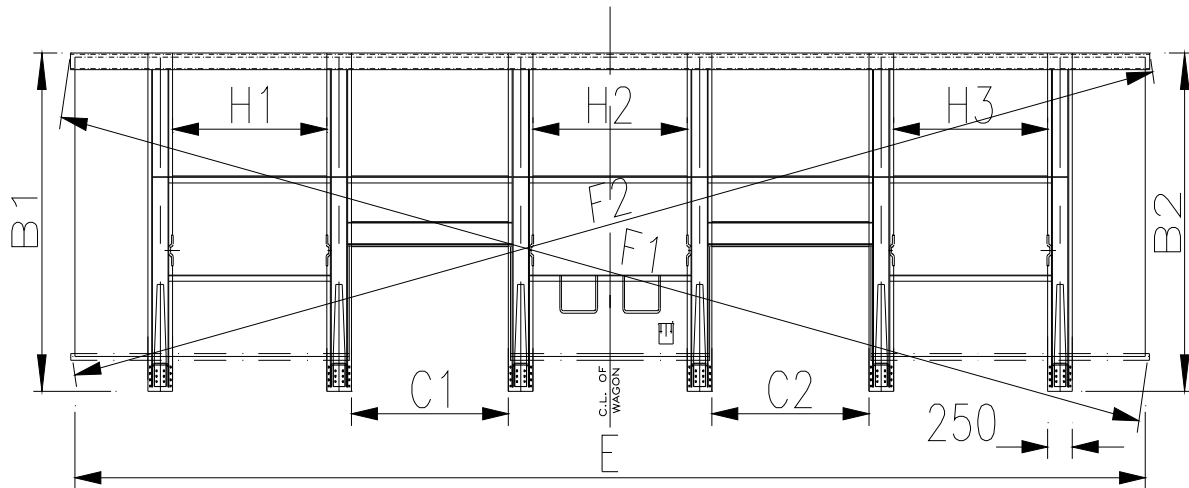

<b>BODY SIDE NO:</b>						
<b>Date:</b>						
SL. NO	STAGE	Works Inspection		RDSO Inspection	Remarks	
1.	Fitment of all components					
2.	Welding					
3.	Dressing					
4.	Dimensions			As follows		
	LOCATION	Nominal Dimensions & Allowable Deviation		Actual Dimension		Remarks
				Works Inspection	RDSO Inspection	
i.	Side Wall Overall Height	B1	2218±3			
		B2				
ii.	Door opening	C1	1440,+0,-3			
		C2				
iii.	Distance between side plate end to end	E	9958+7,-3			
iv.	Diagonal difference over corner	F1	≤ 5			
		F2				
v.	Distance between stanchion at dummy quarter	H1	1414± 3			
		H2				
		H3				

All dimensions are in mm

Works Inspector		RDSO Inspector	
Signature:		Signature:	
Name:		Name:	
Designation:		Designation:	
Date:		Date:	

**FLAP DOOR**

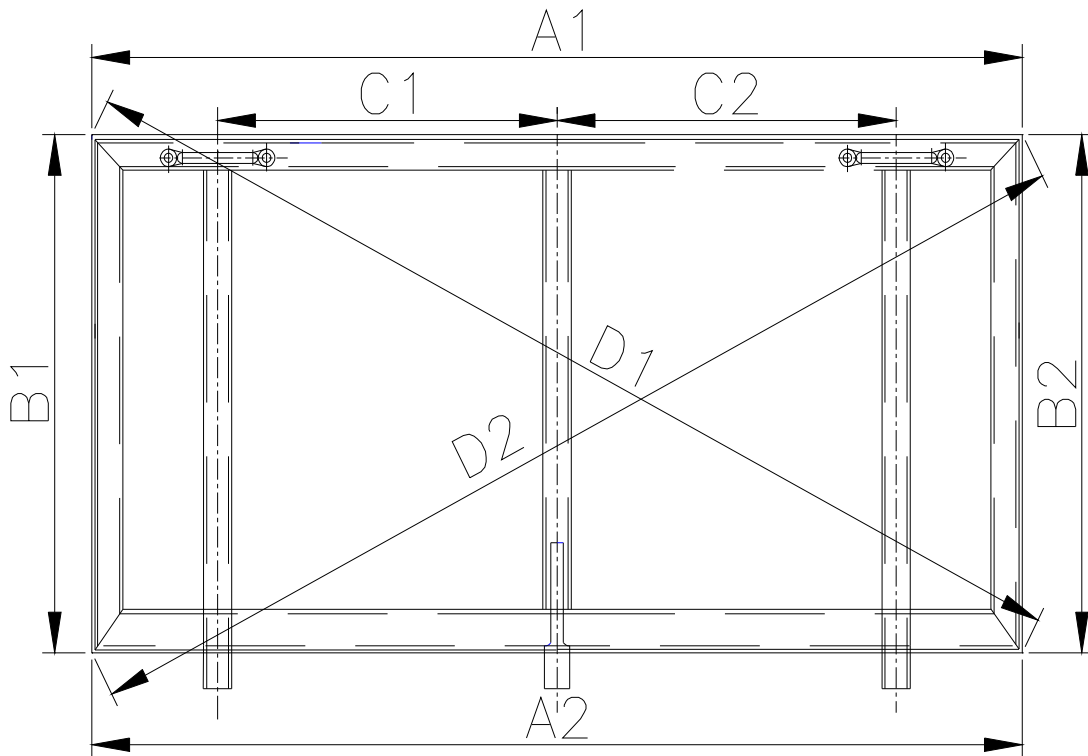

FLAP DOOR NO:			DATE:		
SL. NO.	STAGE	Works Inspection	RDSO Inspection		Remarks
1.	Fitment of all components				
2.	Welding				
3.	Dressing				
4.	Dimensions	As follows			
	LOCATION		Nominal Dimensions & Allowable Deviation		Actual Dimension
				Works Inspection	RDSO Inspection
					Remarks
i.	Length of flap door	A1	1460, +5,-0		
		A2			
ii.	Height of flap door	B1	775, +3,-0		
		B2			
iii.	Distance between door C.L to C.L of door hinge	C1	540±1.5		
		C2			
iv.	Diagonal difference over corner	D1	≤ 3		
		D2			

All dimensions are in mm

Works Inspector		RDSO Inspector	
Signature:		Signature:	
Name:		Name:	
Designation:		Designation:	
Date:		Date:	

**FINAL ASSEMBLY**

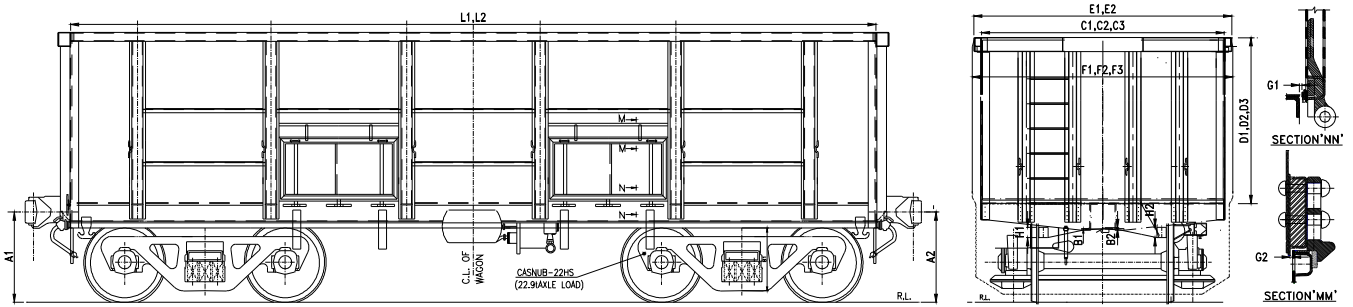

Wagon No.:		U/F No.:		Date:		
SL. NO.	STAGE	Works Inspection	RDSO Inspection	Remarks		
1.	Fitment of all components					
2.	Lock Bolting					
3.	Welding					
4.	Operation of Doors					
5.	Operation of Couplers					
6.	Under gear Examination					
7.	Brake test i) Air brake ii) Hand brake					
8.	Painting					
9.	Lettering					
10.	Dimensions	As follows				
	LOCATION		Nominal Dimensions & Allowable Deviation	Actual Dimension		Remarks
				Works Inspection	RDSO Inspection	
i.	Coupler height from R.L	A1	1105, +0, -5			
		A2				
ii.	Length Inside	L1	10034, +7, -3			
		L2				
iii.	Width Inside	C1	3022, ± 3			
		C2				
		C3				
iv.	Height Inside (Floor level to top)	D1	2028, ± 3			
		D2				
		D3				
v.	Width over end	E1	3212, ± 3			
		E2				
vi.	Centre pivot assembled height	B1	120, +2, -0			
		B2				
vii.	Side bearer set up height from bolster seat	H1	126.5, +0.5, -0			
		H2				
viii.	Overall Width	F1	3250, ± 3			
		F2				
		F3				
ix.	Clearance between floor plate & door packing	G1	5mm±0.5			
x.	Clearance between doorway crossbar & door plate	G2	5mm±0.5			

All dimensions are in mm

Works Inspector		RDSO Inspector	
Signature:		Signature:	
Name:		Name:	
Designation:		Designation:	
Date:		Date:	



**Check sheet for BMBS Clearance in assembled CASNUB Bogie  
(Brake in released condition)**

---

Wagon No.  
Bogie No.: (1)

Sr. No.	Description	Min Value in mm	Measured value.	
1.	Clearance between push rod and spring plank.	10	L	
			R	
2.	Total Clearance between bell crank levers and wheel faces ( i.e Total of left & right side)	80 Min. 20 (if measured on any one side.)	L	
			R	
			Total	
3.	Total Clearance (i.e sum of clearances) between 3.1 Spring plank & primary brake beam and 3.2 Spring plank & secondary brake beam.	77	L	
			R	
			Total	
4.	Clearance between brake cylinder & brake beam.	30		

Bogie No.(2)

Sr. No.	Description	Min Value in mm	Measured value.	
1.	Clearance between push rod and spring plank.	10	L	
			R	
2.	Total Clearance between bell crank levers and wheel faces ( i.e Total of left & right side)	80 Min. 20 (if measured on any one side.)	L	
			R	
			Total	
3.	Total Clearance (i.e sum of clearances) between 3.1 Spring plank & primary brake beam and 3.2 Spring plank & secondary brake beam.	77	L	
			R	
			Total	
4.	Clearance between brake cylinder & brake beam.	30		

Works Inspector		RDSO Inspector	
Signature:		Signature:	
Name:		Name:	
Designation:		Designation:	
Date:		Date:	

**FINAL WAGON**

1.	Wagon No.		2.	Date of offer	
3.	Underframe No.		4.	Name of the Wagon Manufacturer:	
5.	Contract/P.O. placed by		6.	Contract/P.O. No. and date and D.P. (Upto)	
7.	Running Gear				
a)	Bearing Make			Serial Nos.	
b)	Wheel Make			Serial Nos.	
c)	Axle Make			Serial Nos.	
d)	Bogie Make & Sr. Nos.		e)	Air Brake Make	
f)	DV Make & Sr. no.		g)	Date of air brake testing	
h)	Date of SWTR calibration		i)	Coupler Make & Sr. Nos.	
8.	Draft Gear Make, Model & Sr. Nos.		9.	Tare Weight	
10.	CRF section make		11.	Lock Bolt Make	
12.	Paint Make		13.	D.M. Issue date	
14.	TXR fit memo issue date		15.	CBB make & Sr. Nos.	
16	Brake Cylinder Make & Sr. Nos.				

14. RAD availed \_\_\_\_\_

15. Defects Observed \_\_\_\_\_

Works Inspector		RDSO Inspector	
Signature:		Signature:	
Name:		Name:	
Designation:		Designation:	
Date:		Date:	

## Other attributes

Wagon No.:		U/F No.:	Date:	
SL NO.	ATTRIBUTES	ACCEPTANCE LIMIT	WORKS INSPN.	RDSO INSPN.
1.	Check paint- for thickness & finish	Stainless Steel 130 microns after primer and 210 microns after finish paint. Paint surface to be free from blistering & peeling		
2.	Lettering & marking- for legibility, size, location & punch mark.	As per Drg No.WD-08008-S-21		
<b>3.</b>	<b>COUPLER</b>			
3.1	Height from Rail Level	1105 +0, - 5		
3.2	Operation of knuckle with operating handle	Full knuckle throw lock to lock		
3.3	Articulation of coupler body	Free movement		
<b>4.</b>	<b>HAND BRAKE</b>			
4.1	Apply hand brake (by one person only and strike all wheels with a Hammer)	There should not be ringing sound		
4.2	Release the hand brake and apply crow bar on one end of brake block to take up all slack	All brake blocks must be released. Gap between the brake block and wheel tread not to be less than 23.6 mm (5.9 x 4) -		

Works Inspector		RDSO Inspector	
Signature:		Signature:	
Name:		Name:	
Designation:		Designation:	
Date:		Date:	

**PROFORMA FOR SINGLE WAGON AIR BRAKE TEST**

Wagon No..... Bogie Make.....DV Make.....

S.No.	Check	Specified	Actual
1	Pressure in BP	$5 \pm 0.1$ kg/sq.cm.	
1.a	Pressure in FP	$6 \pm 0.1$ kg/sq.cm. ( twin pipe)	
2	Pressure in AR	$5 \pm 0.1$ kg/sq.cm.(for single pipe) $6 \pm 0.1$ kg/sq.cm. (for twin pipe)	
3	Leakage from the system in one minute.	0.1 kg/sq. cm.(max.)	
4	Full service application after charging		
4.1	Brake cylinder filling time a) Empty (Pressure rise from 0 to 2.1 kg/sq.cm.)  b) Loaded (Pressure rise from 0 to 3.6 kg/sq.cm.)	18 to 30 sec  18 to 30 sec.	
4.2	Maximum brake cylinder pressure a) Empty b) Loaded	$2.2 \pm 0.25$ kg/sq.cm. $3.8 \pm 0.1$ kg/sq.cm.	
4.3	Reduction in BP pressure required for full service application.	1.3 to 1.6 kg/sq.cm.	
5	Release after full service application.		
5.1	Draining time (Brake cylinder pressure to fall from $2.2 \pm 0.25$ kg/sq.cm. to 0.4kg/sq.cm.in empty condition & $3.8 \pm 0.1$ kg/sq.cm to 0.4 kg/sq.cm in loaded condition) a) Empty b) Loaded	45 to 60 sec 45 to 60 sec.	
6	Sensitivity of brakes. Isolate brake pipes from mainline. Check the response of brakes when brake pipe pressure is reduced at the most equal to 0.6 kg/sq.cm. in 6 sec.	Brake should apply within 6 sec.	
7	Insensitivity of brakes, isolate brake pipe from mainline. Check the pressure of brakes when brake pipe pressure is reduced at least equal to 0.3 kg/sq.cm. in 60 sec.	Brake should not apply	
8	Emergency application:		
8.1	Brake cylinder filling time a) Empty (Pressure rise from 0 to 2.1 kg/sq.cm.)  b) Loaded (Pressure rise from 0 to 3.6 kg/sq.cm.)	18 to 30 sec.  18 to 30 sec.	
8.2	Maximum brake cylinder pressure a) Empty b) Loaded	$2.2 \pm 0.25$ kg/sq.cm. $3.8 \pm 0.1$ kg/sq.cm.	
9	Piston stroke  Empty Condition *	$54 \pm 10$ mm	
10	Leakage from brake cylinder after emergency application.	0.1 kg/sq.cm. (max.) within 5 minutes	

11	Automatic exhausting of brake cylinder and control chamber.		
11.1	Apply emergency brakes (i.e. BP=0kg/sq.cm). Check the brake cylinder pressure after giving a brief pull to release hook.	Brake cylinder and control reservoirs should exhaust automatically.	
12	Empty load change over by APM Device		
12.1	Unrestricted movement of lever arm APM Device.	Brake cylinder pressure $2.2 \pm 0.25$ kg/sq.cm.	
12.2	Restrict the movement of lever arm of APM Device by more than 25 mm (by putting a block of 25 mm thickness) from its initial position.	Brake cylinder pressure $3.8 \pm 0.1$ kg/cm <sup>2</sup>	
13	Hand Brake		
13.1	Apply hand brakes(by one person only and strike all wheels with hammer)	There should not be ringing sound	

14.	AR Charging time (Pressure rise from 0 to 5.0 kg/sq.cm.)	175 $\pm$ 30 Sec for C3W D.V	
		60 to 120 Sec for KEO D.V	
15.	CR Charging time (Pressure rise from 0 to 4.8 kg/sq.cm.)	165 $\pm$ 20 Sec for C3W D.V	
		160 to 210 Sec for KEO D.V	

\* However, if in a few cases, the piston stroke at empty pressure during testing on SWTR exceeds the specified range, the piston stroke is to be tested by locking the wheels with wedges.

S.No. 14 and 15 to be checked at the time of prototype Wagon only

Works Inspector		RDSO Inspector	
Signature:		Signature:	
Name:		Name:	
Designation:		Designation:	
Date:		Date:	