



No. SV.ICF

Dated : 01.09.2009

The General Manager (Engineering),

- i. Western Railway, Churchgate, Mumbai-400020
- ii. Central Railway, CSTM, Mumbai - 400 001
- iii. Eastern Railway, Fairly Place, Kolkata- 700 001
- iv. Southern Railway, Park Town, Chennai - 600 003

Sub:- Final Speed Certificate for operation of BG ICF AC-DC EMU Motor and Trailer coaches fitted with modified ICF bogies having Hydro-springs with internal damping at primary stage and pneumatic suspension at the Secondary Stage at a speed of 105 kmph on track maintained to other than C&M-I Vol-I standards.

1. The primary suspension of EMU stock at present consists of coil springs with dashpot oil arrangement. The secondary suspension has been improved substantially by the introduction of air springs to cater to the high payloads typical to EMU services. With the objective of improving the suspension further, designs that eliminate the dashpot arrangement at the primary stage have been evaluated at RDSO. The bogie general arrangement with Hydro-springs at primary suspension is based on ICF drg.no. AC/DC EMU/M7-0-0-701 for Motor Coach and AC/DC EMU/D6-0-0-601 for Trailer Coach.
 - 1.1 Detailed oscillation trials were conducted upto a maximum speed of 115 kmph in empty and loaded condition over CCG-VR section of Western Railway. Results of these tests as contained in report no. RDSO/TG/MT-967/F Rev.0 Dt.15.07.2009 indicate acceptable riding behaviour of test coach in empty and loaded condition upto a maximum speed of 115 kmph.
2. Based on the above, it is certified that AC-DC EMU Motor and Trailer coaches are fit for operation upto maximum speed of 105 kmph over track laid down to standards other than those specified in C&M-I, Vol.I, of Indian Railways subject to conditions given below.
 - 2.1 **Track**
 - 2.1.1 (a) Speed upto 105 kmph

The track shall be to a minimum standard of 52 kg rails (90TS) on sleepers to M+7 density and minimum depth of ballast cushion below sleepers of 250 mm which may consist of at least 100 mm clean and the rest in caked up condition, on compacted and stable formation.
 - (b) Speed upto 70 kmph

The track shall be to a minimum standard of 52 kg rails (72TS) on sleepers to M+7 density and minimum depth of ballast cushion below sleepers of 250 mm which may consist of at least 100 mm clean and the rest in caked up condition, on compacted and stable formation.

- 2.1.2 For track maintained to lower standard than that mentioned above, the Chief Engineer shall decide the lower maximum permissible speed on the basis of maintenance condition. In this connection, Railway Board's letter No. 65/WDO/SR/26 dated 19/20-10-1966 may be seen. When the Chief Engineer considers that the road bed is not compacted or there is improper drainage, he may suitably restrict the maximum permissible speed depending upon the local conditions.
- 2.1.3 The maximum permissible speed on curves to be decided on the basis of existing provision of the Indian Railway Permanent Way Manual, second reprint 2004.

2.2 Bridges

- 2.2.1 The clearance refers to bridges with standard design of girders, slabs, pipe culverts, piers and abutments etc. issued by RDSO for BGML, RBG and MBG-1987 standard loadings. However, the bearings of span 78.8m (effective) designed for BGML standard loading as per RDSO's drawing no.BA-11154 should be strengthened by providing two additional anchor bolts.
- 2.2.2 Superstructures & bearings of non-standard spans including Arches and sub-structures of all bridges are to be examined under the directions of the Chief Bridge engineer concern and certified safe by him in terms of current IRS Bridge Rules, Steel Bridge Code, Concrete Bridge Code, Arch Bridge Code, Bridge Sub-Structures and Foundation Code etc. read with upto date correction slips.
- 2.2.3 Zonal Railways to certify the adequacy of existing bridges for permitting rolling stocks based on physical condition of bridges by keeping them under observations considered necessary the Chief Bridge Engineer of Railway.
- 2.2.4 Location of bridges on which speed restrictions are imposed shall be notified by the Railways and incorporated in the working time table.
- 2.2.5 The clearance is subject to the following parameters of AC-DC EMU Coach :-

Parameters	MC	TC
(i) Maximum axle load (Design)	20.32 t	20.32 t
(ii) Maximum Tractive effort (MC)	13.76 t	---
(iii) Max. Braking force at Rail Level	5.116t	3.82t
(iv) Max. C.G. Height from Rail Level	Not to exceed 1830mm	

2.3 Signaling

- 2.3.1 Provisions of GR, SR, SEM & all extant instructions issued from time to time shall be complied with.
- 2.3.2 On the sections where EBD of more than 1 km is to be catered for, second distant signal or automatic signaling should be available failing which suitable speed restriction is to be imposed.

2.4 Traction Installation

- 2.4.1 The OHE shall have swiveling type of cantilever having the tension in the conductors regulated automatically with a presag of 50/100 mm. The presag is on the contact wire for a span of 72m, proportionately less for smaller spans.

- 2.4.2 In case of locations where porcelain section insulators are installed on main line and lie within first 1/10th and 1/3rd of the span immediately after the OHE structure and the runners are in the trailing direction, the maximum speed shall be 120 kmph. At all other locations where porcelain section insulators are installed, the speed shall be limited to 80 kmph.
- 2.4.3 In 25 kV a.c. traction area, the CEE of Railway shall have to ensure that the minimum height of contact wire as stipulated in provision of Chapter-V and V-A, Electric Traction "Schedule of Dimension of 1676 gauge (BG) revised 2004" is not violated and strictly followed to ensure its safe running.
- 2.4.4 In addition to the above, the Chief Electrical Engineer may impose any temporary speed restrictions on the basis of his personal knowledge and experience of the OHE and the conditions prevailing on the particular section.
- 2.4.5 For DC OHE the condition of operation shall be specified by CEE of the concerned railway.

2.5 Rolling Stock

- 2.5.1 Before initiating the operation the above stock, CME of the concerned Railway will certify the track worthiness and safety of the rolling stocks. He will also ensure proper maintenance of the rolling stock.

2.6 General

- 2.6.1 All the permanent and temporary speed restrictions in force and those that may be imposed from time to time due to track, bridges, curves, signaling and interlocking etc. shall be observed.
- 2.6.2 The profile of AC-DC EMU fitted with Hydro-springs at primary stage and pneumatic suspension at secondary is identical to that of existing ICF coaches. There is no infringement with the provisions of IRSOD(BG), Revised 2004.

Encl.: ICF's drawing no. 1. AC/DC EMU/M7-0-0-701
2. AC/DC EMU/D6-0-0-601



(S. Mani)

Executive Director Standards (Motive Power)

Copy:-

1. **The Secretary (Mech./Engg.), Railway Board, Rail Bhawan, New Delhi-110001**
2. **The General Manager (Mech/ Optg. /Elec./ S&T)**
 - i. Western Railway, Churchgate, Mumbai-400020
 - ii. Central Railway, CSTM, Mumbai - 400 001
 - iii. Eastern Railway, Fairly Place, Kolkata- 700 001
 - iv. Southern Railway, Park Town, Chennai - 600 003



(S. Mani)

Executive Director Standards (Motive Power)

AC/DC/EMU/M-0-0-701

- BRUSH MOUNTED
- VEE FINISH MACHINED
- VVV FINE FINISH MACHINED
- BUSHES CLAMPED
- CHAMFERED
- BURRS REMOVED

ALTERATION

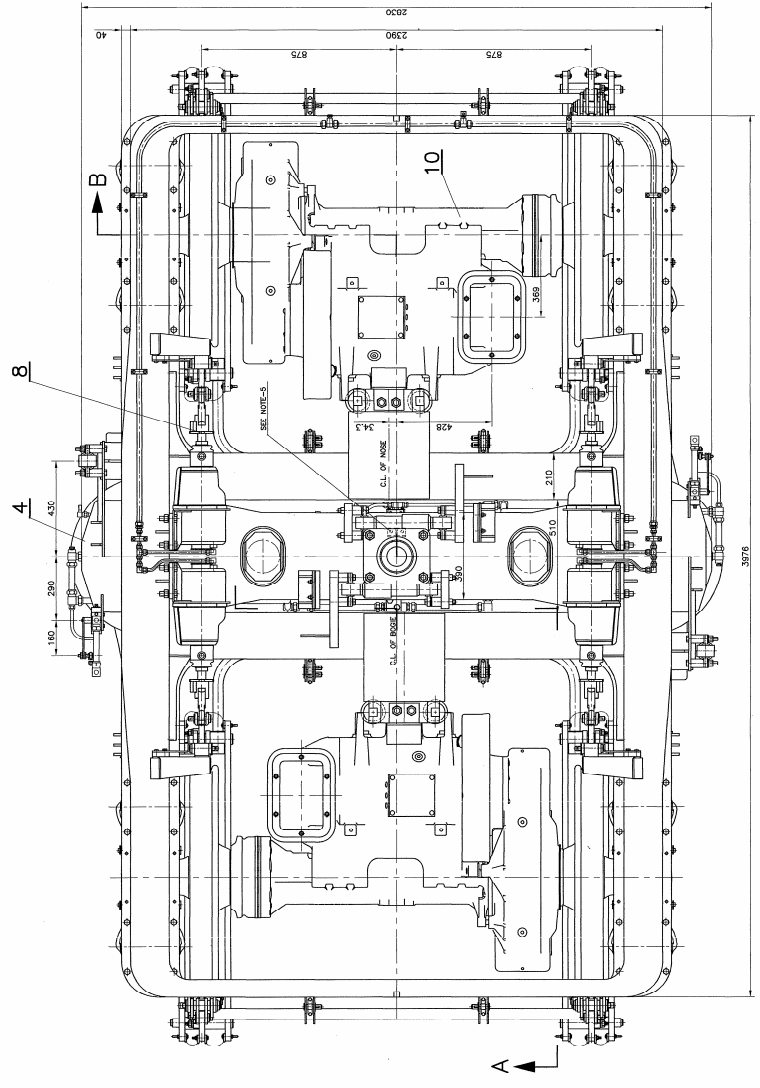
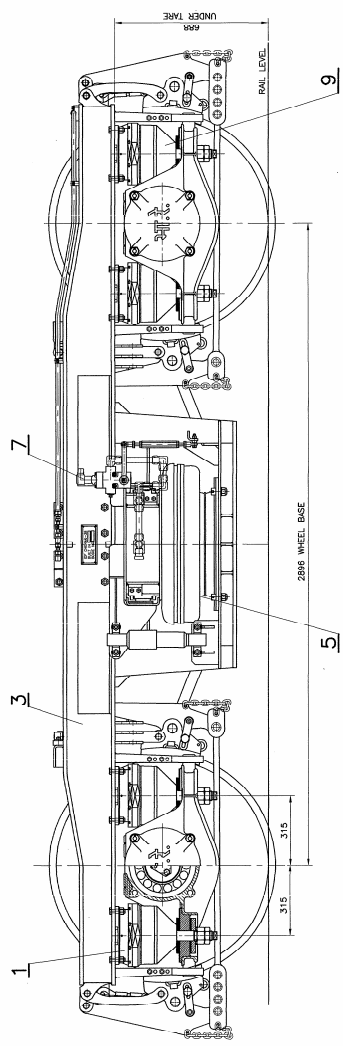

NO. DEF.	DESCRIPTION & DIMENSIONS	TD	REF. DRG.	MTY. & SPEC.	WEIGHT/UNIT	REMARKS
IV	GROUP - BOGIE GENERAL ARRGT. (0-0)					
	BOGIE GENERAL ARRGT. WITH HYDROSPRING IN PRIMARY SUSPENSION FOR MVIC MOTOR COACHES					
	CAD FILE - S:\M0-200\338\0-0\01\540.dwg					
	CODE NO.					
	338					
	INDIAN RAILWAY STANDARDS					
	SHEET 1 OF 2					
	AC/DC/EMU/M-0-0-701					

ASSEMBLY DRAWINGS	DATE OF ISSUE	REV. NO.	DATE OF REV. DATE
11-10-2004	0	0	0
11-11-04	1	1	0

FORM R AT 840 X 600

AC/DC/EMU/D₆-0-601

▽	ROUGH MACHINED	⊕	ROUGH CLEANED
▽▽	FRESH MACHINED	⊕	CHAMFERED
▽▽▽	FINE FINISH MACHINED	⊕	BURRS REMOVED

ALTERATION

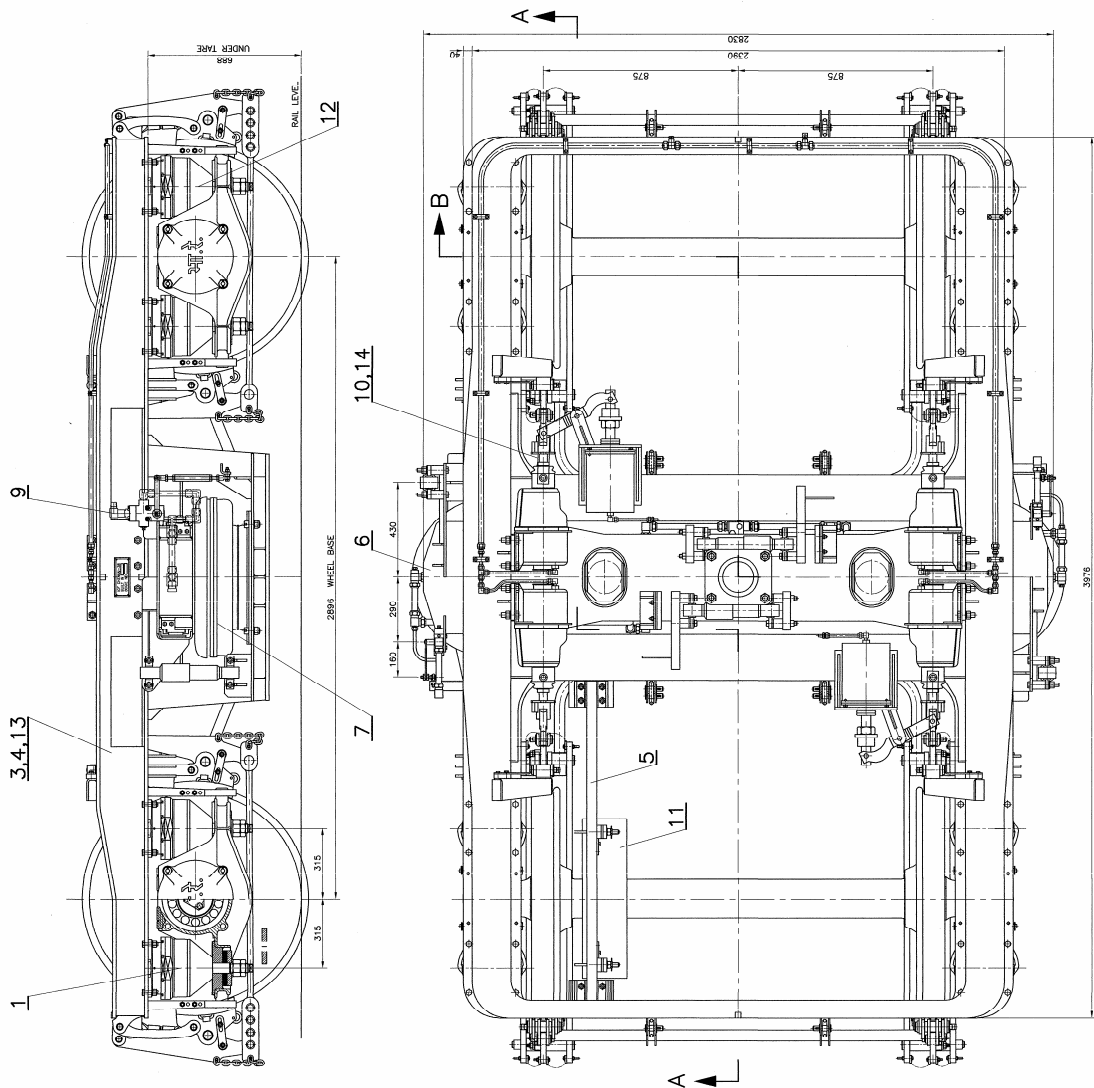

NO. OF T.	DESCRIPTION & DIMENSIONS	ITEM REF. DR.	MAT. & SPEC.	WEIGHT/UNIT	REMARKS
1	GROUP - BOGIE GENERAL ASSEMBLY (0-0)				
<p align="center">BOGIE GENERAL ASSEMBLY WITH HYDROSPRING IN PRIMARY SUSPENSION FOR MRVC TRAILER COACHES</p>					
<p>CALL FILE - C:\IND-CON\3390-0\BGT1500.dwg</p>					
<p>CODE NO. 339 INDIAN RAILWAY STANDARDS</p>					
<p>AC/DC/EMU/D₆-0-601</p>					

ASSEMBLY DRAWINGS 17-10-2005 DATE OF FIRST ISSUE AAE/D	SHEET NO. 339 OF 3 AC/DC/EMU/D ₆ -0-601
---	--