

SPECIFICATION NUMBER: TI/SPC/OHE/MCS/0150(08/2015)

Rev.1



**GOVERNMENT OF INDIA
MINISTRY OF RAILWAYS**

**PERFORMANCE SPECIFICATION
FOR
MODULAR CANTILEVER SYSTEM (MCS)
FOR
25 KV AC TRACTION**

(For official use only)

ISSUED BY

**TRACTION INSTALLATION DIRECTORATE
RESEARCH DESIGN AND STANDARDS ORGANISATION
MANAK NAGAR, LUCKNOW 226 011
(INDIA)**

INDEX

ITEM NO.	HEADING	PAGE
1.0	SCOPE	3
2.0	GOVERNING SPECIFICATIONS	3-4
3.0	ENVIRONMENTAL REQUIREMENTS	4
4.0	GENERAL & TECHNICAL REQUIREMENT	5-6
5.0	INSPECTION & TESTING	7-8
6.0	TEST METHODS	8
7.0	CRITERIA FOR ACCEPTANCE OF FINISHED PRODUCT	8
8.0	PACKING AND MARKING	9
9.0	INSTALLATION, COMMISSIONING & TRIAL	9
10.0	RELIABILITY	9
11.0	MAINTAINABILITY	9
12.0	WARRANTY	9
-	ANNEXURE-I : CONTACT WIRE PROFILE	11
-	ANNEXURE-II: EXISTING CANTILIVER ASSEMBLY	12
-	ANNEXURE-III: DETAILS OF EXISTING CANTILEVER ASSEMBLY vis-à-vis MODULAR CANTILEVER SYSTEM COMPONENTS	13
-	ANNEXURE-IV: PERFORMANCE REPORT OF MODULAR CANTILEVER SYSTEM(MCS)	14
-	ANNEXURE-V: BOW PROFILE OF THE PANTO PAN	15
-	PANTO PAN PROFILE OF 2030mm WIDE BOW	16

PERFORMANCE SPECIFICATION
FOR MODULAR CANTILEVER SYSTEM (MCS) FOR 25 kV A.C. OVER HEAD
TRACTION SYSTEM

1.0 SCOPE:

1.1 In 25kV Over Head Traction System, bracket assembly supports both the main conductors and is more or less pivoted to the structures, capable of swiveling along the track as well as adjustable in transverse direction. This assembly holds the following OHE configurations: -

- a) Type- I: OHE configuration of 65 mm² catenary wire & 107mm² contact wire with maximum tension of 1200 kgf in each conductor (catenary wire/contact wire).
- (b) Type- II: OHE configuration of 125 mm² catenary wire & 150 mm² contact wire with maximum tension of 1500kgf in each conductor (catenary wire/contact wire).
- (c) Type- III: OHE configuration of 125 mm² catenary wire & 193mm² contact wire with maximum tension of 1500 kgf in each conductor (catenary wire/contact wire).

Hard drawn Copper Contact wire (~~1000~~/1200/1500 kgf tension) in simple polygonal design (drawings attached as Annexure -I). A schematic diagram of bracket assembly is placed at Annexure-II.

1.2 This specification covers the requirement of "Modular Cantilever System" (henceforth referred as MCS) to suit the foot print dimensions on OHE masts/portals and insulators that exists on Indian Railway's 25kV ac traction network. Details of existing cantilever assembly components viz-a-viz Modular Cantilever System components are given in Annexure-III.

1.3 MCS shall consist of cantilever, suitable mast attachment fittings, 25kV bracket & stay insulators, catenary wire suspension system, steady arm and other components & assemblies essentially required to support the overhead conductors for smooth current collection, without hard spots.

1.4 This specification covers the requirement of field trials of MCS on the nominated section of Indian Railways at a maximum speed for that section for six months period. The device shall be put for field trials, to observe its performance. Data shall be recorded in the format enclosed at Annexure-IV to help in taking decision regarding adoption of type of Modular Cantilever System suitable for Indian Railways.

1.5 Modular Cantilever System shall be Light Weight and capable for use with train speed up to 200 kmph.

1.6 As the requirements are defined for development of the Modular Cantilever System, better specification/parameters may be accepted for trial/testing by Indian Railways. Deviation in the specified parameters may also be considered by Indian Railways on merit and mutual agreement basis. However, manufacturers must note that once the product is developed and stabilized, Indian Railways reserve the right to freeze/ standardize any particular design or may provide its own design which shall be binding on all the manufacturers.

2.0 GOVERNING SPECIFICATIONS: In preparation of this specification, reference has been made to the following specification:

1.	IS : 1285-2002	Specification for wrought aluminium and aluminium alloys, extruded round tube and hollow sections (of general engineering purposes) .
2.	IS : 2673-2002	Specification for Dimensions for wrought aluminium and aluminium alloys , extruded tube (round) .
3.	IS:4711-2008	Methods for sampling of pipes, tubes and fittings.
4.	IS :504-1963	Methods of Chemical Analysis and its alloy
5.	IS:1608-2005	Mechanical Testing of Metals-Tensile Testing
6.	IS:5052-1993	Aluminium & its Alloy - Temper Designation
7.	IS: 6051-1970	Code for Designation of Aluminium & its Alloy
8.	ASTM B221M	Standard Specification for Aluminum-Alloy Extruded Bar, Rod, wire, Profiles and Tube (Metric)
9.	ASTM B317/B317M - 07	Standard Specification for Aluminum-Alloy Extruded Bar, Rod, Tube, Pipe, Structural Profiles, and Profiles for Electrical Purposes (Bus Conductor)
10.	ASTM B557	Tension testing of wrought and cast aluminum & magnesium alloy products
11.	ASTM E-155-00 (2005)/DIN EN VDE 0216	Reference for Radiographs for inspection of Aluminum & Magnesium castings.
12.	TI/SPC/OHE/INS /0070	Specification for solid core porcelain insulators for 25kV, a.c. 50Hz Over head traction lines.
13.	TI/SPC/OHE/INS COM/1071	Specification for composite insulator for 25kV, a.c. 50Hz Overhead tractionlines.
14.	TI/SPC/OHE/FA STNERS/0120 (Rev.01)	Specification for Steel Fasteners & Stainless Steel Fasteners for25 kV A.C. Traction Overhead Equipment
15.	TI/SPC/OHE/ FITTINGS/0130	Technical specification for 25 kV AC OHE Fittings
16.	EN 12165/ ASTM B124	Specification for Copper and Copper Alloy Forging Rod, Bar & Shapes
17.	EN 1706/ASTM B 85	Specification for Aluminium Alloy Die Castings

2.1 The latest version of the abovementioned Specifications shall be available with the firm.

2.2 Any special requirements given in the relevant drawings submitted by manufacturer & approved by RDSO will override the specification.

3.0 ENVIRONMENTAL REQUIREMENTS: The MCS shall be used in varying atmospheric and climatic conditions as tabulated below.

i)	Ambient air temperature	0°C to (+)65°C
ii)	Maximum temperature of metallic object in Sun.	70°C
iii)	Minimum Temperature	(-) 10°C
iii)	Maximum relative humidity	100%
iv)	Annual rainfall	Dry Arid regions and also heavy monsoon affected regions with rainfall ranging from 1750 to 6250 mm
v)	Maximum number of Thunder storm days per /annum	85

vi)	Maximum number of Dust storm days per annum	35
vii)	Number of Rainy days per annum.	120
viii)	Basic wind pressure	216 kgf/m ²
ix)	Altitude	1000m/above 1000m height from sea level. Note -The Electrical Parameters above 1000 meter altitude are increased due to changes in Environmental conditions with change in altitude. Therefore, for higher altitude, Insulators shall be designed considering altitude correction factor for Electrical parameters in line with the stipulations given in IEC: 60071-2.
x)	Corrosion	Heavy corrosion prone areas, saline environment

4.0 GENERAL & TECHNICAL REQUIREMENTS:

4.1 The system offered shall be based on proven design. The manufacturer shall submit following design, drawings and design safety calculation for scrutiny & approval of RDSO. The manufacturer shall also submit Photographs, Precautions for handling, storage & installation of MCS, product catalogue, maintenance and service manual etc.

4.1.1 Drawings:

MCS (Plan & Elevation) including Stay & Bracket (Porcelain or Composite) Insulators, Mast & Portal attachment, Bent steady Arm and associated fittings & fasteners. Detailed dimensional drawing of each part and component.

4.1.2 Design:

- (i) Design safety calculations details with any of the following method:
1. Conventional method as per adopted by Indian Railway for existing cantilever made by galvanized steel tubes as per IS: 800-2007 (or latest).
 2. FEA analysis by validated software should be submitted. The design should be approved/ validated by any government Institution/University /Engineering college .

(ii) Manufacturer shall submit the Internal test report of tests carried out on MCS along with the offer.

Note (a): Each drawing shall carry the tabulation for item reference, item's name, drawing number, material grade, material specification, test specification, quantity & weight.

Note (b): Salient technical particulars of the assembly/components shall also be mentioned in the respective drawings.

Technical Literature & Other Details:

- (i) Manufacturer shall submit the Product Catalogue, Handling, Storage & Installation Instructions for MCS and Maintenance & Service Manual.
- (ii) Manufacturer shall submit the Tabulation Sheet for weight of MCS.

SN	Part name	Part no	Quarterly	Weight of each part	Total weight

4.2 After all the drawings and design documents are approved, the manufacturer shall submit two Reproducible Tracing Films (RTF) in standard size of 210mm x 297 mm or multiples of this for signature of approving authority. Only after all the design and drawings have been approved and clearance given by purchaser/

RDSO to this effect, the manufacturer shall take up manufacture of the prototype for RDSO's inspection. It is to be clearly understood that any changes required to be done in the prototype as required by RDSO shall be done expeditiously.

- 4.3** All fittings and fasteners shall be suitable for connection to the existing OHE mast and portals. Details of interfacing between OHE mast and cantilever assembly will be as per following details:

SN.	Drawing No.	Drawing Detail
1.	ETI/OHE/G/00144 Sh-3 (Mod C)	Standard Drilling Schedule of OHE mast 9.5 m long RSJ & BFB

- 4.4** Modular Cantilever System shall be suitable for maximum span length of 72meter.
- 4.5** All components of MCS shall be freely inter-changeable between various types of assemblies.
- 4.6** MCS shall be able to take vibrations due to wind and passage of trains and at times to impact loading in case of breakage of OHE conductors/Insulators during their life span.
- 4.7** The MCS shall be suitable for maximum tension length 1500 m of overhead equipment. An anti-creep is provided at middle of the tension length.
- 4.8** MCS shall be corrosion resistant to withstand the polluting & corrosive atmosphere such as in the coastal areas, in the vicinity of chemical plants and diesel loco sheds etc. Material specification should fulfill these requirements.
- 4.9** Manufacturer's monogram and Identification Number shall be engraved on parts of MCS as per the relevant drawings.
- 4.10** INTERFACE/MODULARITY OF THE SYSTEM: The MCS must fulfill the following essential requirements:
- Both stay & bracket insulators shall be attached to the mast with the same type of fitting.
 - It shall be possible to have different types of bracket assembly to suit the OHE design (for implantation in the range 2.36 m to 3.6 m) by changing minimal number of parts.
 - Types of tube fittings will be minimum.
 - Types of fasteners will be minimum.
 - Assembly, fixing, replacement will be easier and faster.
 - Maintenance check points will be least.
 - Maintenance periodicity will be higher.
 - Modular Cantilever Assembly shall be designed to have minimum number of components.

4.12 MATERIALS SPECIFICATION:

- Material of MCS items shall be as specified in Annexure-III.
- Stay Tube, Bracket Tube, Register Arm Tube and Bent Steady Arm shall fulfill design requirements. The tube shall be of the size such that the ratio of combined bending & axial stresses shall be <1.

Following details shall be submitted by the manufacture along with the loading diagram, calculation for permissible stresses and values of actual stresses as well as reference of standard, grade proposed to be used for manufacturing of components

of MCS.

SN	Parameters	Stay Tube	Bracket Tube	Register Arm	Bent Steady Arm
1	Nominal Diameter(mm)				
2	Outside Diameter(mm)				
3	Inside Diameter (mm)				
4	Thickness(mm)				
5	Mass (kg/m)				
6	Area of cross section (cm ²)				
7	Volume External (cm ³ /m) Internal (cm ³ /m)				
8	Moment of Inertia (cm ⁴)				
9	Modulus of Section (cm ³)				
10	Radius of Gyration (cm)				
11	Yield Stress (Mpa)				
12	Tensile Stress (Mpa)				
13	Elongation				
14	Permissible Axial stress in tension (Mpa)				
15	Actual Axial stress in tension(Mpa)				
16	Factor of Safety				
17	Permissible Axial stress in compression(Mpa)				
18	Actual Axial stress in compression(Mpa)				
19	Factor of Safety				
20	Permissible Bending stresses(Mpa)				
21	Actual Bending stresses(Mpa)				
22	Permissible Shear stress(Mpa)				
23	Actual Shear stress(Mpa)				
24	Ratio of combined bending and axial stresses				

- c) **Insulators:** The system shall allow use of porcelain or composite insulators; however, mounting system shall be same for both types. Insulators shall meet the requirement of RDSO specification No. TI/SPC/OHE/INS/0070 for porcelain insulator with minimum creepage distance **1050mm** or TI/SPC/OHE/INS/1071 (Rev.01) for composite insulator with minimum creepage distance **1600mm**. The metal parts of these insulators shall be as per the design of the manufacturer of MCS.

5.0 INSPECTION & TESTING:

- 5.1** MCS shall be inspected and tested by the Director General/TI [DG/TI]/RDSO, Lucknow or his authorized representative at the firm's work. All the proto type tests specified in clause 5.4 shall be carried out at the manufacturer's works. The firm shall arrange, without making any claim or charges, all the necessary machinery, apparatus, labour and assistance required to get the specified tests conducted in the presence of purchaser's representative. If certain facilities are not available for the tests, manufacturer may arrange these tests outside at Government approved Laboratories. The charges for these tests shall be borne by the manufacturer. After successful prototype Inspection & Testing, MCS shall be subjected to Field Trial as per clause 1.4.
- 5.2** Before giving call to RDSO for prototype testing of MCS, the manufacturer shall submit a detailed test schedule consisting of the details of each test and nature of the test, venue of the test and the duration of each test and the total number of days required to complete the test at one stretch. Once the test schedule is approved, the test shall invariably be done accordingly.
- 5.3** In case, any dispute or disagreement arises between the manufacturer and RDSO/Purchaser during the process of testing, as regards to the type test and /or

the interpretation and acceptability of the type test results, it shall be brought to the notice of DG/TI/RDSO, whose decision shall be final and binding.

5.4 TESTS:

5.4.1 The following type tests shall be conducted:

SN	TEST	TYPE TEST	ACCEPTENCE TEST	ROUTIN E TEST	Clause No. / Standard / Drawings
1.0	Visual examination (fittings & tubes)	Y	Y	Y	Cl.6.1
2.0	Verification of dimensions (fittings & tubes)	Y	Y	Y	As per approved Drawings
3.0	Chemical composition test (fittings & tubes)	Y	Y	Y	Cl.4.12
4.0	Radiographic Testing of fittings & Tubes	Y	Y	Y	Cl.6.2
5.0	Inter changeability test (fittings &tubes)	Y	Y	Y	Cl.6.3
6.0	Physical properties &failing load test For fitting	Y	Y	Y	Cl.6.4
7.0	Insulator's testing	Y	Y	Y	Cl.4.12
8.0	Test on Fasteners	Y	Y	Y	TI/SPC/OHE/FA STNERS/0120

5.5 Sampling for type test

- a) Three set of each fitting & tubes used in MCS shall be produced by the manufacturer, on which test as per clause 5.4 shall be carried out for ascertaining their conformity to the requirements of this specification.

The lot which has been found satisfactory in visual examination shall be tested for dimensional characteristics. Any items failing to meet one or more dimensional requirements shall be considered been found unsatisfactory, all the samples in the lot may be inspected for dimensional characteristics and the defective ones be removed, if agreed by the purchaser. The lot shall then be tested for the remaining tests. Any item failing to meet the requirement of tests, shall be considered as defective.

5.6ACCEPTANCE & ROUTINE TESTS: The manufacturer shall carry out the specified tests, during production, on the samples taken at regular intervals, to ensure conformity to relevant specifications as also to maintain proper control over the process of manufacture. The manufacturer shall maintain the frequency of the various tests and shall produce a certificate at the time of inspection, showing the frequencies of various inspections/tests which have been exercised during production.

6.0 TEST METHODS:

6.1Visual examination: -All fittings & tubes of modular cantilever systems shall be visually examined as per RDSO's Specification No. TI/SPC/OHE/Fittings/0130 (10/2013).Components made by casting process shall have clean finish and free from cracks, surface flaws, harmful inclusions, blow holes etc. No repair shall be done to the castings to hide defects. MCS shall also be checked for identification nos. and firms monogram, as mentioned in the relevant drawings.

6.2Radiographic Test: All cast components shall subjected to radiography as per ASTM E-155-00(2005)/DIN EN VDE 0216 and shall satisfy the RDSO Specification No.TI/SPC/OHE/Fittings/0130(10/13).

6.3 Interchangeability test: If the components (fittings/tubes) of one Modular cantilever are able to fit in place of components of other cantilever, randomly selected, without any further modifications for interchangeability and ease in erection & maintenance and MCS so made meet the requirements of clause 6.2, the requirement of this test shall be deemed to have been complied with.

6.4 Physical properties and failing load test: The tensile strength, yield stress and percentage elongation shall be determined in accordance with methods specified in ASTM B-557 and shall not be less than the values specified for the Grades given in

RDSO approved drawing. Bending test shall be conducted in accordance with ASTM B 317. Calculation for permissible stresses along with the copy of relevant standard shall be submitted.

7.0 CRITERIA FOR ACCEPTANCE OF FINISHED PRODUCT:

- a) Lot shall be made **from** the same production batch. Three modular assemblies from each batch shall be selected at random from the offered lot (not more than 100 nos.) for tests. Samples from three selected units shall be subjected to the tests as specified above.
- b) If any sample fails to comply with any test(s) specified in this specification, test(s) shall be repeated on three samples, taken from the same batch but limited to the test(s) in which failure occurred. If in the retest(s) any sample fails, the batch represented by the sample shall be deemed not to comply with specification and the complete batch shall be rejected.
- c) Only after clear written approval of the results of tests on the prototype is communicated by the DG/TI/RDSO to the manufacturer, he shall take up bulk manufacture of MCSs which shall be strictly with the same material and process as adopted for the prototype.

8.0 PACKING AND MARKING: Part identification No., Manufacturers monogram and month/year of manufacture shall be marked on each part of the MCS. The modular cantilever system complying with this specification shall be properly packed, duly assembled, in strong wooden boxes so as to avoid damage during transit. The box shall carry on its outer face the following information.

a)	Manufacturer's name	b)	Content details (Part Name, Part No. & Quantity)
c)	Net and gross weight	d)	Production batch number
e)	Contract number and consignee	f)	Any other particulars specified by the purchaser.
g)	Inspector's stamp and seal on components & box	h)	Date of inspection

9.0 INSTALLATION, COMMISSIONING & TRIAL: The manufacturer shall be responsible for installation, commissioning and to carry out trials of the MCS on the line to the satisfaction of DG/TI/RDSO. Necessary assistance in this regard shall be provided by the purchaser.

10.0 RELIABILITY:

- a) MCS assembly as a unit is expected to provide reliable service for at least 40 years irrespective of polluting & corrosive atmosphere such as in the coastal areas, in the vicinity of chemical plants and diesel loco sheds etc.
- b) The manufacture shall, therefore, ensure that the system supplied including all parts and components etc. used are free from manufacturing defect. MCS shall be of highest quality and in conformity with the specification.
- c) The manufacturer shall submit the schedule of guaranteed performance for MCS.

11.0 MAINTAINABILITY:

11.1 Manufacturer will submit to RDSO the requirements of maintenance.

- 11.2** The manufacturer shall provide the services of competent engineers at own expense during the warranty period for any manufacturing and design defects and also to impart instructions for regular service and maintenance.
- 11.3** The manufacturer shall furnish list of recommended spares, tool & plants for proper upkeep and trouble free service of MCSs.
- 11.4** An undertaking that spares shall be made available during the service life (40years) of MCSs shall be furnished along with the offer.

12.0 **WARRANTEE:** The manufacturer shall provide warrantee for satisfactory performance of MCS for a period of 30 months from date of supply & 24 months from the date of commissioning, whichever is earlier.

13.0 All the provisions contained in RDSO's ISO procedures laid down in document No.-QO-D-7. 1-1.1 dated 19.07.2016 (Titled " Vendor- change in approved status") and subsequent versions/amendments thereof, shall be binding and applicable on the successful vendor/vendors in the contracts floated by Railways to maintain quality of products supplied to Railways"

14.0 Modular cantilever should be compatible with Pantographs used in India Railways as given in Annexure-V.

15.0 The "Make in India" policy of Government of India shall be applicable.

.....

FINAL DRAFT

Annexure-I

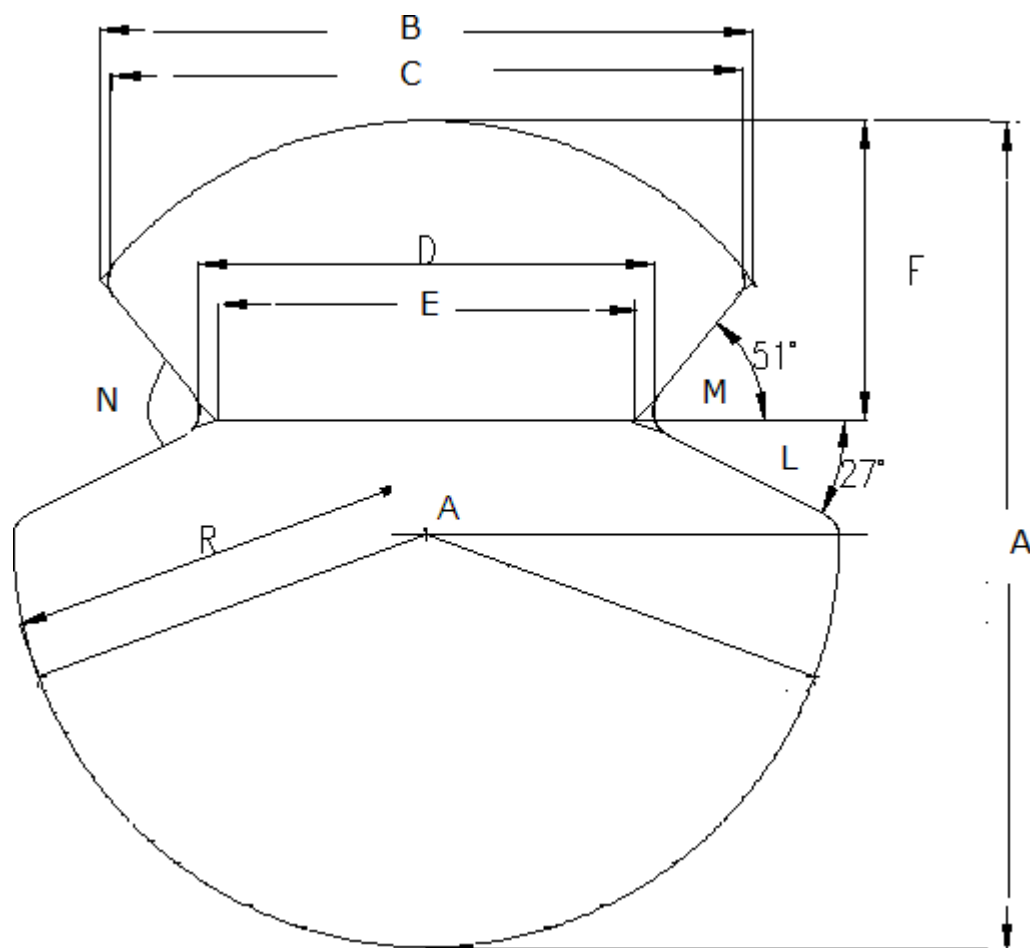
Contact wire profile

Cross Section of Contact Wire (mm ²)	Dimensions (mm)						Dimensions (Degree)		
	A	B	C	D	E	F	L	M	N
107	12.24±0.16	-	-	6.92±0.15	6.50	4.43	27(+1,-0)	51(+1,-0)	78(+2,-0)
150	14.50±0.20	-	-	6.92±0.15	6.50	4.00	27(+1,-0)	51(+1,-0)	78(+2,-0)
161	15.00±0.15	12.2	12.0 ±0.25	8.50(+0.18-0.30)	8.10	5.75	27(+2,-0)	51(+2,-0)	78(+3,-0)
193	16.40±0.15	12.2	12.0±0.25	8.50(+0.18-0.30)	8.10	5.3	27(+2,-0)	51(+2,-0)	78(+3,-0)

Annexure-II

EXISTING CANTILEVERASSEMBLY

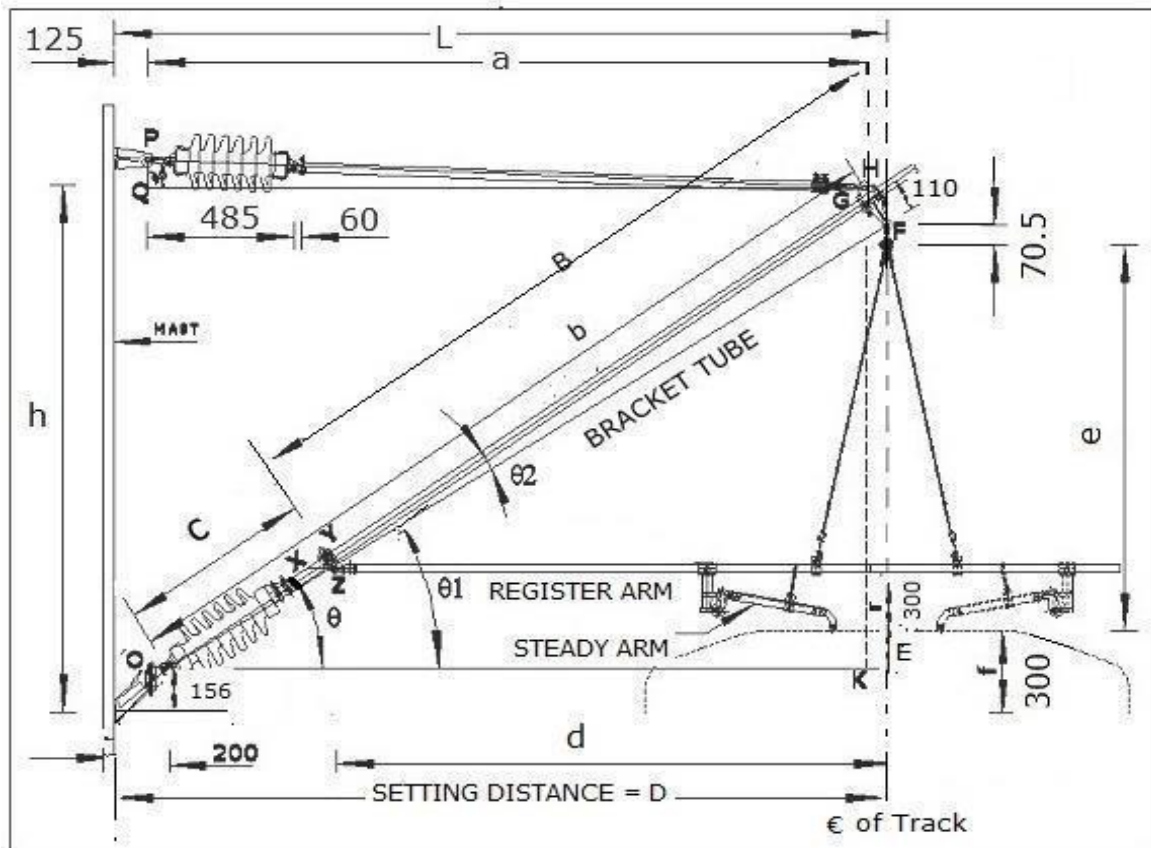

- a Distance between the Mast Stay Arm Fitting (Top Attachment) and the centre of Hook of Catenary Suspension Bracket.
- b Distance between the Vertical Axis of the Mast Bracket Swivel and the axis of the Catenary Suspension Bracket.
- c Distance from the bottom Cap of Bracket Insulator to the axis of the Register Arm Hook.
- c Horizontal distance between the centre of the Register Arm Hook and the vertical axis of Catenary Suspension.
- e Encumbrance
Distance between the axis of Catenary and Contact wires. It is normally kept 1400 mm.
- F Distance between Contact Plane and Mast Bracket Fitting. It is normally 300 mm.
- L Suspension Distance
Horizontal distance from the extreme face of Mast Stay-Arm Fitting to the Suspension point of Catenary wire. This is different from Setting Distance to the extent of stagger of Catenary Clamp and thickness of Multiple Cantilever Cross Arm or Extension Chairs, if provided.
- r Distance between the Contact Plane and the Register Arm axis (including Raised Register Arm) - which is assumed to be horizontal. It is normally 300 mm for the running Contact Plane.
- θ Inclination of Bracket tube to the horizontal
(as indicated) $\theta = \theta_1 + \theta_2$. It is generally 38° . Thus the Mast Bracket Fitting axis has an inclination of 38° to horizontal.

Annexure-III

Details of existing Cantilever assembly vis-a-vis Modular cantilever system components:

S N	Existing components			MCS components		
	Name of fitting	Part No.	Material	Name of fitting	Material	Standard
1	Tube, Standard(29.9/38)/ Large(40/49)		Hot Dip Galv. Steel	Support tube	Aluminum alloy	IS:1285 or its Equivalent Specification (EN/IEC/BS etc.)
2	Contact wire swivel clip	1220	Al. Bronze	Contact wire clamp complete	CuNi2 Si (Copp er Nickel Silicon)	EN 12165 or its Equivalent specification (EN/IEC/BS etc.)
3	Suspension clamp	1160	-do-	Suspension clamp	Aluminium alloy/Al. Bronze	TI/SPC/OHE/Fitt ing s/0130(10/13) or its equivalent specification. (EN/IEC/BS etc.)
4	Double suspension clamp	1170	-do-			
5	Standard catenary suspension bracket.	2110-1	-do-	Standard catenary suspension bracket		
6	Standard catenary suspension bracket bottom.	2111	-do-			
7	Standard catenary suspension bracket top	2112	-do-			
8	Large catenary suspension bracket.	2130	-do-			
9	Large catenary suspension bracket top.	2131	-do-	Large catenary suspension bracket		
10	Large catenary suspension bracket bottom.	2132	-do-			
11	Large catenary suspension bracket.	2130-1	MCI			
12	25mm steady arm clamp	2490-2	MCI	Steady arm clamp	Aluminium Alloy	
13	Steady rod piece	2341	Steel Galv.	Steady arm single bended		
14	Steady rod eye piece	2345	Al. Bronze			
15	Tubular stay adjuster.	2402	Steel Galv.			
16	Raised register arm adjuster 25 mm	2432	Steel Galv.			
17	BFB steady arm assembly	2390	Arm-Alu			
			Hook- MCI/Swiv el - Steel Galv .			

Note: If equivalent specification is proposed then the differences between the specified & proposed specification shall be submitted during submission of design details itself. It acceptance will be subjected to RDSO's approval.

Performance Report of Modular Cantilever System (MCS)

(To be filled up every month)

Railway: _____ Division: _____ Section: _____

S N	Name of fitting	Part No	Locati on	Date of Installation	Date of Inspection	Working performance			Remar ks
						Failure, if any	Details of abnormality observed, if any	Difficulty in operation, if any	

Performance ofMCS: Satisfactory/ Not satisfactory

Note: The Railway while giving the performance report shall also comment on the following:

- a) Parameters of checks at location specified by the manufacturer
- b) Reduction in time for assembly, dismantling & maintenance with existing Cantilever Assembly
- c) Reduction in weight of Components with existing Cantilever Assembly
- d) Reduction in the number of components with existing Cantilever Assembly.
- e) Any effect of industrial environment & resistance to corrosion.
- f) Whether or not usual periodicity of annual maintenance can be extended with the adoption of modular OHE.
- g) Wear of Contact wire/components
- h) Rusting of components/Tubes
- i) Problem in Opening /Tightening(Torque).

Annexure-V

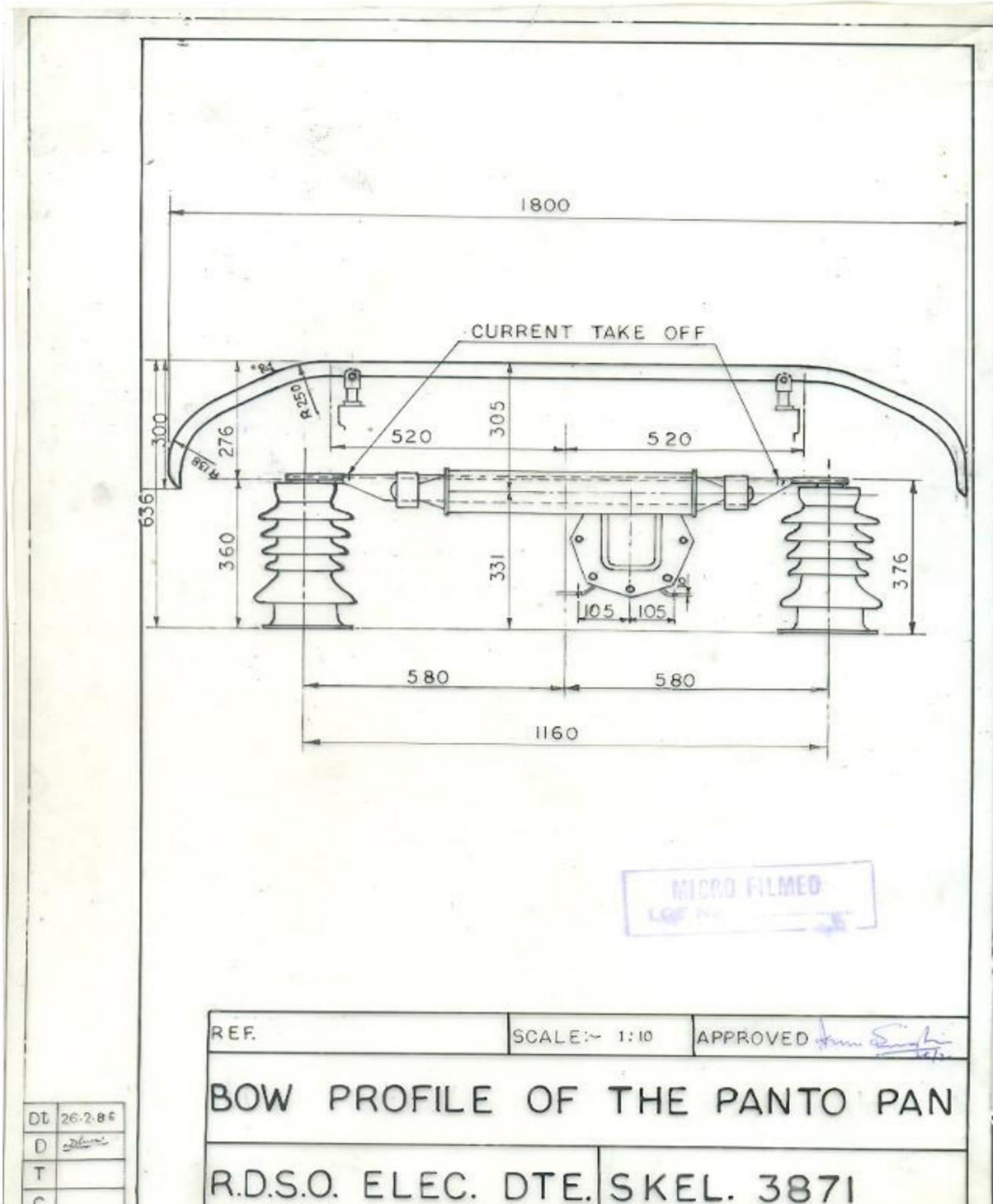

DL	26-2-88
D	<i>[Signature]</i>
T	
C	

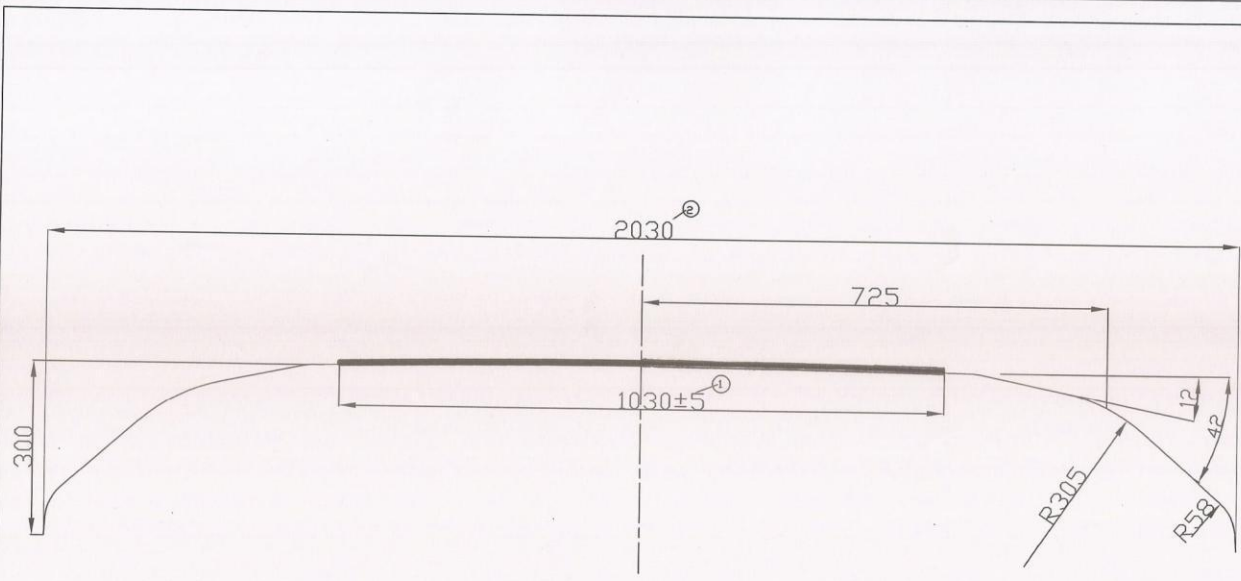

Note: 1. Length of contact strip 1030±5mm.
 2. Pantograph head length 2030mm (equivalent to conducting range)

REF: 1. RB's letter no. 2010/Elect/Dev/225/6 dt.10.02.14.
 2. DPCCL letter no. HQ/EL/RLY. BOARD/2 dt. 24.01.14.

SCALE: NTS APPD. BY *[Signature]* (FOR DG)

PANTO PAN PROFILE OF 2030 MM WIDE BOW		FIRST ISSUED
		SUPERSEDES
RDSO ELECT. DTE	SKEL 4992, Alt.'0'	SUPERSEDED BY

DT	07.03.14
D	VKYADAV
C	R Dasgupta

REVISION	DATE	DESCRIPTION

FINAL