



(For official use only)

भारत सरकार
रेल मंत्रालय

**GOVERNMENT OF INDIA
MINISTRY OF RAILWAYS**

**SPECIFICATION OF CAB MOUNTED COMPACT AIR CONDITIONING
UNIT WITH BUILT IN INVERTER TO BE USED IN DIESEL ELECTRIC
LOCOMOTIVES**

**SPECIFICATION NO. MP. 0. 4200.08 (REV.- 01)
JANUARY, 2013**

अनुसंधान अभिकल्प और मानक संगठन
लखनऊ-226 011.

**RESEARCH DESIGNS & STANDARDS ORGANISATION
MANAK NAGAR, LUCKNOW - 226011.**

SPECIFICATION OF CAB MOUNTED COMPACT AIR CONDITIONING UNIT WITH BUILT IN INVERTER TO BE USED IN DIESEL ELECTRIC LOCOMOTIVES

1.0 INTRODUCTION

- 1.1** It is proposed to install cab air conditioning system in diesel electric locomotives of Indian Railways. Cab air conditioning system includes one compact AC unit fitted in the driver's cab with input power supplied by an auxiliary source. This specification has been prepared to standardize the compact air conditioning unit with built-in inverter to be used in diesel loco cabs.
- 1.2** The specification covers design, development, testing, maintenance and performance of compact air conditioning unit with built-in inverter to be employed in diesel electric locomotives.
- 1.3** Motors used in the cab air conditioning system are alternating current machines whereas auxiliary supply available in diesel-electric locomotives is 74V DC from auxiliary generator. A built-in inverter is therefore required to convert 74V DC to power suitable for input to these motors.

2.0 GENERAL REQUIREMENT

- 2.1** The locomotive cab air conditioner assembly shall be used to provide interior cab temperatures in a comfortable range during high as well as low temperature weather conditions encountered during locomotive operation throughout the year.
- 2.2** Single, self-contained air conditioner module shall be used for cooling, filtering, and distributing re-circulated air within the cab with condensate drain connection, mounting and support structures.
- 2.3** The air conditioning system shall have sufficient capacity to meet following performance requirements:

Cooling capacity : (a) 5300 kcal/hr (1.75 TR approx.) at 35 °C ambient
 : (b) 4500 kcal/hr (1.5 TR approx.) at 50 °C ambient
 : (c) AC unit shall be able to operate continuously at 55 °C ambient without tripping of any control and without any damage.

Heating Capacity : 2.94kW at 74Vdc input

Humidity : 60% maximum inside the driver's cab.

Fresh air : 30 cubic mtr/hr

- 2.4** AC unit shall re-circulate the cab interior air volume through the evaporator core at a rate adequate to provide the cooling capacity as specified above. Similarly the condenser air flow shall be adequate to provide the condenser heat rejection necessary to obtain the cooling capacity specified above.
- 2.5** The temperature inside the cab shall be maintained between 24 deg.C to 29 deg.C in cooling mode. In heating mode it shall be between 19 deg.C to 21 deg.C. Temperature indication shall be provided on AC unit to indicate temperature in deg.C. Thermostats shall be preferably of electronic type.
- 2.6** The HVAC unit will be roof mounted and therefore must be weather proof.

3.0 GOVERNING SPECIFICATIONS

Assistance has been taken from following specifications:

Sl. No.	Publication no.	Title
1	IEC –60571	Rules for electronic equipment used on rail vehicles.
2	IEC-60571-1 (1990)	General requirements and tests for electronic equipment
3	IS: 659 (1964)	Safety code for air conditioning (Revised) Amendment-1.
4	IEC: 6077 (1968)	Rules for electric traction equipment.
5	IS: 8623 (1993)	Specification for factory built assemblies of switch-gear and control gear for voltage up to and including 1000 VDC
6	IS: 4237 (1982)	General requirements for switch gear and control gear for voltage not exceeding 1000V or 1200 VDC.
7	IS: 13947 (Pt.1) – 1993	Degree of protection provided on enclosure for low voltage switch gear and control gear.
8	IS: 4691 (1985)	Degree of protection provided by enclosures for rotating electrical machinery (First revision).

4.0 SCOPE OF SUPPLY

The scope of supply includes compact air conditioning unit with built-in inverter along with all the associated control, protection and indication equipment.

5.0 ENVIRONMENTAL CONDITIONS

The complete AC unit shall be required to work under following atmospheric conditions:

Ambient temperature	-25 to 55 deg C
Humidity	Up to 100% during rainy season
Altitude	Max. 1200 meter above mean sea level
Annual rainfall	Between 1750 mm to 6250 mm.
Dust	Extremely dusty and desert terrain in certain areas. The dust content in air may reach as high a value as 1.6 mg / m ³ .
Atmospheric conditions in coastal areas in humidity salt laden and corrosive atmosphere	(a) Maximum PH value : 8.5 (b) Sulphate : 7 mg / liter. (c) Max. concentration of chlorine : 6 mg / liter (d) Maximum conductivity : 130 micro semen / CM.

- 5.1** The AC unit shall be suitable for rugged service normally experienced for rolling stock where locomotives are expected to run up to a maximum speed of 160 kmph in varying climatic conditions existing throughout India.
- 5.2** All electrical sub-components contained in Air Conditioner System shall be capable of withstanding, in a non-operating mode, an ambient of 60 deg C for an indefinite period of time without affecting their ability to function properly. The motors used in this Air conditioner shall be so designed and rated that they will perform their function continuously under the maximum operating conditions of the Air conditioner without ill effects.
- 6.0 INVERTER :** The inverter shall be in-built within the AC unit. HVAC shall provide the following to interface with the inverter for protection and control:
1. High pressure and low pressure sensors
 2. Cabin return air sensor (CRAT)
 3. Outside Air Temperature (OAT)
 4. Over temperature switch (mechanical)
 5. Over temperature thermistor (optional)
 6. Selector Switch for HVAC mode (high/medium/low for cool, heat and vent)
 7. Mechanics for opening/closing fresh air door should be included but shall be separate from the inverter.

- 6.1** Materials shall be certified to meet the applicable performance criteria for flammability and smoke emission characteristics as per ASTM E 162 (Is <35) and ASTM E 662 (Ds (1.5) <= 100 and Ds (4.0) <= 200))

7.0 REQUIREMENTS OF THE AC UNIT

- 7.1** Complete AC unit shall be housed on the roof of the driver cab of the locomotive. Maximum space available on the driver cab is 1138 mm (Width across the loco) * 1286 mm (length along the loco) * 363 mm (height above loco roof) including mounting arrangements. The envelope size of space available for compact AC is shown at **annexure-C**. Tenderer is advised to visit the loco at any diesel shed/DLW to study the optimum equipment layout possible. Tenderer shall submit locations and layout dimensions of the complete cab AC unit that shall be finalized in consultation with RDSO. Special preference will be given for designs which occupy lesser space in view of space constraints.
- 7.2** Refrigeration system of the air conditioning system shall be a basic vapor compression cycle system and shall use R-134a as the refrigerant.
- 7.3** Air Conditioning unit shall be designed with a pressure shut-off feature in the refrigerant circuit so that in conditions of extreme over pressure, it will cause the air conditioning to shut off and eliminate any possibility of discharging refrigerant into the cab during said conditions of over pressure.
- 7.4** All wiring should have sufficient insulation quality and secured properly so as to withstand handling during maintenance.
- Air Conditioning System shall be so designed that it will be completely self contained requiring only electrical power supply connections and control connections dependent on locomotive circuits and two drain connections, and that the rapid removal from the locomotive is possible. The system shall be provided with suitable lifting arrangement for easy maintenance.
- 7.5** The built-in inverter shall use MOSFET power semi-conductor devices.
- 7.6** Nominal input voltage is 74 VDC. However, AC unit shall operate satisfactorily in case input voltage varies between 50 VDC to 90 VDC.
- 7.7** The built-in inverter with all electronic and power devices shall be designed to survive the typical noise and spikes on the locomotive power under minimum/maximum current / voltage limits and current/voltage surges that may be expected during fault conditions.
- 7.8** The inverter should have sufficient overload capacity to supply high starting current required for different motors of air conditioning unit. The compressor motors some time may start with some amount of gas back pressure resulting in requirement of

higher starting torque. This shall also be taken into account while deciding the maximum current limit.

- 7.9** All motors used in this Air Conditioning System shall be totally enclosed and environmentally sealed unless tenderer can supply evidence acceptable to RDSO that deviation will not be detrimental to either performance, reliability or operation. All the motors shall be suitable for working at continuous ambient temperature of 60 °C.
- 7.10** The AC Unit shall be provided with suitable lifting arrangement for easy maintenance. The maintenance / inspection of the complete unit and replacement of any sub-component should be easy. The equipment / components needing periodic service attention shall be easily accessible from inside of the cab.
- 7.11** AC unit may have either painted cabinet or cabinet made from corrosion resistant grade 304 of stainless steel including housing sheet and structural materials. In case of painted cabinet, all surfaces of the cab AC unit shall be painted with a good grade of exterior paint to prevent corrosion. The external surface of the AC system shall be paintable without necessitating the application of primer
- 7.12** The Air Conditioner shall not have a noise output in excess of 78 dbA when operating under any specified condition of load or supply voltage. Noise measurement shall be 24 inches to each side of the Air conditioner and 30 inches below the center point of each evaporator air discharge grill. Main noise generating equipment shall have anti-vibration resilient mountings.
- 7.13** The insulating material used shall be of fire retardant type preferably resin bonded fiberglass or fire retardant polyethylene or any other suitable material.
- 7.14** All driven equipment, such as refrigeration compressors and blowers, shall be directly coupled to the driving motor using appropriate flexible couplings where necessary. Belt drives shall not be acceptable.

8.0 MODES OF OPERATION

8.1 COOLING MODE

In this mode, the heating elements will remain 'OFF' and evaporator fan motor, condenser motor and compressor motor will be in operation. The evaporator fan motor will be continuously 'ON' in this mode whereas the condenser motor and compressor motor will work intermittently depending on temperature requirement in the cab. This control shall be handled by inverter/controller supplied by the firm.

8.2 HEATING MODE

In this mode, the compressor motor and condenser motor are switched 'OFF' whereas heating elements and evaporator fan motor will be switched 'ON' to circulate

hot air inside the cab during winter season. The heating elements will be working intermittently depending on temperature requirement in the cab whereas the evaporator fan motor will operate continuously. This control shall be handled by inverter/controller supplied by the firm.

9.0 STARTING SCHEME

The built-in inverter shall take care of starting scheme of the AC unit. The starting scheme of the inverter shall be designed to avoid heavy in - rush current from input source during starting of the AC unit.

10.0 SAFETY CONSIDERATIONS

10.1 Appropriate warning labels and safety provisions shall be made in the AC unit and Inverter system to caution the personnel against potential hazards and to prevent direct human contact to any electrical live part or rotating shaft during AC operation.

Air Conditioning System shall be so designed and constructed that no sharp corners or edges are present in the locomotive cab. Such edges and corners shall be liberally rounded.

11.0 RELIABILITY

11.1 Air Conditioning System shall perform its design functions without exceeding the hereinafter stipulated failure rates for a period of 24 months after delivery of a locomotive so equipped or 250,000 miles service by said-locomotive.

<u>COMPONENT</u>	<u>FAILURE RATE</u>
Air conditioner Assembly (Total)	2.0%
Inverter	0.5%
Motors	0.5%
Electrical Control Devices	0.5%
Heat Transfer Coils	0.5%
Wiring and Connectors	0.01%
Mechanical Compressor Coupling	0.5%

11.2 A failure shall be construed as any occurrence not attributable to outside influence beyond this specification, which causes the Air Conditioning System to fail to perform its specified function.

11.3 These reliability criteria shall be used as a guide in the choice of material or components, general design, quality control effort, engineering life, endurance testing and refinement of system for complex operating environment.

12.0 WARRANTY

The complete AC unit including built-in inverter, motors and controls shall be warranted for satisfactory and trouble free operation for a period of 24 months from the date of supply. All aspects of workmanship and design shall be covered by this warranty excluding all wearing parts which require recurring replacements. A list of such wearing parts shall be furnished in the offer.

13.0 INFORMATION TO BE FURNISHED BY THE SUPPLIER

The tenderer shall submit the technical information with the offer as detailed below :

- a) Technical specifications, test results, ratings, performance data of the HVAC unit.
- b) Circuit diagrams
- c) Drawings and details of mounting arrangement of various equipment used.
- d) Details of protections provided
- e) Details of cooling arrangement used (if any).
- f) Details of operating panel and function of each switch, indications and fault diagnostic features.
- g) Data sheet of AC unit duly filled as per **annexure – B**.

14.0 APPROVAL OF DESIGN/DRAWINGS

14.1 After placement of order, the approval of detailed design and drawings will be advised by RDSO for which drawings shall be submitted by the tenderer. The tenderer shall furnish relevant performance data and ratings, calculations, technical specifications, test results, and relevant equipment drawings and descriptive write-up etc. necessary for correct appreciation of the offer. Approval of the drawings would mean approval of general adaptability of design features to the specified conditions of service. RDSO will not be responsible for the correctness of the dimensions in the drawings, the material used, the adequacy of the designs for the satisfactory performance of the equipment etc for which the supplier shall be wholly and completely responsible. The comments received from purchaser railways shall also be studied and discussed with RDSO.

14.2 Based on provisional approval of design/drawings, prototype unit shall be manufactured after incorporating all the modifications found necessary during inspection / testing without any additional charges.

15.0 ELIGIBILITY CRITERIA

As a pre-qualification criteria, the successful tenderer should have supplied same or similar designs of modular AC unit (with built in inverter) for at least 200 locomotives. The units should have worked on locomotives satisfactorily for at least 3 years. The tenderer shall submit the details of AC units supplied for locomotive applications.

16.0 INSPECTION AND TESTING

The prototype cab AC unit (with built-in inverter and controls) shall be type tested by RDSO at manufacturer's works or at a reputed test facility (to be accepted by RDSO). The routine tests are to be carried out by the manufacturer and record kept in proper format. Nominated representative of railways may ask and see the routine test results conducted.

16.1 Test program of AC unit is attached at **annexure - A**. The tenderer shall submit a type and routine test plan for acceptance by RDSO.

16.2 In general, the various equipment used in the AC unit shall conform to relevant IEC/IEEE (latest revisions) specifications and the same shall be indicated by the tenderer for each equipment. However, the maximum temperature rise limits specified in these standards shall be reduced by 20 deg C for the equipment used in AC unit to account for the higher ambient temperatures observed in India. In case any deviation is proposed from the said standards or from this specification, the standards followed shall be clearly indicated by the tenderer.

17.0 FIELD TRIALS

One prototype cab AC unit shall be subjected to field trials on IR for at least three months. The manufacturer shall depute a team of engineers for commissioning, testing and field trials of the cab AC unit in service. The manufacturer shall associate in the field trials jointly with IR. The manufacturer shall ensure availability of typical tools & spare parts in adequate quantity for field trials, to be done as part of commissioning.

17.1 All the modifications required due to defects noticed or design improvements found necessary as a result of the field test / trials shall be carried out by the tenderer in the least possible time. Total cost of such modifications/design changes shall be borne by the manufacturer.

18.0 FAILURES DURING WARRANTY PERIOD UNDER MAINTENANCE CONTRACT

18.1 The details of failures, action taken to arrest re-occurrence of similar failure in future, failure analysis report etc. are to be submitted to RDSO and purchaser railways.

18.2 In case of repeated failures, necessary changes in design on the units put in service

or in production line shall be made by the manufacturer. Investigation tests, if considered necessary, shall be arranged/conducted by the manufacturer.

19.0 MARKING AND PACKING

- 19.1** Air Conditioning Unit shall bear for identification a serial number and manufacturer's name as well as the type of unit, ratings and month/year of manufacturing.
- 19.2** All units of the complete AC system shall be suitably packed in strong boxes to prevent any damage during transit and handling.

ANNEXURE - A**TESTS FOR AC UNIT**

1.0 Following table lists the summary of type and routine tests to be conducted on the AC unit :

SN	Test Name	Type	Routine	Remarks
1	Dimensional & visual inspection	yes	yes	
2	Test for water tightness (a) Rain test (b) Test for drainage of condensate water	yes	no	
3	Electrical test (a) Insulation resistance test (b) high voltage test (c) Voltage change test (d) High temperature startup test	yes	yes	No high-temp startup test or voltage change test during routine tests
4	Fresh air quantity test	yes	no	
5	Conditioned air delivery test	yes		
6	Cooling capacity test	yes	no	
7	Measurement of power	yes	yes	
8	Heating capacity test	yes		
9	Vibration test	yes		
10	Shunting shocks test	yes		
11	Noise test	yes		

Routine tests shall be conducted on each AC unit at the manufacturers work. The manufacturer shall submit a copy of routine test results for each AC unit to the inspecting authority.

1.1 DIMENSIONAL & VISUAL INSPECTION

It shall be done for checking the overall dimensions, location of lifting hooks, material of filters, accessibility of different types of motors, filters, thermostats & protective devices, quality of welding etc.

1.2 TEST FOR WATER TIGHTNESS

The AC unit shall be tested for water tightness as per details given below :

1.2.1 RAIN TEST

The water tightness of the body and electrical equipment shall be inspected at all openings which might allow penetration of water. A distinction shall be made between the water tightness of openings (air inlet etc.) which depends primarily on erection and the condition of joints.

- (1) A check on the water tightness of the openings shall be carried out for a period of 30 minutes with all fans running under artificial rain of an intensity not less than 60 mm per minute. The angle of rain shall be 45 degree towards evaporator compartment from condenser side.
- (2) A check on the water tightness of covers shall be conducted. It shall be carried out by means of a jet of 6 to 10 mm internal diameter, at a distance of 2 meters and a pressure of 1 bar with all fans running and then at a pressure of 3 bars with the fans stopped. The water shall be sprayed on each cover side minimum for 15 minutes.
- (3) In each case the penetration of water shall be slight and shall not be of such nature as to have an adverse effect on cabling and electrical equipment.

1.2.2 TEST FOR DRAINAGE OF CONDENSATE WATER

This test will be conducted to see the efficacy of condensate water drain out system from the AC package unit with blower motor in working condition.

1.3 ELECTRICAL TESTS

1.3.1 INSULATION RESISTANCE

Insulation resistance of motors (compressor motor, condenser motor etc.) shall be more than 50 mega-ohms with 1000V DC megger in all the weather conditions.

1.3.2 HIGH VOLTAGE TEST

The Air Conditioner system with all sub-components shall be capable of withstanding a high voltage test for one minute duration using an applied voltage of 1000 volts AC RMS at 50 hertz frequency applied to appropriate terminals of the Air Conditioner or it's sub-components.

1.3.3 VOLTAGE CHANGE TEST

During the normal operation of the AC unit under cooling capacity test condition and high temperature condition, the power source voltage will be changed from 50 to 90 Vdc. The AC unit shall operate as required, but lower capacity is allowed below 74VDC.

1.3.4 HIGH TEMPERATURE STARTUP TEST

The condenser room temperature shall be maintained at 55 deg. C. The AC unit shall be made to run for one hour as per clause 1.6 (dry summer conditions). The unit should work satisfactorily without tripping of any of the protective devices.

1.4 FRESH AIR QUANTITY TEST

Measurement of fresh air quantity shall be made when fresh air openings are fully open and fresh air should be measured at lowest evaporator blower speed setting.

1.5 CONDITIONED AIR DELIVERY TEST

Manufacturer shall submit test certificate from a reputed test laboratory for the suitability of filters.

1.6 COOLING CAPACITY TEST

(a) This test shall be made in the following conditions:

Test condition	Condition created in hot chamber	Condition created in cold chamber
Dry summer condition	50 deg.C (DB) 25 deg.C (WB)	25 deg.C (DB) 16 deg.C (WB)

(b) Cooling capacity from evaporator side shall be calculated as under:

$$C = (60 \times Q \times (E1-E2)) / S$$

Where C = Cooling capacity (K. cal/h) evaporator side.

Q = Conditioned air quantity (m³ /min.) of evaporator blower fan.

E1 = Enthalpy of supply air (K. cal/kg)

E2 = Enthalpy of returned air (K. cal/kg)

S = Specific volume of supply air (m³/kg.)

(c) Cooling capacity from condenser side shall also be determined as under :

$$C_c = (60 \times Q_c \times (E3-E4)) / S_c - (E_t \times 0.86)$$

Where

C_c = Condenser side total cooling capacity (K. cal / hr.)

Q_c = Air flow rate over condenser per minute.

E₃ = Enthalpy of air entering condenser (K. cal / kg.)

E₄ = Enthalpy of air leaving the condenser (K. cal / kg.)

S_c = Specific volume of air flowing over the condenser (m³ / kg.)

E_t = Total power input to module in watts.

1.7 MEASUREMENT OF POWER

Total power input to whole AC unit as well as to each of the motors shall be recorded. Above measurements shall also be recorded while doing air delivery test under routine test.

1.8 HEATING CAPACITY TEST

Measure KW rating of heater provided.

1.9 VIBRATION TEST

Air Conditioning System with all sub-components shall be capable of withstanding vibration levels as per IEC 77 while operating at its rated points without any effects detrimental to the performance, operation, or reliability.

1.10 SHUNTING SHOCKS TEST

Air Conditioning System with all sub-components shall be capable of withstanding shock loads as per IEC 77 while operating at its rated points without any effects detrimental to the performance, operation, or reliability.

1.11 NOISE TEST

Maximum permissible noise level of the air conditioner is 78 db under any operating conditions, when measured 24 inches to each side of the air conditioner and 30 inches below the center point of each evaporator air discharge grill.

1.12 DEGREE OF PROTECTION FOR MOTORS

Degree of protection for motors shall be adequate for the application.

ANNEXURE - B

DATA SHEET FOR AC UNIT

(TO BE FURNISHED BY THE SUPPLIER)

A/C package unit model/type
Make of the AC unit
Cooling capacity of the unit
Over all dimensions (length x width x height)
Weight of the complete AC unit
Refrigerant used
Conditioning air output and static head in water gauge
Fresh air quantity
Total power input for the AC unit under conditions of cooling and heating

Rated voltage, power supply input
Full load current at rated voltage and at minimum voltage

FILTERS

Type of filters (Dry/Wet)
Overall dimensions
Filtration area
Filtration medium
Filtration efficiency
Air flow rate capacity
Method and frequency of cleaning

MOUNTING AND OTHER DETAILS

Mounting details of the package unit offered, design and structural frame details.
Draining arrangement for the condensate water.
Details of opening arrangement for maintenance/attention.
Details of lifting arrangement for mounting and dismantling the AC unit from the short hood compartment.

ANNEXURE-C

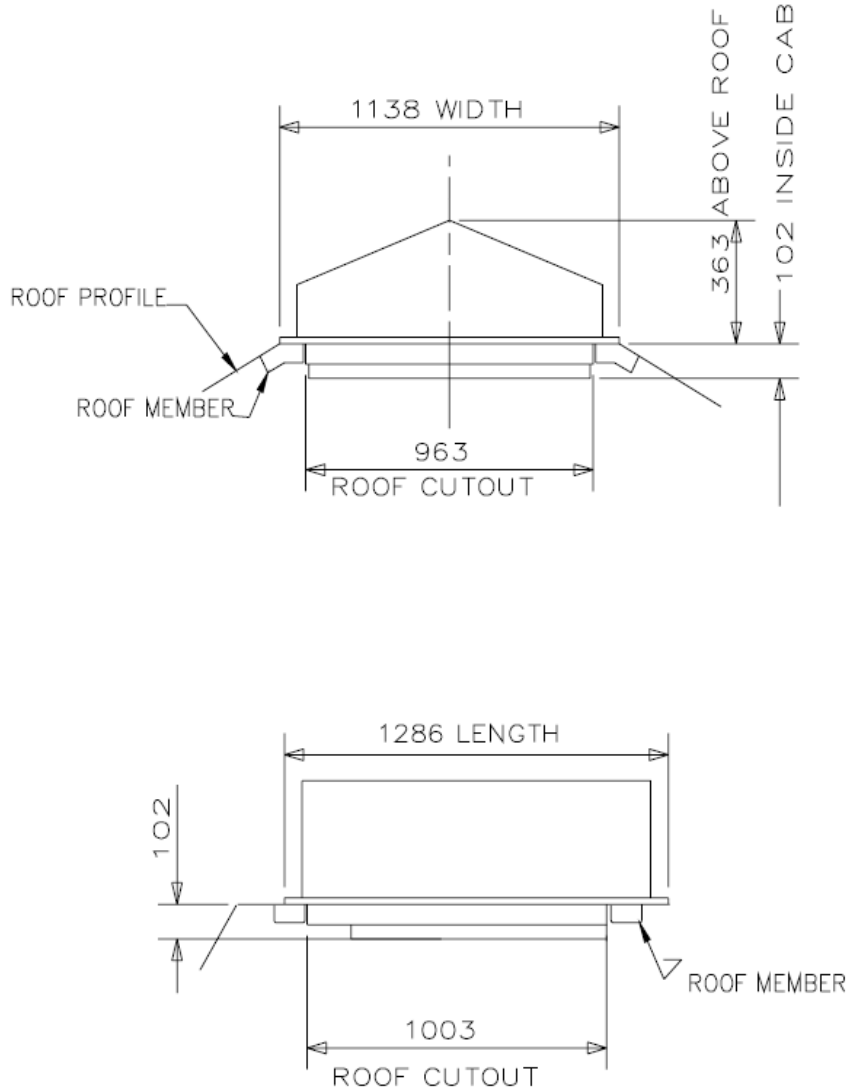

SKETCH SHOWING THE ENVELOP DIMENSIONS OF
COMPACT CAB AC EQUIPMENT ON GM LOCOMOTIVES