



**SPECIFICATION  
FOR  
DATA LOGGER SYSTEM  
FOR  
RAILWAY S&T INSTALLATIONS**

**IRS: S: 99/ 2006**

**APRIL 2006**

**Pages : 63**

**Research Designs & Standards Organisation  
Lucknow – 226 011**

| DOCUMENT DATA SHEET  |  |  |                              |
|--|--|--|------------------------------|
| <b>Designation</b><br><b>IRS:S:99/ 2006</b>  |  |  | <b>Amendment</b><br><b>3</b> |
| <b>Title of Document</b><br>Data Logger System for Railway S & T Installations.                                      |  |  |                              |
| <b>Authors:</b><br><br><b>Shrikant Singh</b><br><b>Designation: Executive Director / Signal/ RDSO</b>                |  |  |                              |
| <b>Approved by</b><br><br><b>Name: Shri G. D. Bhatia</b><br><b>Designation: Sr. Executive Director/ Signal, RDSO</b> |  |  |                              |
| <b>Abstract</b><br>This document defines Data Logger System for Railway S & T installation.                          |  |  |                              |

DOCUMENT CONTROL SHEET

| NAME                  | ORGANIZATION | FUNCTION      | LEVEL          |
|-----------------------|--------------|---------------|----------------|
| <b>Shrikant Singh</b> | <b>RDSO</b>  | <b>Member</b> | <b>Prepare</b> |
| <b>G.D. Bhatia</b>    | <b>RDSO</b>  |               | <b>Approve</b> |

## AMENDMENTS

| <b>Version</b>   | <b>Chapter/<br/>Annexure</b> | <b>Amendment</b> | <b>Effective date</b>           |
|------------------|------------------------------|------------------|---------------------------------|
| IRS: S: 99/ 2001 |                              | FIRST ISSUE      | August 2001                     |
| IRS: S: 99/ 2001 |                              | Amendment 1      | 12 <sup>th</sup> February 2002  |
| IRS: S: 99/ 2001 |                              | Amendment 2      | 30 <sup>th</sup> September 2004 |
| IRS: S: 99/ 2006 |                              | Amendment 3      | 5 <sup>th</sup> April 2006      |

**Amendment 3 ( Details )**

| Sl. | Clause                | Amendment | status                                 | Remarks  |
|-----|-----------------------|-----------|--|--|
| 1.  | 1.2                   | 2         | Add                                    | To clarify The scope of inspection of Modem & CMU          |
| 2.  | 3.3                   | 3         | Modified                               | Output relay capable to drive 24V Q-Series Relay           |
| 3.  | 3.4                   | 3         | Modified                               | Field gear shall not load >1%                              |
| 4.  | 3.7                   | 3         | Modified                               | Forced Cooling to be deleted                               |
| 5.  | 3.8                   | 3         | Modified                               | To Print in user friendly mode                             |
| 6.  | 3.9                   | 3         | Modified                               | Format to include location name& Channel no.               |
| 7.  | 3.10.1 (vii) & (xvii) | 3         | Deleted & subsequent clause renumbered | To delete Three position inputs                            |
| 8.  | 3.10.2 (iv)           | 3         | Deleted & subsequent clause renumbered | Covered by Digital Input                                   |
| 9.  | 3.13                  | 3         | Add                                    | To include Version control                                 |
| 10. | 4.1(vi)               | 2 & 3     | Add                                    | To add modem   |
| 11. | 4.2.2                 | 3         | Modified                               | RTU Event Capacity Defined                                 |
| 12. | 4.2.7.1               | 1&3       | Deleted                                | To delete synchronization of control office digital clock  |
| 13. | 4.2.10                | 3         | Modified                               | Storing capacity to increase upto 10 lac                   |
| 14. | 4.2.12                | 1&3       | Add & Modified                         | To clarify input variation storing percentage of analog    |
| 15. | 4.2.17                | 3         | Modified                               | Power Supply as per spn 144                                |
| 16. | 4.2.18                | 3         | Modified                               | To make modular & Ergonomic design                         |
| 17. | 4.2.19                | 2 & 3     | Add                                    | To include transmission media                              |
| 18. | 4.2.20                | 2         | Add                                    | Common protocol between RTU & DL                           |
| 19. | 4.2.21                | 3         | Add                                    | Capacity of one cabinet 1024 Digital & 64 Analog           |
| 20. | 4.2.22                | 3         | Add                                    | Termination of All input Like Wago etc                     |
| 21. | 4.3.1                 | 2 & 3     | Modified                               | Specification of PC for CMU upgraded to state of art & Sub |

|     |               |       |          |   |
|-----|---------------|-------|----------|---|
|     |               |       |          | clause added  |
| 22. | 4.3.8         | 3     | Modified | FEP must have capacity to store 10 lac telegrams                      |
| 23. | 4.3.9         | 1 & 3 | Modified | Details of common protocol  |
| 24. | 5.5           | 3     | Modified | Transmission rate to increase up to 57600 BPS                         |
| 25. | 5.6.1         | 3     | Modified | Sub clause Number given   |
| 26. | 5.6.2         | 3     | Modified | Sub clause Number given   |
| 27. | 6.3.1         | 3     | Add      | Applied high voltage test added                                       |
| 28. | 7.1           | 3     | Add      | Sub clause number given   |
| 29. | 7.2           | 3     | Modified | IR test as per RDSO/SPN/144/2006 & Sub clause added                   |
| 30. | 7.3           | 3     | Modified | Environmental as per RDSO/SPN/144/2006 & Sub clause added             |
| 31. | 7.4           | 3     | Add      | Applied high voltage test as per RDSO/SPN/144/2006 & Sub clause added |
| 32. | 10.4          | 3     | Add      | Pre-commissioning check list & DOs and DON'Ts                         |
| 33. | 11.1.1        | 3     | Modified | Sub clause given number   |
| 34. | 11.2          | 3     | Modified | “Additional” ward added   |
| 35. | 11.4 (c)      | 2     | Delete   | Deleted against Cl:4.1.(a) (vi)                                       |
| 36. | 11.5 & 11.5.1 | 3     | Delete   | Deleted against Cl:4.2.17   |
| 37. | Annexure      | 3     | Add      | Added as per clause 4.3.9   |

**TABLE OF CONTENTS**

| <b>S. No.</b> | <b>Item</b>                                    | <b>Page No.</b> |
|---------------|--|-----------------|
| 1             | Foreword                                       | 8               |
| 2             | Scope  | 8               |
| 3             | Terminology                                    | 9               |
| 4             | General requirements                           | 9               |
| 5             | Technical requirements                         | 11              |
| 6             | Data logger equipment                          | 12              |
| 7             | Central monitoring unit                        | 15              |
| 8             | Functional requirements                        | 16              |
| 9             | Exception report                               | 16              |
| 10            | Test and requirements                          | 18              |
| 11            | Test equipment                                 | 18              |
| 12            | Type tests                                     | 18              |
| 13            | Acceptance test                                | 19              |
| 14            | Routine test                                   | 19              |
| 15            | Test procedure                                 | 19              |
| 16            | Visual inspection                              | 20              |
| 17            | Insulation resistance test                     | 20              |
| 18            | Environmental/climatic tests                   | 20              |
| 19            | Applied high voltage test                      | 20              |
| 20            | Quality assurance                              | 20              |
| 21            | Plant & machinery                              | 21              |
| 22            | Packing  | 21              |
| 23            | Information to be supplied by the manufacturer | 21              |
| 24            | Information to be supplied by the purchaser    | 22              |
| 25            | Annexure                                       | 24-63           |
| A.1           | Scope  | 24              |
| A.2           | Network  | 24              |
| A.3           | Message formats                                | 25              |
| A.4           | Event packet                                   | 34              |
| A.5           | Acknowledgement Packet                         | 49              |
| A.6           | Command Format                                 | 50              |

**GOVERNMENT OF INDIA  
MINISTRY OF RAILWAYS  
(RAILWAY BOARD)**

**INDIAN RAILWAYS  
STANDARD SPECIFICATIONS**

**FOR**

**DATA LOGGER SYSTEM**

**(TENTATIVE)**

**Serial No. S 99/ 2006**

**0 FOREWORD**

0.1 This specification is issued under the fixed serial number followed by the year of adoption as standard or in case of revision, year of latest revision.

0.2 This specification requires reference to the following specifications: -

IRS: S23                      Electrical signalling and interlocking equipment

RDSO/SPN/144              Safety and reliability requirement of electronic signalling equipment

IS: 9000                      Basic environmental testing procedures for electronic and electrical items

Wherever, reference to any specification appears in this document, it shall be taken as a reference to the latest version of that specification unless the year of issue of the specification is specifically stated.

**1 SCOPE**

1.1 This specification covers the technical and operational requirements of data logger equipment, which is installed to monitor the status of the signalling gears



at stations. It also covers minimum configuration of central monitoring unit (CMU).

- 1.2 Inspection shall be carried out for data logger equipment consisting of RTU, FEP and CMU software. Standard accessories used external to the data logger like PC for CMU, UPS for CMU and modem etc. shall be checked during inspection for their functional performance only required for data logger system as per specification.

## **2 TERMINOLOGY**

- 2.1 For the purpose of this specification, the terminology given in IRS: S23 and RDSO/ SPN/144 shall apply.
- 2.2 Input module means an electronic module/ card used to read status of relays (digital input) and/or level of analog signals.
- 2.3 Signal Conditioner means an electronic module or card used to convert analog signals to a suitable level for recording.
- 2.4 SSI/ Electronic interlocking is a processor based electronic system to control signalling equipments/ functions at any interlocked station.
- 2.5 Integrated power supply (IPS) is a composite module delivering various AC and DC voltage for signalling equipment.

## **3 GENERAL REQUIREMENTS**

- 3.1 The system shall chronologically monitor and record the status of various field functions like track circuits, points, signals, operator's push buttons/switches (digital Inputs) and level of various analog signals like DC and AC supply voltages, Axle counter signals etc.
- 3.2 The equipment shall also have the capability of statistical analysis, predict the faults and generate failure reports. It shall be possible for the user to define fault logics taking digital/analog inputs into consideration and generate reports for such faults.
- 3.3 The equipment shall be capable of generating audio-visual alarm under defined conditions. In addition, it shall be able to deliver non-vital relay outputs on receipt of command from CMU. At least 8 non-vital relay outputs shall be provided. The non vital relay output shall be in the form of potential free contacts capable of

driving 24V 'Q' series relays These outputs may be used for non-vital functions like radio patching of control circuits etc.

- 3.4 For digital inputs, potential free contacts shall be used. Analog signals shall be scaled to a suitable limit using signal conditioner before converting to digital signal. While tapping analog input, it shall not load the analog channel/ field gear by more than 1% of rated load.
- 3.5 The system shall be suitable for working on non electrified, AC electrified and DC electrified areas and where passenger/freight trains hauled by single phase thyristor controlled or three phase induction motor controlled AC locomotives or chopper controlled EMU stock are operated.
- 3.6 The system shall be capable of working in conjunction with conventional relay interlocking, multi-aspect colour light signalling installations operated by lever frames/ slides & Electronic Interlocking systems. It shall have facility to log data received from Electronic Interlocking through a serial port.
- 3.7 The system (except commercial PC used for CMU) shall be capable of working in an ambient temperature range of  $-10^{\circ}$  C to  $+70^{\circ}$  C and relative humidity up to 95% at ambient temperature of  $40^{\circ}$  C. Special protection against ingress of dust, moisture etc. shall be provided.
- 3.8 The data logger shall be capable of being connected to a printer for obtaining a hard copy of the function recorded. It shall be possible to print the following on the connected printer by selecting from user friendly menu
- (i) on line events as they are generated.
  - (ii) to print the exception report
  - (iii) to print the status of user specified inputs for user definable time period
- 3.9 The data logger shall record various field functions as indicated in para 3.10 below chronologically in the following format with name of the location at top of every page:

Date,      time,      channel no.,      field function,      status / value

- 3.10 The status of various functions shall be recorded in the following way: -

3.10.1 Digital Input:

|    | <b>Functions</b> | <b>Status configuration</b>           |
|----|------------------|---------------------------------------|
| i) | Points           | Normal or reverse (N or R), locked or |

|       |                          |   |
|-------|--------------------------|---|
|       |                          | unlocked                                  |
| ii)   | Signal                   | ON or OFF (Y, YY, R, G, RI, A marker)     |
| iii)  | Track                    | Occupied/Free                             |
| iv)   | Level crossing           | Locked/Free                               |
| v)    | Crank handle             | Locked/Free                               |
| vi)   | Axle counter             | Occupied /free                            |
| vii)  | Route                    | Locked /free                              |
| viii) | Route sections           | Locked / free                             |
| ix)   | Push buttons             | Pressed/released                          |
| x)    | SM's key                 | In/Out                                    |
| xi)   | Slots                    | Given/ not given; Received / not received |
| xii)  | Insulation of Sig. Cable | Good /bad (through ELDs)                  |
| xiii) | Slots (Outgoing)         | Locked/ released                          |
| xiv)  | Slots (Incoming)         | Received /Absent                          |
| xv)   | Switch (2 position)      | Normal/ Reverse                           |
| xvi)  | General Relay            | Pickup / drop                             |

### 3.10.2 Analog inputs

|      | <b>Functions</b>                        | <b>Status configuration</b> |
|------|---|-----------------------------|
| i)   | Axle counter Rx signal at the tag block | Value                       |
| ii)  | AC power supply (230/ 110V)             | Value                       |
| iii) | DC supply (12/24/48/60/110 etc.)        | Value                       |
| iv)  | Temperature                             | Value                       |

The purchaser shall indicate any additional field information required to be recorded.

- 3.11 The system shall be easily re-configurable to any changes required by user, whenever modifications are carried out in the yard.
- 3.12 Provision for networking and remote monitoring of several data loggers from the central place shall be provided.
- 3.13 Implementation of version control and change of software shall be as per RDSO/SPN/144

## **4 TECHNICAL REQUIREMENTS**

4.1 Data logger system consists of:

- (a) Data logger equipment which is provided near the signalling gears to be monitored has following modules:
  - (i) Processor module.
  - (ii) Input module (digital/ analog)
  - (iii) Signal conditioning module
  - (iv) Communication module
  - (v) Printer 80 Col. Dot matrix (Optional)
  - (vi) Modem(s)
- (b) Central monitoring unit (if provided) with communication facility to retrieve data from data logger(s) provided at station(s). The central monitoring unit shall run the diagnostic software to generate alarm and exception reports.

**4.2 Data Logger Equipment:**

- 4.2.1 The equipment shall cater for minimum 512 digital inputs (in the form of potential free contacts) and 32 analog inputs. The system shall be expandable up to 4096 digital & 96 analog inputs by expansion/cascading the similar equipment.
- 4.2.2 The equipment shall have facility to interface with Remote Terminal Unit (RTU). The RTU shall have modules normally identical to that used in Data logger. A RTU shall cater for minimum 32 digital and 8 analog inputs. The RTU shall have its own processor & communication modules. RTU shall have facility to store at least 1 Lac events. RTU should be expandable up to 64 digital inputs and 16 analog inputs. The inputs of RTU can be taken as part of data logger system and the inputs of RTU shall be a part of the total capacity 4096 digital input and analog input capacity of 96. The programming of the individual digital & analog channels shall be controlled by the data loggers. It shall be possible to connect maximum of 4 RTUs. Alternatively, the RTU can exist with separate ID. There shall be no loss of data due to power failure.
- 4.2.3 RTU shall use standard current loop serial interface for data transmission. It shall be possible to connect RTU up to 3 Km. from main Data logger equipment.
- 4.2.4 Signal conditioning module shall convert analog signals like 230 VAC, 110 VAC, 110 VDC, 60 VDC, 24 VDC, 12VDC and axle counter RX voltages etc. to suitable level for recording. Normally all AC voltages shall be at commercial frequency of 50 HZ except for Axle counter which is at 5KHZ. When an analog channel is not connected, it shall not pick up any noise.

4.2.5 Configuration of analog channels may be as under;

| Channel | Nominal Voltage DC or AC (RMS) | Voltage Range for no alarm (adjustable) |
|---------|--------------------------------|---|
| 1       | 230 AC                         | 207- 253                                |
| 2       | 110 AC                         | 99- 121                                 |
| 3       | 110 AC                         | 99- 121                                 |
| 4       | 110 DC                         | 99- 121                                 |
| 5       | 60 DC                          | 55- 69                                  |
| 6       | 60 DC                          | 55- 69                                  |
| 7       | 24 DC                          | 22.5-28                                 |
| 8       | 24 DC                          | 22.5-28                                 |
| 9-16    | 1.0 AC,5KHz                    | -                                       |

Or as specified by purchaser.

- 4.2.6 Display shall be provided on the front panel of the data logger to display current status / faults/ alarms along with time stamp. It shall be possible to display faults/ alarms generated up to one week earlier on the panel. At least two row display shall be used with at least 16 characters in each row.
- 4.2.7 The equipment shall have real time clock for recording time at which the status of the particular information has changed. The real time clock on data logger should get synchronized with the central monitoring unit. The cascaded Data logger(s) shall also synchronize their clocks with the real time clock of master Data logger.
- 4.2.8 Opto-couplers may be provided to electrically isolate external digital inputs (relay contacts) from the equipment. Self-diagnostics shall be provided in the system. Any fault in the system shall generate error message in the system panel and generate alarm in the CMU.
- 4.2.9 The hardware structure of the system shall be modular.
- 4.2.10 Event logging facility for minimum 10 Lac events shall be provided in a Data logger. Data shall be recorded on first in – first out basis so that latest data is available in the system. There should be no loss of data from the data logger memory in case of power supply failure of data logger.
- 4.2.11 Scanning interval for digital inputs shall be less than 20 milliseconds. Change in status of digital signal shall only be recorded.

- 4.2.12 Scanning interval for analog signals like DC or AC supply voltage, temperature, axle counter RX voltage etc. shall be less than 1 second. Variation of more than 5% of the nominal value from the last recorded value, provided it has gone 5% beyond the nominal value, shall be recorded.
- 4.2.13 Accuracy of measurement of analog signals shall be better than 1% within  $\pm 40\%$  of nominal value.
- 4.2.14 The equipment shall have facility to receive serial data from external equipment like Electronic Interlocking, Integrated Power Supply etc. and record it with time stamp.
- 4.2.15 The software of the system shall be of approved type and written in a structured format so that the purchaser can reconfigure it, if required. The software shall have clear bifurcation between generic software and application software.
- 4.2.16 At least 6 serial ports shall be provided for communication with other data loggers, CMU, RTU, EI, IPS etc.
- 4.2.17 Power Supply: The system shall work on 24V DC (+20%, -30%). Railways will provide 24VDC input supply.
- 4.2.18 19" rack mountable and 3/4/6 U high cabinets made of aluminum of minimum thickness 2mm should be used for housing the PCB cards to achieve modular and ergonomic design for good maintainability. The cabinet should be powder coated. The front and backsides of the cabinets shall have the facility for locking the equipment.
- 4.2.19 Data Logger shall be capable of working with different transmission media like under ground telecom cable, microwave (Digital or Analog) & OFC. The provision of either in-built modem or external modem is acceptable. The data logger equipment will continuously check the modem status and give the necessary reset as required to eliminate modem hanging condition. The modem will be housed within the data logger cabinet. The data logger shall be compatible to the following media:
- (i) Main telecom cable.
  - (ii) Quad cable.
  - (iii) Analog channel of OFC, digital microwave or analog microwave.
  - (iv) 64 KBPS data channel on OFC or digital microwave.

- 4.2.20 Communication between data logger & RTU shall also be as per communication protocol mentioned in clause 4.3.9.
- 4.2.21 Cards and terminals required for up to minimum 1024 digital inputs 32 analog inputs, signal conditioning modules etc. shall be accommodated in one rack of 19" width.
- 4.2.22 For termination of external digital and analog inputs, international quality terminals of WAGO/ Phoenix etc. makes shall be used as per RDSO SPN/144. All wires should be neatly bunched in horizontal and vertical channels.

### **4.3      CENTRAL MONITORING UNIT (CMU):**

#### **4.3.1      SOFTWARE CONFIGURATION**

- 4.3.1.1 The database management system i.e. MS SQL server or Interbase shall be used to cater for basic function of Data loggers at CMU level. Only licensed software shall be used.

#### **4.3.2      HARDWARE CONFIGURATION**

- 4.3.2.1 Central monitoring unit shall be state of art PC ( of reputed brand ) based system working on commercial supply of 230VAC, 50Hz. The minimum configuration shall be as specified by RDSO from time to time. Presently minimum configuration must be as under:

- (i) Pentium 4 or equivalent processor 3 GHz, 256MB RAM, 2 × 20 GB HDD with disk mirroring, 1.44" FDD, SVGA colour monitor (17") sound card with speaker, 56 KBPS modem, key board, optical mouse, 10 / 100T LAN card, CD writer and inkjet printer .

- (ii) UPS with minimum 6 hours battery backup for central monitoring unit.

- (iii) Software tools.

- 4.3.2 Central monitoring unit shall have Graphical User Interface (GUI) based software and retrieve data from all Networked data loggers (up to 32) at various stations. It shall store data in standard data base files. The CMU shall also be capable of analyzing the data & generate reports & audio visual alarms on defined conditions. It shall be possible to compress the data and take backup on floppy.

- 4.3.3 Software used for analysis of data, prediction of faults etc. in central monitoring unit shall be of approved type and written in a structured format so that purchaser can reconfigure it, if required. A copy of software shall be supplied in CD.
- 4.3.4 It shall be possible to display the status of signalling gears at any selected time in graphic form for any selected station yard on the central monitoring unit.
- 4.3.5 It shall be possible to retrieve the stored data & simulate train movement on the central monitoring equipment.
- 4.3.6 It shall be possible to send commands to various Data loggers to activate audio, visual alarm or operate an electromagnetic relay.
- 4.3.7 It shall be possible to share data available in CMU by other PCs through available local area network where this data can be used for train charting / passenger information purpose.
- 4.3.8 Front End Processor (FEP) shall be provided to continuously retrieve data from station data loggers. FEP must have capacity to store 10 lac telegrams. It should have 6 ports.
- 4.3.9 The communication protocol for transmitting data and command between data logger and CMU is given in Annexure.

## **5 FUNCTIONAL REQUIREMENTS:**

- 5.1 The system shall generate audiovisual alarm in ASM's/ Signal Maintainer's room in the case of power supply failure (battery voltage low) or battery charger defective with acknowledgement facility.
- 5.2 Each data logger shall have it's own identity code which shall be transmitted along with data packet to central monitoring unit.
- 5.3 Events recorded at each station shall be continuously transmitted to central monitoring unit. Response time of data transfer shall not exceed 10 sec.
- 5.4 In case of loss of data, retransmission of data shall take place.
- 5.5 Data transfer rate shall be 57600 BPS with fallback facility to lower rates.

## **5.6 EXCEPTION REPORT:**

---



5.6.1 The Data logger equipment shall be capable of generating following exception reports;

- i) Battery Low voltage
- ii) Battery charger defective
- iii) Under wheel flashing of points
- iv) Signal lamp failure
- v) Blanking of Signals
- vi) Route section not released after passage of train due to track circuit failure.
- vii) Point Failure – point detection not available after set time period.
- viii) Track circuit failure
- ix) Fuse Blown OFF
- x) Timer not properly set for 120 Sec.
- xi) Sluggish relay operation
- xii) Signal cable low insulation
- xiii) Route not set when operation is valid.
- xiv) Push button stuck.
- xv) Signal over shoot.
- xvi) Wrong operation
- xvii) Axle Counter RX low level
- xviii) Bobbing of track, point, signal, crank handle, Level X-ing or Ground frame repeater relay
- xix) Point repeated operation
- xx) Non sequential shunting of tracks

5.6.2 The CMU shall be capable of generating following additional exception reports.

- i) Emergency cancellation of route
- ii) Panel failure due to power failure
- iii) Late start of a train (train operation)
- iv) Late operation of signals with respect to local trains (train operation)
- v) Route failure online indication with analysis of the stage at which it had failed.
- vi) Non-signal movement (train operation)
- vii) Total on time of lamp (to assess working life of signal lamp)
- viii) Total number of operations of the relay (to assess life of relay)
- ix) Emergency Point operation
- x) Emergency Route Release
- xi) Emergency Sub Route Release
- xii) Overlap release
- xiii) Emergency Crank Handle release

- xiv) Calling on operations
- xv) Slot operations
- xvi) Historical replay of events in a yard in graphical manner.
- xvii) Circuit progression. Railway shall provide logic for the same.
- xviii) Any other exception report.

5.7 Exception condition shall be stored in the data logger chronologically and displayed one by one on the front panel through a toggle switch.

5.8 Data loggers of all stations shall send status report to the Central monitoring unit continuously. Status information shall be processed at the central monitoring unit and audio visual alarm generated for the fault / alarm condition

## **6 TESTS AND REQUIREMENTS**

### **6.1 Conditions of Tests**

Unless otherwise specified all tests shall be carried out at ambient atmospheric conditions.

6.2 For inspection of material, relevant clauses of IRS: S 23 and RDSO/SPN/144 shall apply.

### **6.2.1 Test Equipment**

- i) Dual beam oscilloscope of 20 MHz bandwidth
- ii) Digital multimeters - 3.1/2 digit display with facility of diode & transistor testing with 1% accuracy
- iii) EPROM Programmer and UV eraser
- iv) Megger (500V)
- v) PC
- vi) Test jig
- vii) Any other test equipment considered necessary.

### **6.3 Type Tests**

6.3.1 The following tests shall constitute type tests:

- a) Visual inspection as per Clause 7.1
- b) Insulation Resistance tests as per Clause 7.2
- c) Card-level functional tests on all the cards.
- d) System level functional tests.

- e) Environmental/climatic tests as per Clause 7.3
- f) Applied High Voltage Test as per Clause 7.4

6.3.2 Any other tests shall be carried out as considered necessary by the purchaser.

6.3.3 Only one equipment shall be tested for this purpose. The equipment shall successfully pass all the type tests for proving conformity with this specification. If the equipment fails in any of the type tests, the purchaser or his nominee at his discretion, may call for another equipment/card(s) of the same type and subject it to all tests or to the test(s) in which failure occurred. No failure shall be permitted in the repeat test(s).

#### **6.4 Acceptance Tests**

6.4.1 The following shall comprise acceptance tests:

- a) Visual inspection (Clause 7.1).
- b) Insulation Resistance tests (Clause 7.2).
- c) System level functional tests.

6.4.2 Any other tests shall be carried out as considered necessary by the purchaser.

#### **6.5 Routine tests**

6.5.1 The following shall comprise the routine tests and shall be conducted by manufacturer on every equipment and the test results will be submitted to the inspection authority before inspection. The application software in proper format shall also be submitted to the inspection authority in advance.

- a) Visual inspection (Clause 7.1)
- b) Insulation Resistance tests (Clause 7.2)
- c) Card level functional test on all the cards.
- d) System level functional test.

6.5.2 Any other tests shall be carried out as considered necessary by the purchaser.

### **7 TEST PROCEDURE**

The test procedure shall be based on the system design. The methodologies to be adopted for various tests shall be decided taking into account the system design/configuration.

## **7.1 Visual Inspection**

The equipment shall be visually inspected to ensure compliance with the requirement of Clauses 3 to 5 of this specification. The visual inspection will broadly include –

### **7.1.1 System level checking:**

- Constructional details.
- Dimensional check .
- General workmanship.
- Configuration.
- Mechanical polarisation on cards .

### **7.1.2 Card level checking:**

- General track layout .
- Quality of soldering and component mounting.
- Conformal coating.
- Legend printing.
- Green masking.

### **7.1.3 Module level checking:**

- General shielding arrangement of individual cards.
- Indications and displays.
- Mounting and clamping of connectors.
- Proper housing of cards.

## **7.2 Insulation Resistance Test**

7.2.1 Insulation Resistance Test shall be conducted as per RDSO/SPN/144

## **7.3 Environmental / climatic tests**

7.3.1 Environmental / climatic tests shall be conducted as per RDSO/SPN/144

## **7.4 Applied High Voltage Test**

7.4.1 Applied High Voltage Test shall be conducted as per RDSO/SPN/144

## **8 QUALITY ASSURANCE**

- 8.1 All materials & workmanship shall be of good quality.
- 8.2 Since the quality of the equipment bears a direct relationship to the manufacturing process and the environment under which it is manufactured, the manufacturer shall ensure Quality Assurance Program of adequate standard.
- 8.3 Validation and system of monitoring of QA procedure shall form a part of type approval. The necessary Plant, Machinery and Test instruments as given below shall be available with the manufacturer.
- 8.3.1 Plant & Machinery:
- i) Ultrasonic cleaner/Aqueous cleaner for automatic cleaning
  - ii) Burn in chamber
  - iii) Anti-static assembly
  - iv) EPROM Programmer and UV Eraser
  - v) Microprocessor development system
  - vi) Computer aided design system
- 8.3.2 All test instruments as given in Cl. 6.2.1 shall be available with the manufacturer.
- 8.4 Along with the prototype sample for type test, the manufacturer shall submit the Quality Assurance Manual.

## **9 PACKING**

The equipment and its sub assemblies shall be packed in thermocole boxes and the empty spaces shall be filled with suitable filling material. Before keeping in the thermocole box, the equipment shall be wrapped with bubble sheet. The equipment shall be finally packed in a wooden case of sufficient strength so that it can withstand bumps and jerks encountered in a road/ rail journey.

## **10 INFORMATION TO BE SUPPLIED BY THE MANUFACTURER**

Following documents should be supplied along with the system:

- 10.1 Mechanical drawings of each sub-system/ rack.
- 10.2 Trouble shooting chart.
- 10.3 Installation and Maintenance Manual.

10.4 Pre-commissioning check list, DOs and DON'Ts of data logger system including RTU, CMU & FEP in the User's manual.

**11 INFORMATION TO BE SUPPLIED BY THE PURCHASER**

11.1 Total number of digital and analog inputs to be monitored calculated as under.

11.1.1 The tenderer should give number of digital inputs required by calculating the inputs from the list given below:

- a) All ECRs,
- b) All HRs, HHRs, DRs or equivalent
- c) All point operating relays NWRs, RWRs or equivalent
- d) All point indicating NWKRs, RWKRs or equivalent
- e) All buttons and knob relays
- f) All track and axle counter relays
- g) All timer repeater relays
- h) Intermediate interlocking relays which tenderer need to monitor through data-logger e.g. UCR, ASR, JSLR etc. or equivalent
- i) All relays related with emergency operations e.g. route cancellation, overlap cancellation, point operation under emergency, crank handle release, gate release etc.
- j) CH, GF, LX release and indication relays.
- k) All relays related with block instruments with or without axle counters and SM key.
- l) Any other relay required to be monitored.

11.1.2 Details of Analog inputs to be monitored in local area.

| Type of input  | No. of channels required |
|--|--------------------------|
| 230 V AC   |                          |
| 110 V AC   |                          |
| 12 V AC  |                          |
| 110 V DC   |                          |
| 60 V DC  |                          |
| 24 V DC  |                          |
| 18 V DC  |                          |
| 12 V DC  |                          |
| Axle counter evaluator input voltages (RX) (unit-wise) |                          |

|                   |  |
|-------------------|--|
| Any other voltage |  |
|-------------------|--|

- 11.1.3 Whether RTU is required for monitoring of the equipments at distant place, no. of digital and analog inputs required in RTU.

Details of analog inputs to be monitored from RTU should be given in the format as given below:

| Type of input<br>(Digital/Analog) | No. of<br>channels | Approximate distance from<br>data-logger |
|-----------------------------------|--------------------|--|
|-----------------------------------|--------------------|--|

- 11.2 Additional exception reports (other than those mentioned in para 5.6) to be generated.

- 11.3 List of functions (in addition those mentioned in para 3.10) to be monitored.

- 11.4 (a) Central monitoring equipment (CMU) required – Yes/ No.  
(b) FEP required – Yes/NO

If YES, indicate whether it is to be provided at the same station or at a remote place like control office etc.

- 11.5 Whether printer is required with data logger (at the station) : Yes/ No

## Annexure

### Communication Protocol for Data Logger Network

#### A.1 Scope

This Document completely details out the communication methods and protocols for the data logger. These methods and protocols are independent of the hardware of the data logger. The communication methods and protocols have been designed to bring out the maximum throughput from the network.

##### A.1.1 Overview

The data structure protocol for communication between the data loggers and CMU is explained in paras A.4, A.5 and A.6 of this Annexure.

#### A.2 Network

##### A.2.1 Topology

Ring Network topology has been adopted in this network. In Ring configuration the Data loggers are connected serially one to another. If 'n' number of Data loggers are in network then the first Data logger is connected to the second Data logger and second Data logger to third Data logger so on up to the 'nth' Data logger. Then the first and 'n th ' Data loggers will be connected to the Front End Processor ( FEP ) individually to make the network as closed ring. Each Data logger is connected with other Data loggers in either direction with 4 wire leased line modems. FEP is also connected through the modems to the first and last Data loggers. Since this type of configuration gives individual one to one communication between Data loggers, so event data can be placed into network immediately and simultaneously by all the Data loggers.

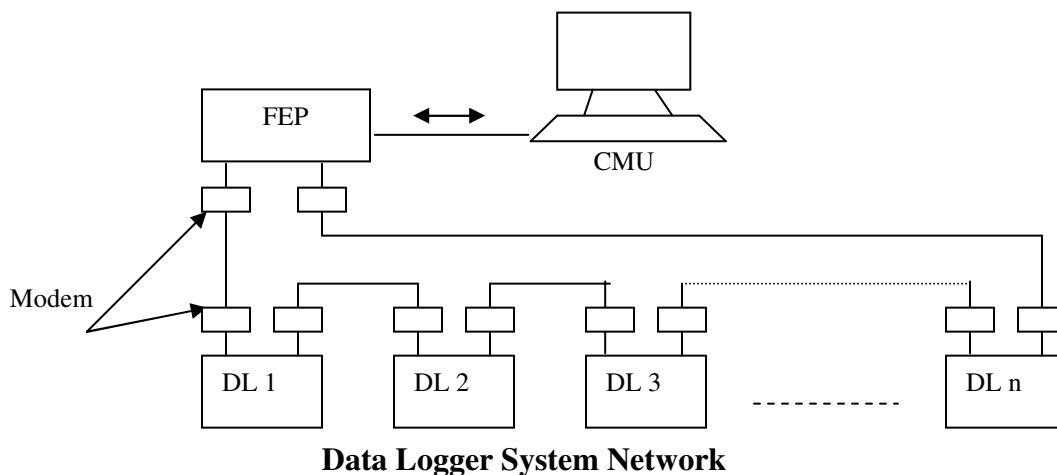



Direction A is data flow from Data logger n , n-1,.....1 - FEP.  
 Direction B is data flow from Data logger 1 , 2 ,.....n - FEP.

**A.2.2 Port**

- (i) Mode: Asynchronous
- (ii) Baud: 57600 bps
- (iii) Character Length: 8 bits
- (iv) Parity: none
- (v) Stop bits: 1

**A.3 Message Formats**

Two types of message formats have been implemented. One for Commands from CMU to any Data Logger / FEP and other is for event packets transmission in the network.

**A.3.1 Commands.**

Between CMU and Data Logger / FEP

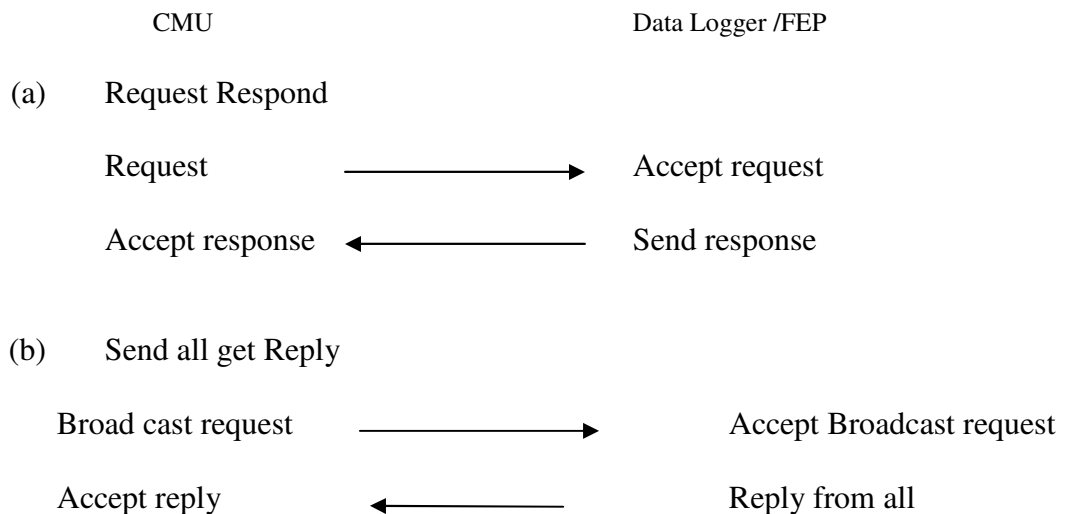

**A.3.2 Event Packets.**

Between two Data Loggers or Data Logger and FEP.

Data Logger n

Data Logger / FEP n-1

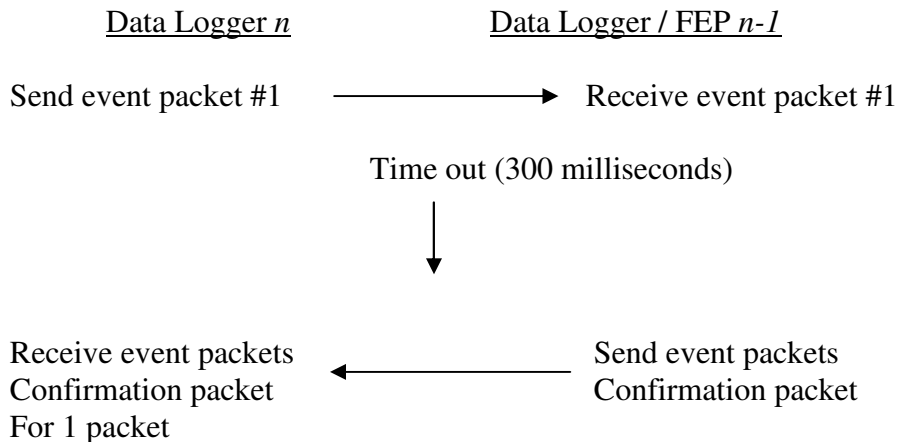
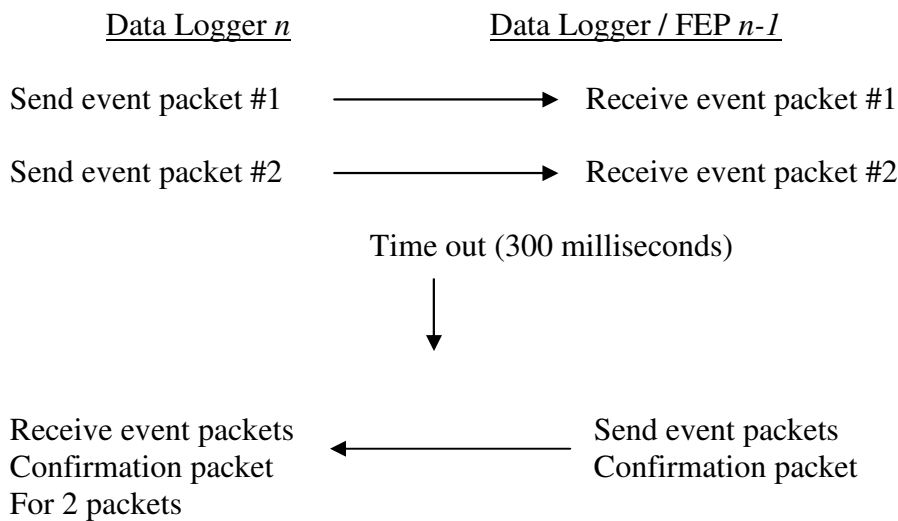
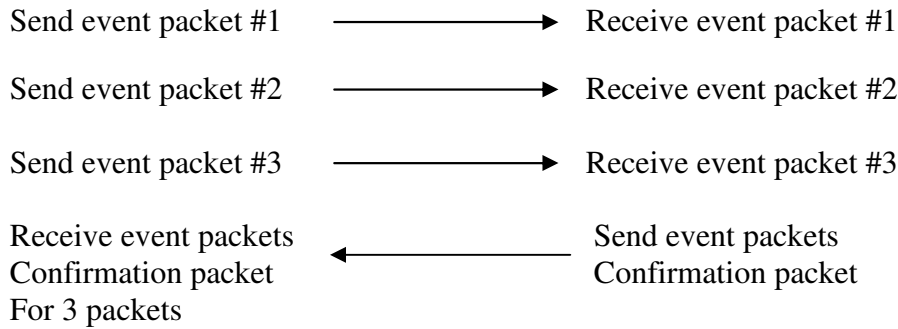

**A.3.3 Command and Event Flow**

**A.3.3.1 Command flow for request-respond**

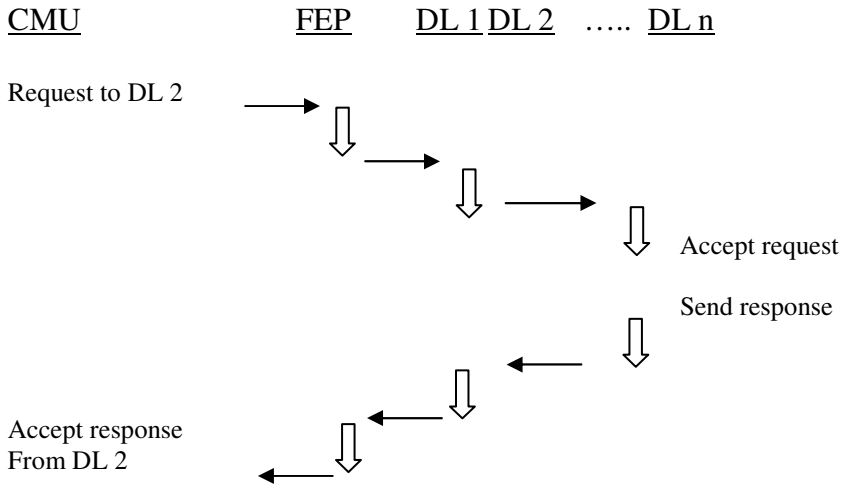

**A.3.3.2 Packet flow for event data in two directions**

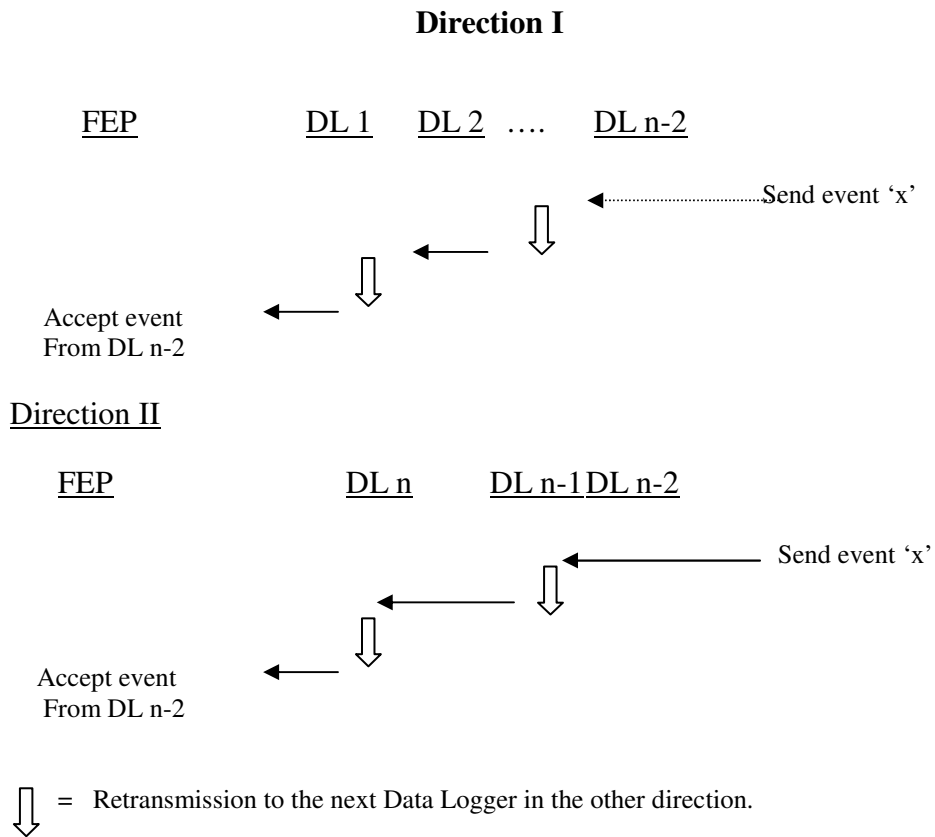

**A.3.3.3 Event Packets Communication:**

The event packets created in the DL will be sent immediately in both the directions. The event packets received from one direction is retransmitted to the other direction. The event packet is maintained in the buffer till it is acknowledged.

On failure of acknowledgement the event packets are tried again for transmission after the time out of 3 Seconds.

This is repeated and tried for three times with the same time-out of 3 Seconds. If acknowledgment is not received even after three trials, then time-out will be changed to 120 Seconds, thereafter it will be tried every 120 Seconds till it is acknowledged.

The acknowledgement for the event packets are sent for every three event packets received or if the time between received packet exceeds 300 milliseconds.

On receiving any event packet it is validated for CRC and Shift Checksum. If validity fails, no action is performed. For valid packets Data Logger will check for any duplication within the last 100 packets. If it is a duplicate packet then acknowledgement will be given but it will not be transmitted in the other direction. If it is a new packet then it will be placed in the buffer if space is available and acknowledge is sent back. If space is not available then buffer full command is sent back. Once the space is available then buffer free command is sent to reinitiate the packets transmission.

Once buffer-full command is received back for packet transmission then the Data logger will set itself to buffer full status and wait for a time lapse of 60 Seconds. On receiving the status of buffer free, the Data Logger will clear the buffer-full status and time lapses counts to initiate the transmission of packets.

At FEP, the received event packets from both the directions are buffered. These data will be sent to CMU whenever request received from CMU. Till then it is stored in buffer. These processes are illustrated with flow diagrams given below.

**A.3.3.4 Received Event Packet Processing**

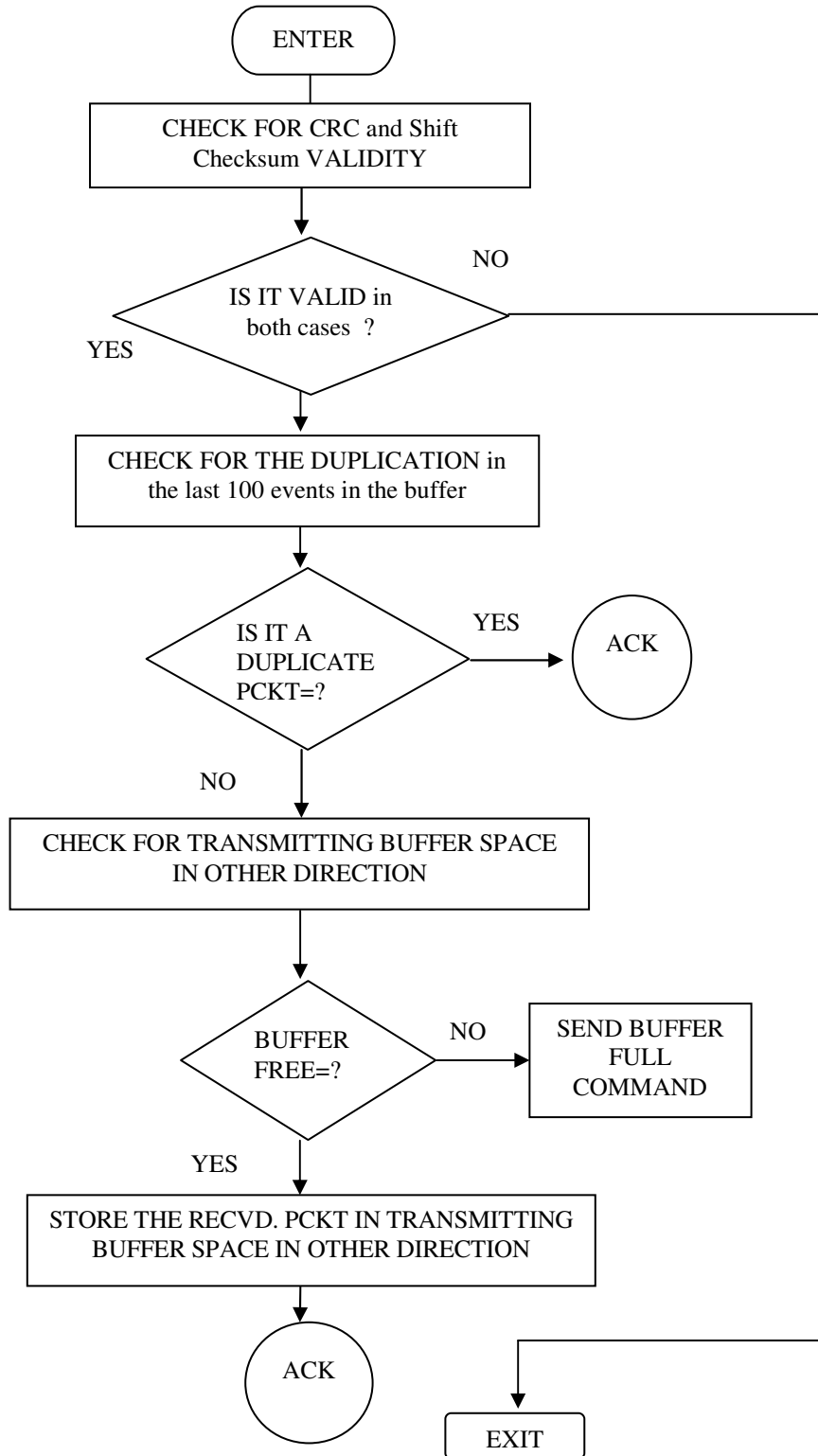

**A.3.3.5 Event Packet Transmission Process**

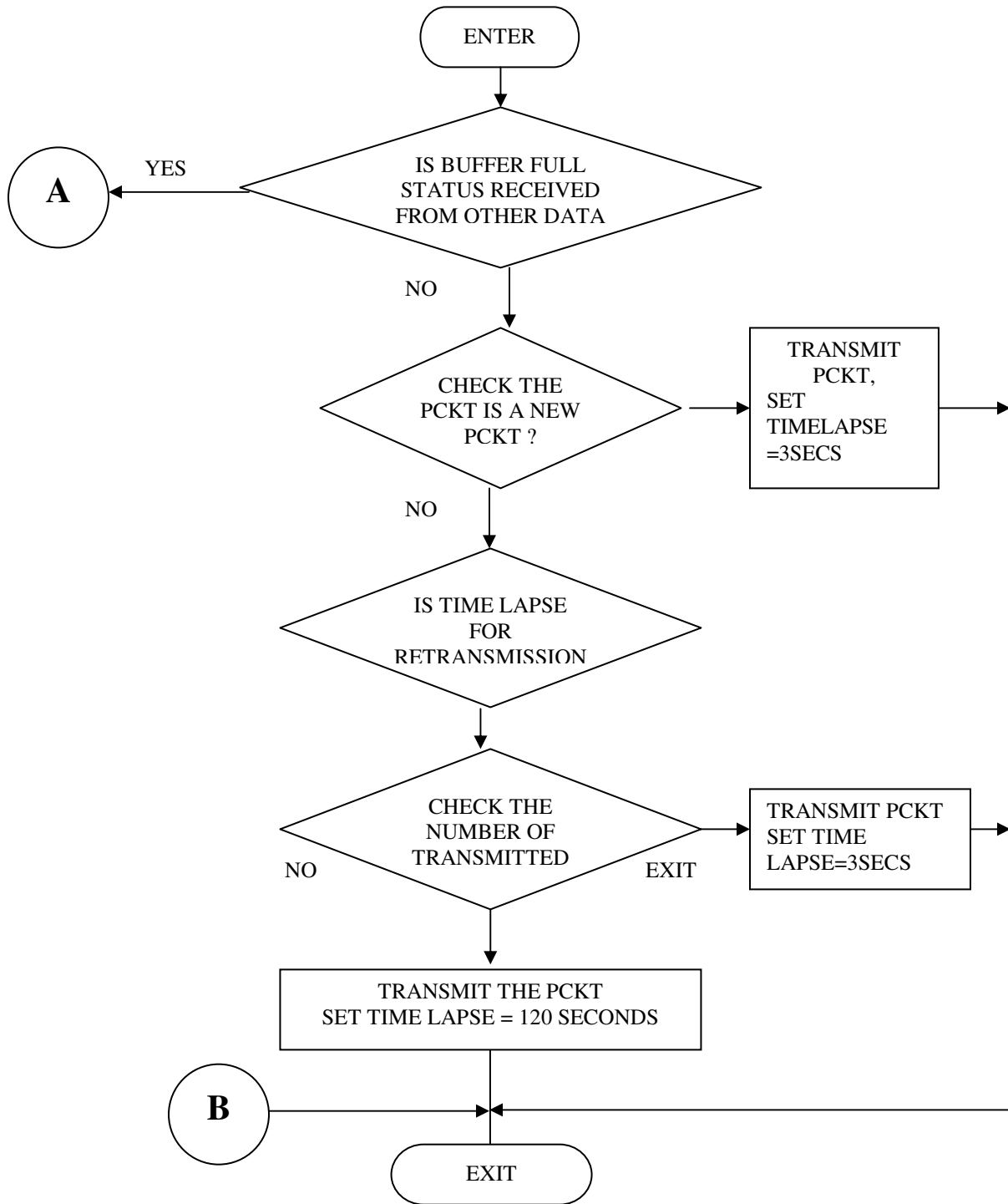

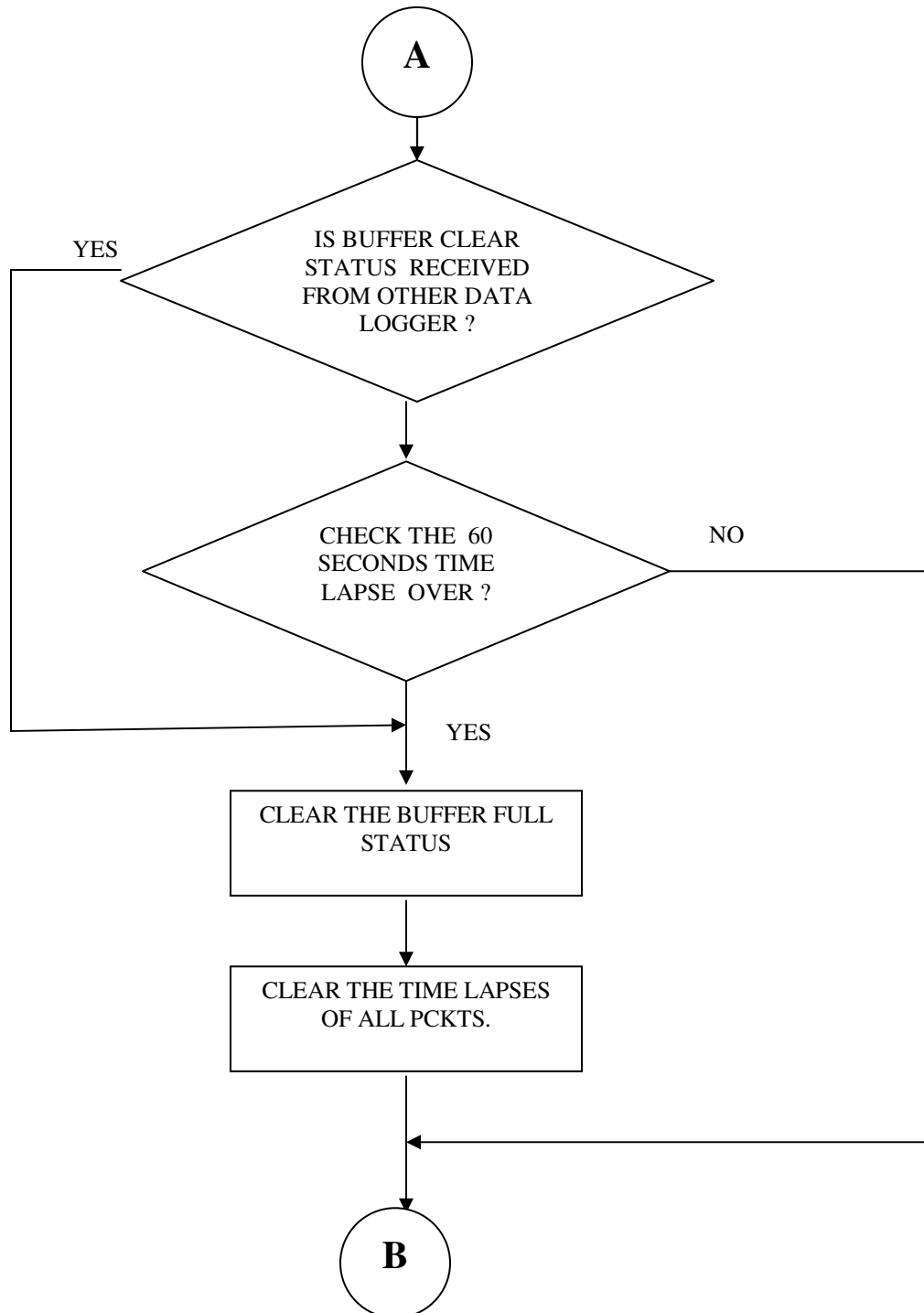

### A.3.3.6 Acknowledgement Process for Event Packet

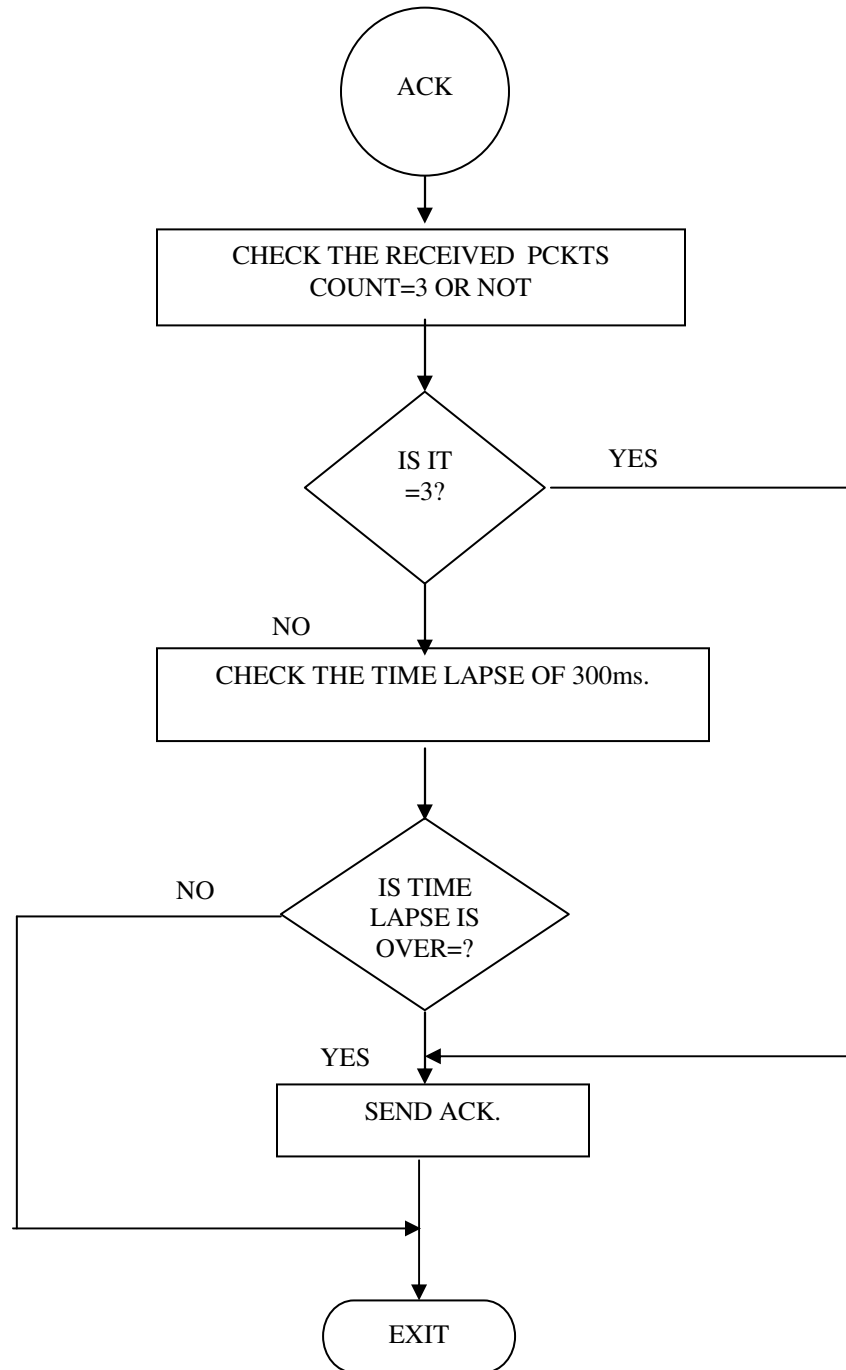



### **A.3.3.7    Commands Communication:**

Commands always originated from the CMU to facilitate control actions on any one or all the Data Logger/s in the network. Buffer full and Buffer free commands are the only commands originated by Data Loggers for control of event packets flow. The commands always work in the Request and Response style.

## A.4 EVENT PACKET

### A.4.1 EVENT PACKET FORMAT

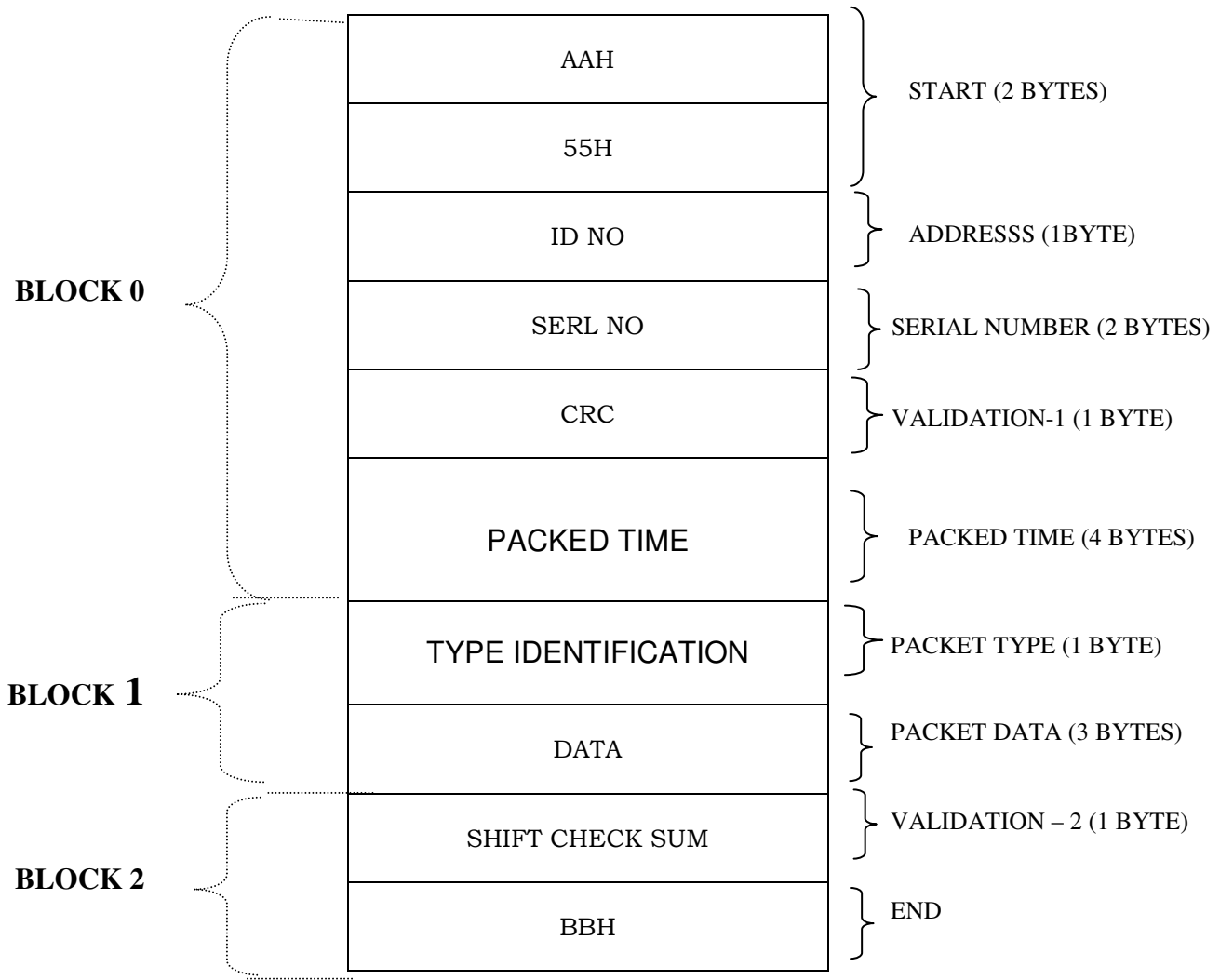

Event packet consists three blocks as shown in the above frame format.

- i) Block 0
- ii) Block 1
- iii) Block 2

**A.4.1.1 BLOCK 0: The size of the BLOCK 0 is 10 bytes. The structure of Block 0 is common for any type of event packet and it is having the following five fields.**

| Field Name         | Size in bytes |
|--------------------|---------------|
| <b>START</b>       | <b>2</b>      |
| <b>ID Number</b>   | <b>1</b>      |
| <b>Serial No.</b>  | <b>2</b>      |
| <b>CRC</b>         | <b>1</b>      |
| <b>Packed Time</b> | <b>4</b>      |

**START:** \$AA and \$55 are the start of the event packet.

**ID NO:** This is used for the identification of various devices like FEP, DATALOGGER and RTU.

The ID numbers allotted for each device is listed below.

| DEVICE      | ID RANGE  |
|-------------|-----------|
| FEP         | 00H       |
| RTU         | 01H - 40H |
| DATALOGGERS | 41H – 7FH |

Note: The ID numbers range from 80H to FFH are reserved.

**Serial Number:** It is the sequence number of packet. With this CMU will identify that it is receiving all the packets or not. Serial no will start from 0000H, when ever a packet is created count will be incremented by one, and will roll over to 0000H after reaching FFFFH.

**CRC :** This is a validation byte provided for the 11 bytes in the data packet from ID No to DATA fields.

**Calculation of CRC byte:**

Calculation of CRC byte using Microprocessor is time-consuming process. So look up table technique is being used. The lookup table will be prepared for all the combinations of words (16 bits each word). The total possible combinations are 65536 (0000H to FFFFH). So total 64K bytes of lookup-table is needed.

Calculation of the CRC byte for all 11 bytes as follows:

|    | <b>MSB</b> | <b>LSB</b>      | <b>RESULT</b> |
|----|------------|-----------------|---------------|
| 1  | ID No      | Serial No MSB   | CRC1          |
| 2  | CRC1       | Serial No LSB   | CRC2          |
| 3  | CRC2       | Time-1          | CRC3          |
| 4  | CRC3       | Time-2          | CRC4          |
| 5  | CRC4       | Time-3          | CRC5          |
| 6  | CRC5       | Time-4          | CRC6          |
| 7  | CRC6       | Type identifier | CRC7          |
| 8  | CRC7       | Data-1          | CRC8          |
| 9  | CRC8       | Data-2          | CRC9          |
| 10 | CRC9       | Data-3          | CRC10         |

**The CRC10 will be the CRC field in event packet.**

**Time-1, Time-2, Time-3 and Time-4 are 4 bytes of packed Time filed from MSB to LSB respectively.**

**Data-1, Data-2 and Data-3 are 3 bytes of DATA field from MSB to LSB respectively.**

First word will be framed by taking ID no as MSB and Serial No MSB as LSB. For this word the CRC byte will be taken from CRC lookup table is mentioned as CRC1 in the above table.

Second word will be framed by taking this resultant CRC byte (CRC1) as MSB and Serial No LSB as LSB. For this word the CRC byte will be read from CRC lookup table is mentioned as CRC2 in the above table.

This process will be repeated for 10 times as shown in the above table, the resultant byte (CRC10) is the final CRC. This will be placed in the event packet as CRC.

**PACKED TIME:**

**Time will be stored in the Packed Form.** This is a long word size and time will be calculated in multiples of 1/64 second. This long word will hold time for one year and even/odd year identification. In the long word least 31 bits will represent the time. The 32<sup>nd</sup> bit will be used to represent the year status, ‘1’ for odd year and ‘0’ for even year.

The equation to build packed time from the real time is given below.

$$\text{Packed time} = (\text{Days} \times 24 \times 60 \times 60 \times 64) + (\text{Hr} \times 60 \times 60 \times 64) + (\text{Mt} \times 60 \times 64) + (\text{Sec} \times 64).$$

Here Days = Number of completed days till present date  
 Hr = Hours  
 Mt = Minutes  
 Sec = Seconds

Example: Consider 12th March 2003, 21:16:24

Days = 70  
 Hr = 21  
 Mt = 16  
 Sec = 24

$$\begin{aligned} \text{Packed Time} &= (70 \times 24 \times 60 \times 60 \times 64 + 21 \times 60 \times 60 \times 64 + 16 \times 60 \times 64 + 24 \times 64) \\ &= 391973376 \text{ decimal} / 175D0A00 \text{ hexa} \end{aligned}$$

**A.4.1.2 BLOCK 1:**

**Block 1 size is 4 bytes. The values in the BLOCK 1 will vary depending upon the type of event packet. BLOCK1 is having the following fields.**

- a) **TYPE IDENTIFIER (1 bytes)**
- b) **DATA (3 bytes)**

**TYPE IDENTIFIER (TI):**

This is a byte-sized value and it indicates packet type. Each packet will have a unique type identifier. The below table shows various type identifiers.

| TI  | Details                      | USAGE      |
|-----|------------------------------|------------|
| 00H | Digital Record               | Compulsory |
| 01H | Analog Record                | Compulsory |
| 02H | Time Difference              | Compulsory |
| 03H | Time Write Low               | Compulsory |
| 04H | Communication Status Packets | Optional   |

|     |                              |            |
|-----|------------------------------|------------|
| 05H | Health Record                | Compulsory |
| 06H | Periodical All Inputs Status | Compulsory |
| 07H | All Inputs Status at Reset   | Compulsory |
| 08H | Reserved                     |            |
| 09H | Configuration Record         | Optional   |
| 0AH | Time Write High              | Compulsory |
| 0BH | Reserved                     |            |
| 0CH | Reserved                     |            |
| 0DH | Digital Fault                | Optional   |
| 0EH | Analog Fault                 | Optional   |
| 0FH | Reserved                     |            |
| 10H | Digital Chattering On        | Compulsory |
| 11H | Digital Chattering Off       | Compulsory |
| 12H | Modem Link Status            | Compulsory |
| 13H | Reserved                     |            |
| 14H | Reserved                     |            |
| 15H | Reserved                     |            |
| 16H | Reserved                     |            |
| 17H | Reserved                     |            |

**DATA:**

This field is having 3 bytes and the structure of these bytes will vary depending upon packet. All the packets are explained in the following sections.

**A.4.1.3 BLOCK 2:**

**BLOCK 2** size is 2 bytes. The structure of Block 2 is common for any type of event packet and it is having the following two fields.

| Field Name     | Size in bytes |
|----------------|---------------|
| Shift Checksum | 1             |
| End ( BBh )    | 1             |

**SHIFT CHECKSUM:**

This is also a validation byte provided for the 11 bytes in the data packet from ID No to DATA fields excluding CRC.

**Calculation of SHIFT CHECKSUM byte:**

In the calculation process, each byte in the record structure (leaving the CRC byte) will be rotated to left by one bit and then these bytes will be summed up to form the 'Shift checksum byte'.

It is explained in the given below example.

| Byte1 | Byte2 | Byte3 | Byte4 | Byte5 | Byte6 | Byte7 | Byte8 | Byte9 | Byte10 | Byte11 | Byte12 |
|-------|-------|-------|-------|-------|-------|-------|-------|-------|--------|--------|--------|
| 48H   | 00H   | 31H   | 10H   | 90H   | 00H   | C2H   | 13H   | 87H   | FFH    | FFH    | 31H    |

Byte 4 is CRC which is excluded in calculation.

CALCULATION

|         | Actual value<br>(in Hex ) | Actual value<br>(in Binary) | Rotated by 1 value<br>(in binary) | Shifter by 1<br>value (in hex) |
|---------|---------------------------|-----------------------------|-----------------------------------|--------------------------------|
| Byte 1  | 48H                       | 0100 1000                   | 1001 0000                         | 90H                            |
| Byte 2  | 00H                       | 0000 0000                   | 0000 0000                         | 00H                            |
| Byte 3  | 31H                       | 0011 0001                   | 0110 0010                         | 62H                            |
| Byte 5  | 90H                       | 1001 0000                   | 0010 0001                         | 21H                            |
| Byte 6  | 00H                       | 0000 0000                   | 0000 0000                         | 00H                            |
| Byte 7  | C2H                       | 1100 0010                   | 1000 0101                         | 85H                            |
| Byte 8  | 13H                       | 0001 0011                   | 0010 0110                         | 26H                            |
| Byte 9  | 87H                       | 1000 0111                   | 0000 1111                         | 0FH                            |
| Byte 10 | FFH                       | 1111 1111                   | 1111 1111                         | FFH                            |
| Byte 11 | FFH                       | 1111 1111                   | 1111 1111                         | FFH                            |
| Byte 12 | 31H                       | 0011 0001                   | 0110 0010                         | 62H                            |

Shift checksum or Resultant byte = 2DH

END : It is the Event packet END identifier.

**A.4.2 DIGITAL RECORD :**

This record will be created to indicate the change in status of the digital input.

Occurrence: This record will be created whenever a digital input changes its state (From ON to OFF or OFF to ON). Its record ID is **00H**.

|   |
|---|
| <b>BLOCK 0</b>                            |
| <b>BLOCK 1</b><br><b>TI - 00H (1Byte)</b> |
| <b>INPUT NUMBER(2Bytes)</b>               |
| <b>STATUS OF INPUT (1Byte)</b>            |
| <b>BLOCK 2</b>                            |

**INPUT NUMBER:** 1 TO 4096  
**STATUS OF INPUT :** 00h PICK UP  
 FFh DROP

**A.4.3 ANALOG RECORD :**

This record will be created whenever there is variation in the any of analog inputs.

Occurrence: This record will be created whenever the difference of previous recorded channel value and present scanned channel value of a particular input crosses the configured tolerance limit.

|   |
|---|
| <b>BLOCK 0</b>                            |
| <b>BLOCK 1</b><br><b>TI - 01H (1Byte)</b> |
| <b>CHANNEL VALUE(2Byte)</b>               |
| <b>CHANNEL NUMBER (1Byte)</b>             |
| <b>BLOCK 2</b>                            |

**A.4.3.1 CHANNEL VALUE :** 0 TO 4095 (Value 4095 is equivalent to Maximum possible Channel value for that input). The nominal voltages and their corresponding maximum voltages are shown in the below table.

| Nominal voltage | Maximum voltage | Maximum value |
|-----------------|-----------------|---------------|
| 230V AC         | 330V AC         | 4095          |
| 110V AC         | 170V AC         | 4095          |
| 110V DC         | 170V DC         | 4095          |
| 60V DC          | 90V DC          | 4095          |
| 24V AC          | 50V DC          | 4095          |
| 24V DC          | 50V DC          | 4095          |
| 18V DC          | 50V DC          | 4095          |
| 12V DC          | 25 VDC          | 4095          |
| 150mv           | 150 mv          | 4095          |
| 3V or 2V, 5KHZ  | 3000mv          | 4095          |
| 6V DC           | 10V DC          | 4095          |



**A.4.3.2 CHANNEL NUMBER:** 1 TO 96

The temperature record will also be created with the same analog record ID with channel number as 00h. The channel value MSB made 00 and LSB gives the temperature measured.

**A.4.4 TIME DIFF ID:**

To notify the difference between the packed time and with RTC chip time.

Occurrence: This record will be created whenever there is a difference in packed time and RTC chip time. The data logger compares the chip time with the packed time periodically and to record the difference if any

|  |              |
|--|--------------|
| <b>BLOCK 0</b>                         |              |
| <b>BLOCK 1</b><br><b>TI - 02H (1B)</b> |              |
| <b>STATUS BYTE (1B)</b>                |              |
| <b>DIFFERNCE TIME</b>                  | <b>VALUE</b> |
| <b>(2B)</b>                            |              |
| <b>BLOCK 2</b>                         |              |

**STATUS BYTE:**

00H if RTC Time > Packed Time

FFH if RTC Time < Packed Time

DIFFERNCE TIME VALUE: RTC Time ~ Packed Time

**A.4.5 TIME WRITE :**

This record will be created whenever time set command was sent from CMU.

Occurrence: This record is created whenever time was set from CMU, two records were created, one for lower 3 bytes and another for upper 3 bytes of packed time that has been sent from the CMU. These two records differ in record Id, for the lower 3 bytes it is 03H. For the higher three bytes it is **0AH**.

|   |
|---|
| <b>BLOCK 0</b>                                  |
| <b>BLOCK 1</b><br><b>TI - 03h / 0Ah (1Byte)</b> |
| <b>Set Time (3Byte)</b>                         |
| <b>BLOCK 2</b>                                  |

**A.4.6 Communication Status Packets:**

These records were created to log network status for later analysis. the network communication health status.

Occurrence: These records will be created for every 68 minutes approximately.

|  |
|--|
| <b>BLOCK 0</b>                         |
| <b>BLOCK 1</b><br><b>TI - 04H (1B)</b> |
| <b>PACKETS COUNT (2B)</b>              |
| <b>SERIAL NUMBER (1B)</b>              |
| <b>BLOCK 2</b>                         |

**A.4.6.1 PACKET COUNT:**

Transmitted packets (or) Received packets (or) Pending packets (or) Duplication packets (or) Fail packets for two network ports.

**A.4.6.2 SERIAL NUMBER:** It specifies the type of Packets count.

| Serial Number | Details                                  |
|---------------|--|
| 01h           | Transmitted Packets Count (Direction-A)  |
| 02h           | Receive Fail Packets Count (Direction-A) |
| 03h           | Pending Packets Count (Direction-A)      |
| 04h           | Received Packets Count (Direction-A)     |
| 05h           | Transmitted Packets Count (Direction-B)  |
| 06h           | Receive Fail Packets Count (Direction-B) |
| 07h           | Pending Packets Count (Direction-B)      |
| 08h           | Received Packets Count (Direction-B)     |

|     |   |
|-----|---|
| 0dh | Duplication Packets Count (Direction-A) |
| 0eh | Duplication Packets Count (Direction-B) |

**A.4.7 HEALTH RECORD:**

This record will be created to notify the health of data logger to the CMU.

Occurrence: This record will be created for every one minute if any other record is not created.

|  |
|--|
| <b>BLOCK 0</b>                         |
| <b>BLOCK 1</b><br><b>TI - 05H (1B)</b> |
| <b>DUMMY BYTES (3BH)</b>               |
| <b>BLOCK 2</b>                         |

DUMMY BYTES: 00H

**A.4.8 Periodical All Inputs Status:**

In these records the status of all the digital inputs will be sent. So as the CMU can synchronize with the latest input status.

Occurrence: These records are created for every 34 minutes approximately and also on request of the CMU. The number of records created will depend upon the number of inputs configured. In each record, status of 16 inputs will be sent. Each inputs status can be 0 or 1('0' for pickup and '1' for drop). If the number of inputs configured is 512, 32 records will be created. The configuration should be in the multiples of 512 inputs. The 1st record will have inputs of 1 to 16, 2nd record will have 17 to 32 and so on up to the total number of inputs.

|    |    |    |    |    |    |    |    |    |    |    |    |    |    |    |    |    |
|----|----|----|----|----|----|----|----|----|----|----|----|----|----|----|----|----|
| BI | B1 | B1 | B1 | B1 | B1 | B1 | B0 | B0 | B0 | B0 | B0 | B0 | B0 | B0 | B0 | B0 |
| T  | 5  | 4  | 3  | 2  | 1  | 0  | 9  | 8  | 7  | 6  | 5  | 4  | 3  | 2  | 1  | 0  |
| IP |    |    |    |    |    |    |    |    |    |    |    |    |    |    |    |    |
| N  |    |    |    |    |    |    |    |    |    |    |    |    |    |    |    |    |
| O  | 16 | 15 | 14 | 13 | 12 | 11 | 10 | 9  | 8  | 7  | 6  | 5  | 4  | 3  | 2  | 1  |

|  |
|--|
| <b>BLOCK 0</b>                         |
| <b>BLOCK 1</b><br><b>TI - 06H (1B)</b> |
| <b>STATUS (2B)</b>                     |
| <b>SERIAL NUMBER(1B)</b>               |
| <b>BLOCK 2</b>                         |

**STATUS:** Status of a set of 16 inputs

**SERIAL NUMBER:** 00h-FFh

For the first 1 to 16 inputs 00h is given as serial number and continued up to FFh for the inputs 4096.

**A.4.9 All Inputs Status At RESET:**

These records have been created at the time of Data Logger Reset. This is identical to the **Periodical All Inputs Status** except the type identifier.

Occurrence: These records will be created when ever the data logger resets.

|  |
|--|
| <b>BLOCK 0</b>                         |
| <b>BLOCK 1</b><br><b>TI - 07H (1B)</b> |
| <b>STATUS (2B)</b>                     |
| <b>SERIAL NUMBER(1B)</b>               |
| <b>BLOCK 2</b>                         |

**A.4.10 Configuration Record:**

This record will be created to store the all configurations of the Data Logger.

Occurrence: This record will be created whenever data logger is reset/powerd on. This record will also be sent for every 34 minutes along with the Periodical all input status packets.

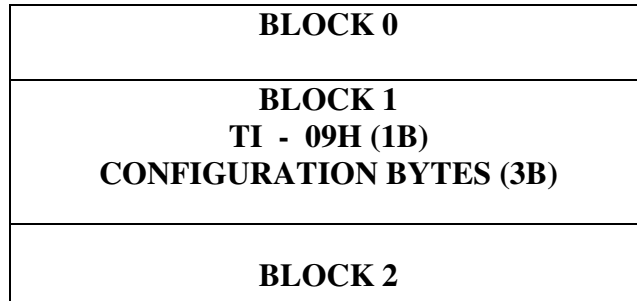

**CONFIGURATION BYTES:**

Byte1: Higher nibble (B7-B4) contain version value  
 Lower nibble will give Revision value.

Byte2: Bit 7 is to differentiate data logger from relay hut.  
 If it is '1', it is a Data logger  
 If it is '0', it is a relay hut.

Bit 6 is not used.  
 Bit 5 is not used.

Bit 4 is to indicate whether analog channels are enabled or not.  
 If '0', analog channels are disabled.  
 If '1', analog channels are enabled.

Bit 3 is not used .

Bits B2,B1, B0 will indicate the digital inputs configuration.

| B2 | B1 | B0 | Number of digital inputs configured |
|----|----|----|-------------------------------------|
| 0  | 0  | 0  | 512                                 |
| 0  | 0  | 1  | 1024                                |
| 0  | 1  | 0  | 1536                                |
| 0  | 1  | 1  | 2048                                |
| 1  | 0  | 0  | 2560                                |
| 1  | 0  | 1  | 3072                                |
| 1  | 1  | 0  | 3584                                |
| 1  | 1  | 1  | 4096                                |

Byte3: Reserved

**A.4.11 DGTLFALT\_RECID:**

This record will be created whenever the digital fault sequence occurs.  
 No specific data format is defined since the digital fault sequence is dependent on local PC.

Occurrence: This record is created, whenever the predefined sequence of operations will occur.

|   |
|---|
| <b>BLOCK 0</b>  |
| <b>BLOCK 1</b><br><b>TI - 0DH (1Byte)</b><br><b>DATA (3Bytes)</b> |
| <b>BLOCK 2</b>  |

**A.4.12 ANLGFALT\_RECID:**

This record will be created to indicate that the analog channels exceeded configured safe limits.

Occurrence: This record is created whenever an analog channel crosses the configured minimum or maximum channel limits.

This record identical to analog record except type identifier.

|   |
|---|
| <b>BLOCK 0</b>  |
| <b>BLOCK 1</b><br><b>TI - 0EH (1Byte)</b><br><b>CHANNEL VALUE (2Bytes)</b><br><b>CHANNEL NUMBER (1Byte)</b> |
| <b>BLOCK 2</b>  |

**CHANNEL VALUE:**    0 TO 4095.

**CHANNEL NUMBER:** 1 TO 64

B7- '1' THEN FAULT IS DUE TO EXCEEDING MAX. VALUE  
 '0' THEN FAULT IS DUE TO FALLING BELOW MIN. VALUE  
 B6 TO B0 – INDICATE THE CHANNEL NUMBER.

**A.4.13 CHTRON\_RECID:**

This record is created whenever any relay is chattering.

Occurrence: This record will be created whenever digital input changes from NORMAL state to CHATTERING state.

A digital input is said to be in chattering state, if its status changes by 8 times or more in 4 seconds. Normal state is the state where the input status does not change so.

|   |
|---|
| <b>BLOCK 0</b>  |
| <b>BLOCK 1</b><br><b>TI - 10H (1Byte)</b><br><b>INPUT NUMBER (2Bytes)</b><br><br><b>INPUT STATUS (1Bytes)</b> |
| <b>BLOCK 2</b>  |

**INPUT NUMBER :** 01 TO 4096

**INPUT STATUS:** No significance

**A.4.14 CHTROFF\_RECID:**

This record is created whenever any relay is normalized from chattering.

Occurrence: This record will be created whenever digital input changes from CHATTERING state to NORMAL state.

|  |
|--|
| <b>BLOCK 0</b>   |
| <b>BLOCK 1</b><br><b>TI - 11H (1Byte)</b><br><b>INPUT NUMBER (2Bytes)</b><br><b>INPUT STATUS (1Byte)</b> |
| <b>BLOCK 2</b>   |

**INPUT NUMBER :** 01 TO 4096

**INPUT STATUS:**

00H- PICKUP  
FFH- DROP

**A.4.15 Modem Link Status**

This record will be created whenever the modem establishes or losses the link with the other modem.

Occurrence: This record will be created whenever 'Carrier Detect' bit of the modem changes its state.

|  |
|--|
| <b>BLOCK 0</b>   |
| <b>BLOCK 1</b><br><b>TI - 12H (1Byte)</b><br><b>CD STATUS (1Byte)</b><br><b>PORT NUMBER (1Byte)</b><br><br><b>00H (1B)</b> |
| <b>BLOCK 2</b>   |

**PORT NUMBER :**

01H- Direction A  
02H- Direction B

**CD STATUS :**

00h- 'CD' NOT EXISTING  
FFh- 'CD' EXSISTING



**A.5 ACKNOWLEDGEMENT PACKET**

The Acknowledgement packet structure is given below.

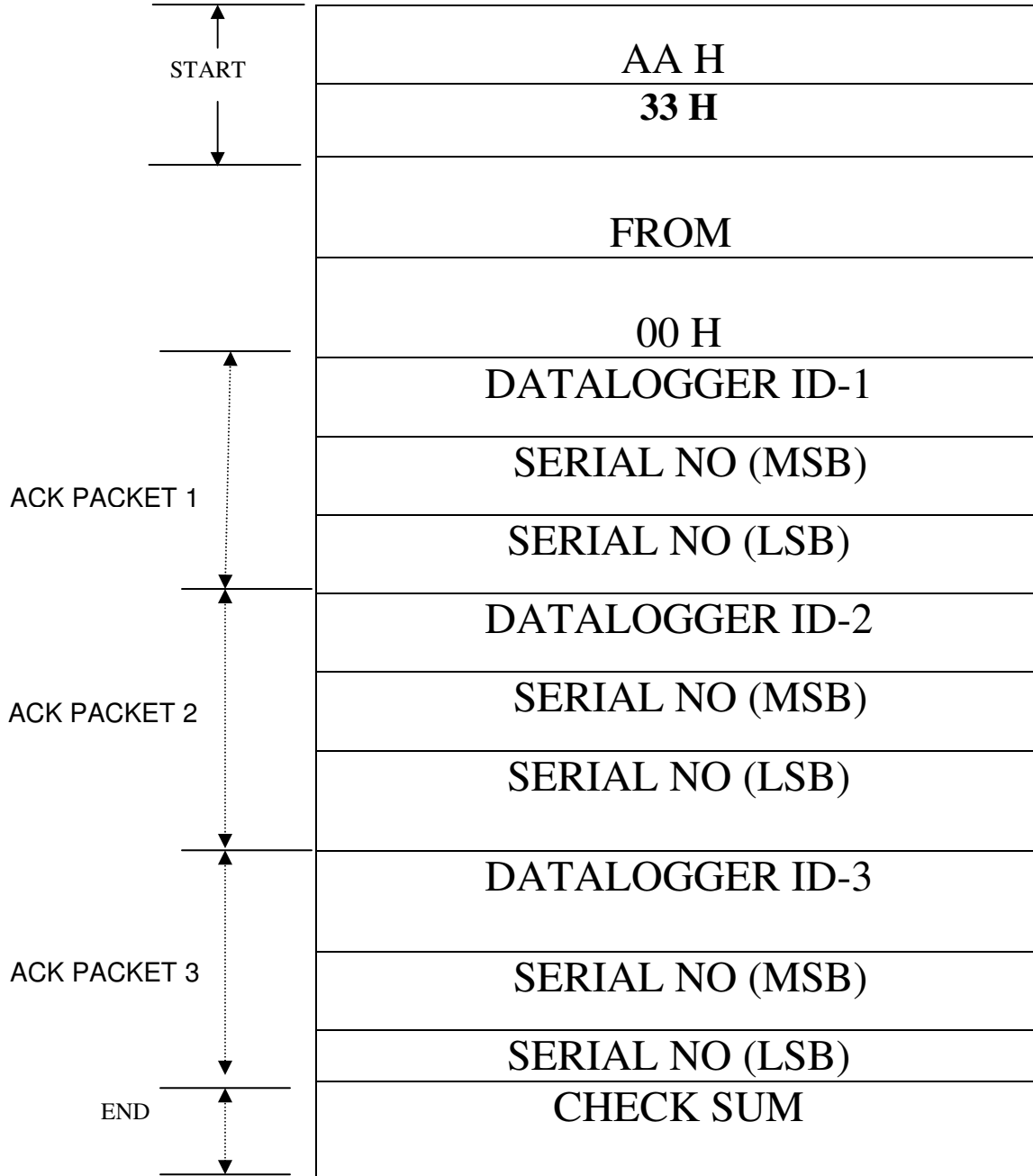

**START:** AAH, 33H are the start identifiers.

**FROM:** Indicates the data logger ID from which the acknowledgement is sent.

**DATALOGGER ID-1:** Signifies the DL-ID in the first event packet received.

**DATALOGGER ID-2:** Signifies the DL-ID in the second event packet received.

**DATALOGGER ID-3:** Signifies the DL-ID in the third event packet received.

**SERIAL NO:** Signifies the serial number in the received event packet.

**CHECKSUM:** Signifies the validation Byte for this acknowledgement packet. It is the 2's complement of modulo sum of the 11 bytes from "FROM" field to Serial Number LSB of third event packet.

The length of the frame is always fixed to 14 bytes in spite of the number of event packets received are less than 3 also. In that case the other acknowledges are filled with '00h'.

## A.6 Command Format

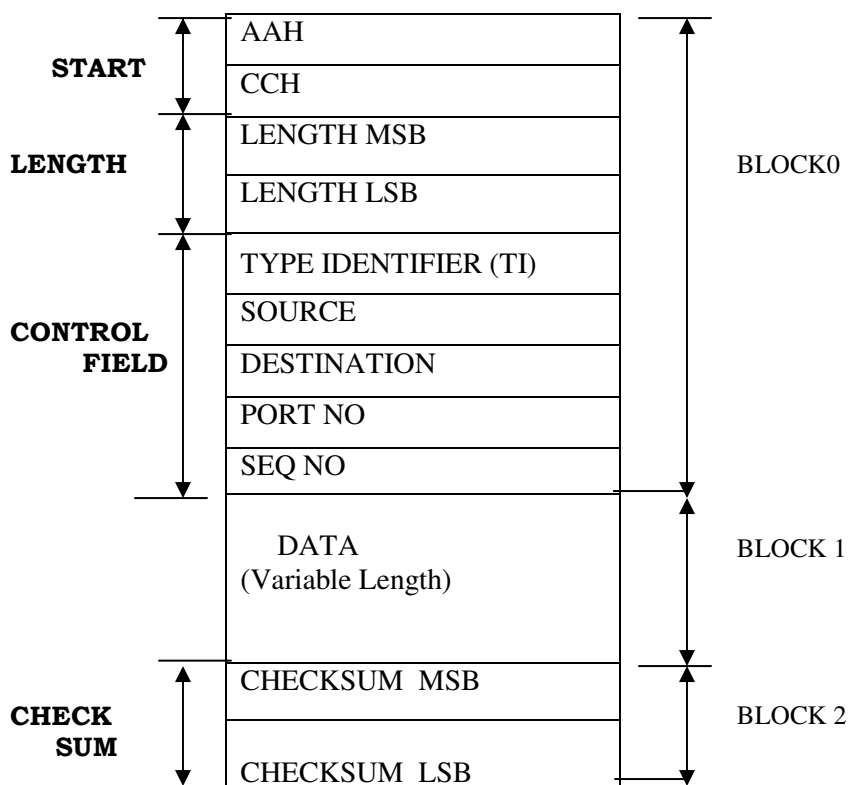

**A.6.1 BLOCK0:**

**START:** Every command frame will be started with these two identifiers. The identifiers are

1. AAH
2. CCH

**LENGTH:** The LENGTH is represented in two bytes as 16-bit value. It defines the no. of bytes in between Type identifier(TI) and Checksum Lsb Inclusive of both.

**CONTROL FIELD:**

- A. TYPE IDENTIFIER, B. SOURCE, C. DESTINATION, D. PORT NO,  
E. SEQ NO

A. TYPE IDENTIFIER(TI):

Type Identifier will represent different commands. Also it represent the acknowledgement by OR with 40h for the command received.

| Type Identifier Range | Details          |
|-----------------------|------------------|
| 00h - 7Fh             | Reserved         |
| 80h - BFh             | Commands         |
| C0h - FFh             | Acknowledgements |

B. SOURCE:

This byte signifies from where the command is originated.

C. DESTINATION:

This byte indicates the destination to where the command has to reach.

For above two control bytes the identifications are

- i. CMU: The identification for CMU was FFh
- ii. FEP: Identification for FEP was 00h
- iii. DL: Identification range was 41h to 7Fh

For any command, If the destination byte is 'FFH', then that command will be treated as a Global command.

Whenever a data logger receives a command, it will check the destination byte for FFH, if it is FFH, then it will serve the command and will send it to next data

logger.

If the destination byte is not FFH, then the data logger will check it with it's own ID. If it found to be equal then it will serve the command. If it is not equal, then it will send that command to the next data logger.

**D. PORT NO:**

FEP is having 3 Ports in 3 directions. CMU can send the command in any direction/s by placing '1' in the relevant bit/s in the field.

Byte structure:

|         |    |    |    |    |    |       |       |       |
|---------|----|----|----|----|----|-------|-------|-------|
| Bit pos | B7 | B6 | B5 | B4 | B3 | B2    | B1    | B0    |
| Value   | 0  | 0  | 0  | 0  | 0  | Port3 | Port2 | Port1 |

- 1 – Selection of port
- 0 – Ignoring of port

**E. SEQUENCE NO:**

This byte is generated by the CMU. And CMU anticipates the same byte should be echoed in the acknowledgement command, other wise CMU treats acknowledgement as invalid.

**Type-Identifiers:**

| Type-Identifie | Command                  | Description   |
|----------------|--------------------------|---|
| 80H            | Link check               | For checking link in b/w CMU & DL.  |
| 81H            | Data Request             | Request DL for Data in Stand alone mode. Ignored in network ports.                |
| 82H            | Upload result            | Ack. To the above Data Request Command.   |
| 83H            | Read Time                | Read time from DATA LOGGER  |
| 84H            | Write Time               | Writing time into DATA LOGGER   |
| 85H            | Buffer Free              | Buffer free between Data Loggers  |
| 86H            | Reserved                 |   |
| 87H            | Reserved                 |   |
| 88H            | Reserved                 |   |
| 89H            | Reserved                 |   |
| 8AH            | Reserved                 |   |
| 8BH            | All I/P Status           | Request For Creating All inputs Records   |
| 8CH            | Modem reset              | Request For Modem Reset (Res)   |
| 8DH            | Reserved                 |   |
| 8EH            | Reserved                 |   |
| 8FH            | Buffer full              | Buffer full between Data Loggers  |
| 90H            | Set transmitting pointer | For setting the Transmitting pointer of the required port to the required record. |

|     |                      |   |
|-----|----------------------|---|
| 91H | Receive relay status | Requesting 1-8 relay status from data logger  |
| 92H | Send relay status    | Sending 1-8 relay status to the data logger   |
| 93H | Receive relay status | Requesting 9-16 relay status from data logger |
| 94H | Send relay status    | Sending 9-16 relay status to the data logger  |
| 95H | Reserved             |   |

**Link check:**

|  |
|--|
| <p><b>BLOCK 0</b><br/> TI – 80H<br/> RECORD LENGTH = 07H</p> |
| <p><b>BLOCK 1</b><br/> {No DATA BYTE is available}</p>       |
| <p><b>BLOCK 2</b></p>  |

**Acknowledgement for Link Check:**

|  |
|--|
| <p><b>BLOCK 0</b><br/> TI – C0H<br/> RECORD LENGTH = 07H</p> |
| <p><b>BLOCK 1</b><br/> {No DATA BYTE is available}</p>       |
| <p><b>BLOCK 2</b></p>  |

**Data Request:**

|  |
|--|
| <p><b>BLOCK 0</b><br/> TI – 81H<br/> RECORD LENGTH = 07H</p> |
| <p><b>BLOCK 1</b><br/> {No DATA BYTE is available}</p>       |
| <p><b>BLOCK 2</b></p>  |

This command is used to receive event records of the Data Logger in to local PC.

**Acknowledgement for DATA REQUEST:**

|  |
|--|
| <p><b>BLOCK 0</b><br/> TI – C1H<br/> RECORD LENGTH = N+07H</p> |
| <p><b>BLOCK 1</b><br/> (N Bytes)<br/> {Length is Variable}</p> |
| <p><b>BLOCK 2</b></p>  |

In the acknowledgement frame Data Logger can send event data of 10 records maximum to local PC. Event packets are identical with 12 bytes in length as specified in event packet format without Start, Shift Checksum and End identifier.

If data is not available N becomes 0.  
Number of Bytes is: N

**UpLoad Result:**

|  |
|--|
| <p><b>BLOCK 0</b><br/> TI – 82H<br/> RECORD LENGTH = 07H</p> |
| <p><b>BLOCK 1</b><br/> <b>NO DATA BYTES</b></p>              |
| <p><b>BLOCK 2</b></p>  |

After successful event data transfer from data logger CMU will send this command.

**TIME READ:**

|  |
|--|
| <p><b>BLOCK 0</b><br/> TI – 83H<br/> RECORD LENGTH = 07H</p> |
| <p><b>BLOCK 1 {No DATA BYTE is available}</b></p>            |
| <p><b>BLOCK 2</b></p>  |

**Acknowledgement for TIME READ:**

|  |
|--|
| <p><b>BLOCK 0</b><br/> TI – C3H<br/> RECORD LENGTH = 0DH</p>   |
| <p><b>BLOCK 1</b><br/> (6 bytes)<br/> Byte 1-4 : Packed Time<br/> Byte 5: Year MSB (Hex)<br/> Byte 6: Year LSB (Hex)</p> |
| <p><b>BLOCK 2</b></p>  |

**TIME WRITE:**

|   |
|---|
| <p><b>BLOCK 0</b><br/> TI – 84H<br/> RECORD LENGTH = 0DH</p>  |
| <p><b>BLOCK 1</b><br/> (6 bytes)<br/> Byte1-4 : Packed Time<br/> Byte 5: Year MSB (HEX)<br/> Byte 6: Year LSB (HEX)</p> |
| <p><b>BLOCK 2</b></p>   |

**Acknowledgement for TIME WRITE:**

|  |
|--|
| <p><b>BLOCK 0</b><br/> TI – C4H<br/> RECORD LENGTH = 08H</p> |
| <p><b>BLOCK 1 (1 Byte)</b><br/> Byte 1: STATUS BYTE</p>      |
| <p><b>BLOCK 2</b></p>  |

STATUS BYTE:      00 Time Write Success  
                         01 Time Write Fail

**BUFFER FREE:**

|  |
|--|
| <p><b>BLOCK 0</b><br/> TI – 85H<br/> RECORD LENGTH = 07H</p> |
| <p><b>BLOCK 1</b><br/> No Data</p>                           |
| <p><b>BLOCK2</b></p>   |

This command will be sent between data loggers, to intimate other data logger that its buffer is free now and it can take event data.



**ALL INPUT STATUS:**

|  |
|--|
| <p><b>BLOCK 0</b><br/> TI – 8BH<br/> RECORD LENGTH = 07H</p> |
| <p><b>BLOCK 1</b><br/> {No DATA BYTE is available}</p>       |
| <p>BLOCK2</p>  |

**Acknowledgement for ALL INPUT STATUS:**

|  |
|--|
| <p><b>BLOCK 0</b><br/> TI – CBH<br/> RECORD LENGTH = 07H</p> |
| <p><b>BLOCK 1</b><br/> (1Byte)<br/> Byte1: Success 00</p>    |
| <p>BLOCK2</p>  |

This command will be sent whenever all digital input status need to be updated in CMU. This command will trigger all input event packets to be generated and the command will be acknowledged with above frame.

**MODEM RESET:**

|  |
|--|
| <p><b>BLOCK 0</b><br/> TI – 8CH<br/> RECORD LENGTH = 08H</p>                                 |
| <p><b>BLOCK 1 (1 Byte)</b><br/> Bit0-Modem in direction-A<br/> Bit1-Modem in direction-B</p> |
| <p>BLOCK2</p>  |

If the bit is ‘1’ Modem will be reset.

**Acknowledgement for MODEM RESET:**

|  |
|--|
| <p><b>BLOCK 0</b><br/> TI – CCH<br/> RECORD LENGTH = 07H</p> |
| <p><b>BLOCK 1 (1Byte)</b><br/> Byte1: Success 00</p>         |
| <p><b>BLOCK2</b></p>   |

**BUFFER FULL:**

|  |
|--|
| <p><b>BLOCK 0</b><br/> TI – 8FH<br/> RECORD LENGTH = 07H</p> |
| <p><b>BLOCK 1</b><br/> No Data</p>                           |
| <p><b>BLOCK2</b></p>   |

This command will be sent between data loggers, to intimate other data logger that its buffer is full and it cannot take any more event data at present.

**SET TRAN POINTER:**

|   |
|---|
| <p><b>BLOCK 0</b><br/> TI – 90H<br/> RECORD LENGTH = 10H</p>  |
| <p><b>BLOCK 1</b><br/> (9 bytes)<br/> Byte1: Port No (1...2)<br/> Bytes2 &amp;3: SEQ No<br/> Byte4 to 7: Packed Time<br/> Byte8: DL ID<br/> Byte9: Search status.</p> |
| <p><b>BLOCK2</b></p>  |

In bi directional ring communication, when there is a break in one direction, transmission of event packets in that direction gets stop. But in other direction the event packets continue to reach CMU. Once the broken communication link is restored, all pending event packets start flooding continuously towards the CMU. This increases network traffic. Also these packets have been already reached the CMU in other redundant communication path. In order to stop the flow of packets, the pointer in the data logger can be adjusted to the requested event packet. Thus stopping the old events packets flow. This command will move the pointer in the forward direction for the above said condition.

Like wise the pointer need to be moved in backward direction for the need of transmission of old event packets which are available in non-volatile memory. Thus by this command the pointer can be moved back and then old event packets starts transmitted.

Port No:            01H- Network Port in Direction-A  
                       02H- Network Port in Direction-B

SEQ Number, Packed Time & DL ID are the parameters to match the event packet.

Search status : 00H- Forward search.  
                       01H-Backward search.  
                       02H-Set the Tran pointer to the beginning address of  
                       the event packets Database.

**Acknowledgement for SET TRAN POINTER:**

|  |
|--|
| <p><b>BLOCK 0</b><br/>                 TI – D0H<br/>                 RECORD LENGTH = 11H</p>   |
| <p><b>BLOCK 1</b><br/>                 (8 bytes)<br/>                 Byte1: Status<br/>                 Byte2: Port No (1...2)<br/>                 Bytes3 &amp;4: SEQ No<br/>                 Bytes5 to 8: Packed Time<br/>                 Byte9: DL ID<br/>                 Byte10: Search status.</p> |
| <p><b>BLOCK2</b></p>   |

STATUS:      00-SUCCESS  
                  01-SEARCH FAIL.  
                  02- SEARCH FAIL DUE TO INVALID PARAMETERS.  
                  03- SEARCH FAIL DUE TO RECORDS DATA BASE IS IN PURGING.

All Other parameters are echoed back.

**GET RELAY STATUS(1-8):**

|  |
|--|
| <p><b>BLOCK 0</b><br/>                 TI – 91H<br/>                 RECORD LENGTH = 07H</p> |
| <p><b>BLOCK 1</b><br/>                 { NO DATA BYTE }</p>                                  |
| <p><b>BLOCK2</b></p>   |

**Acknowledgement for GET RELAY STATUS:**

|  |
|--|
| <p><b>BLOCK 0</b><br/>                 TI – D1H<br/>                 RECORD LENGTH = 08H</p>   |
| <p><b>BLOCK 1 (1 Byte)</b><br/>                 Byte: Bits 0-7 represent the status of 1-8 relays respectively. If any bit is 1 then the respective relay is picked up and if any bit is 0 then that particular relay is in dropped condition.</p> |
| <p><b>BLOCK2</b></p>   |

**SET RELAY STATUS (1-8):**

|  |
|--|
| <p><b>BLOCK 0</b><br/> TI – 92H<br/> RECORD LENGTH = 08H</p>   |
| <p><b>BLOCK 1</b><br/> 1. Bits 0-7 represent the status of 1-8 relays respectively. If any bit is 1 then that respective relay should be picked up and if any bit is 0 then that particular relay should be dropped.</p> |
| <p><b>BLOCK2</b></p>   |

**Acknowledgement for SET RELAY STATUS:**

|  |
|--|
| <p><b>BLOCK 0</b><br/> TI – D2H<br/> RECORD LENGTH = 07H</p> |
| <p><b>BLOCK 1 (1 Byte)</b><br/> Byte1: Status</p>            |
| <p><b>BLOCK2</b></p>   |

STATUS:      00-Success,  
                  Non-Zero: Fail.

**GET RELAY STATUS(9-16) :**

|  |
|--|
| <p><b>BLOCK 0</b><br/> TI – 93H<br/> RECORD LENGTH = 07H</p> |
| <p><b>BLOCK 1</b><br/> { NO DATA BYTE }</p>                  |
| <p><b>BLOCK2</b></p>   |

**Acknowledgement for GET RELAY STATUS:**

|  |
|--|
| <p><b>BLOCK 0</b><br/>TI – D3H<br/>RECORD LENGTH = 08H</p>   |
| <p><b>BLOCK 1</b><br/>(1 Byte)<br/>Byte: Bits 0-7 represent the status of 9-16 relays respectively. If any bit is 1 then the respective relay is picked up and if any bit is 0 then that particular relay is in dropped condition.</p> |
| <p><b>BLOCK2</b></p>   |

**SET RELAY STATUS(9-16):**

|  |
|--|
| <p><b>BLOCK 0</b><br/>TI – 94H<br/>RECORD LENGTH = 08H</p>   |
| <p><b>BLOCK 1</b><br/>1. Bits 0-7 represent the status of 9-16 relays respectively. If any bit is 1 then that respective relay should be picked up and if any bit is 0 then that particular relay should be dropped.</p> |
| <p><b>BLOCK2</b></p>   |

**Acknowledgement for SET RELAY STATUS:**

|  |
|--|
| <p><b>BLOCK 0</b><br/>TI – D4H<br/>RECORD LENGTH = 07H</p> |
| <p><b>BLOCK 1</b> (1 Byte)<br/>Byte1: Status</p>           |
| <p><b>BLOCK2</b></p>                                       |

STATUS:      00-Success,  
                Non-Zero: Fail.

**A.6.2 BLOCK1:**

**DATA:**

Block 1 is for data, where length is variable.

**A.6.3 BLOCK2:**

**CHECK SUM:**

                This checksum is 16-bit value, and it is placed in the Block2.  
This is calculated as sum of all the bytes starting from RL MSB to last byte stored in  
BLOCK1.

