

ISO 9001-2015	Document No. IRS:TC 83-20	Version - 1.0	Date Effective - 19.05.2021
Document Title- Auto Dialling System for Emergency Socket			

**GOVERNMENT OF INDIA MINISTRY OF RAILWAYS**



सत्यमेव जयते

**INDIAN RAILWAY  
STANDARD SPECIFICATION**

**For**

**AUTO DIALLING SYSTEM FOR EMERGENCY  
SOCKET**

**SPECIFICATION NO. IRS: TC-83-20  
Version-1.0**

**ISSUED BY**

**TELECOM. DIRECTORATE**

**RESEARCH DESIGNS & STANDARDS ORGANISATION  
LUCKNOW-226011**

Prepared by:-	JD/Tele-II:-	Page 1 of 36
---------------	--------------	--------------

ISO 9001-2015	Document No. IRS:TC 83-20	Version - 1.0	Date Effective - 19.05.2021
Document Title- Auto Dialling System for Emergency Socket			

	PREPARED BY	CHECKED BY	APPROVED BY
SIGNATURES			
DATE			
DESIGNATION	JE/Tele	JD/Tele-II	ED/Tele-I

ISO 9001-2015	Document No. IRS:TC 83-20	Version - 1.0	Date Effective - 19.05.2021
Document Title- Auto Dialling System for Emergency Socket			

## 2.0 Document Data Sheet

<b>Document Data Sheet</b>	
Specification No:	IRS:TC- 83-20 Version 1.0
Document Title Name :	Auto Dialling System for Emergency Socket
Author by : Designation :	Sangeeta Pandey Joint Director/Telcom-II
Approved by: Designation :	D.k.Singh ED/Telecom-I
Abstract:	This document specifies technical specification of Auto Dialling System for Emergency Socket

## 3.0 Document Control Sheet

<b>DOCUMENT CONTROL SHEET</b>			
Name	Organization	Function	Level
JE/Tele	RDSO	Member	Prepare
Sangeeta Pandey Joint Director/Telecom-II	RDSO	Member, Issuing Authority	Prepare Review, Issue
D. K. Singh Executive Director/Telecom	RDSO	-	Approve

Prepared by:-	JD/Tele-II:-	Page 3 of 36
---------------	--------------	--------------

ISO 9001-2015	Document No. IRS:TC 83-20	Version - 1.0	Date Effective - 19.05.2021
Document Title- Auto Dialling System for Emergency Socket			

## **TABLE OF CONTENT**

<b>Sr. No.</b>	<b>Name of the Item</b>	<b>Page No</b>
<b>1.0</b>	Forward	5
<b>2.0</b>	Scope	6
<b>3.0</b>	Terminology	6
<b>4.0</b>	Part-1 wayside telephone General and General & operating Requirements	6
<b>5.0</b>	Construction and Materials	8
<b>6.0</b>	Electrical Characteristics	11
<b>7.0</b>	Part-II General Requirements	13
<b>8.0</b>	Operating Requirements	14
<b>9.0</b>	Construction and Materials	15
<b>10.0</b>	Electrical Characteristics	16
<b>10.3</b>	Performance Test	17
<b>11.0</b>	Inspection	17
<b>12.0</b>	Visual Inspection	18
<b>13.0</b>	Type Test	18
<b>14.0</b>	Acceptance Test	19
<b>15.0</b>	Routine Test	19
<b>16.0</b>	Sampling	19
<b>17.0</b>	Rejection	20
<b>18.0</b>	Climatic and Environmental Requirements	20
<b>19.0</b>	Marking	22
<b>20.0</b>	Packing	22

ISO 9001-2015	Document No. IRS:TC 83-20	Version - 1.0	Date Effective - 19.05.2021
Document Title- Auto Dialling System for Emergency Socket			

**SPECIFICATION  
FOR  
AUTO DIALLING SYSTEM FOR EMERGENCY SOCKET**

**SPECIFICATION NO. IRS: TC - 83-20**

**Revision History**

Version	Chapter/Annexure	Revision	Effective Month/Year
IRS:TC-83/2007	Annexure-1 & Annexure-A	First Issue	01.04.2007
IRS:TC-83/2007	Annexure-1 & Annexure-A	Ammendment-1	28.08.2007
IRS:TC-83/2007	Annexure-1 & Annexure-A	Ammendment-2	16/20.12.2016

ISO 9001-2015	Document No. IRS:TC 83-20	Version - 1.0	Date Effective - 19.05.2021
Document Title- Auto Dialling System for Emergency Socket			

## **1.0 FORWARD**

1.1 This specification is issued under the fixed serial No. IRS: TC 83-20. The final No indicates year of original adoption as standard or in event of revision, the year of last revision.

### **ADOPTED-2020, Ver 1.0**

1.2 This specification requires reference to the following Indian Railway Standard (IRS), Indian Telegraphs Department (ITD), Indian Standards (IS) and American Society for Testing and Materials (ASTM) specifications :-

IRS:TC- S 23	Electrical Signalling & Interlocking Equipment
IRS:TC- 5608	Low Frequency Wires & Cable With PVC Insulation and Sheath
IRS:TC- 42:87	Six Pin Emergency Plug & Socket
IRS:TC- 6297	Transformer and Inductors (Power Equipment, Audio Pulse Switching for Electronic Equipment
IRS:TC- 4800 (Pt.)	Enameled round winding wire
IRS:TC- 9000	Basic environmental testing procedures for electronic and electrical

1.3 Wherever, in this specification any of the above mentioned specification are referred to by number only, the latest issue of that specification is implied. Wherever the year of issue is mentioned, the particular issue referred to is meant.

1.4 This specification is intended chiefly to cover the general & operating requirements, constructional features, electrical characteristics and performance requirements of Auto Dialling System for Emergency Socket and does not include the necessary provisions of a contract.

## **2.0 SCOPE:**

2.1 This specification covers the requirements and provision of tests and inspection of Auto Dialling System for Emergency Socket. The system will include one Way side telephone and one Base Station Unit.

2.2 The Wayside Telephone shall work from existing Emergency Sockets provided alongside the Railway Track for talking to control office on Underground RE/Quad Cable Communication Network and Base Station Unit shall be fitted in the Test Room and shall work as part of the overall system.

Prepared by:-	JD/Tele-II:-	Page 6 of 36
---------------	--------------	--------------

ISO 9001-2015	Document No. IRS:TC 83-20	Version - 1.0	Date Effective - 19.05.2021
Document Title- Auto Dialling System for Emergency Socket			

- 2.3 The system shall be capable of connecting Railway Exchange or DOT Exchange by pressing the designated button from the Wayside telephone through Test Room Equipment.
- 2.4 Wayside Telephone will work similar to Auto Telephone and shall become a of Railway Telephone Exchange by pressing (\*) Star and shall become a subscriber of DOT telephone exchange by pressing (#) hash . Connectivity shall be achieved automatically through Base Station Unit provided in the Test Room.

### **3.0 TERMINOLOGY**

- 3.1 For the purpose of this specification, the terminology given in IRS: S-23 shall apply.
- 3.2 The term referred to in this specification but not covered in IRS: S-23 are defined below.
- 3.3 Lot: - A lot of auto dialing system is constituted by the same type manufactured in the same factory during same period using same process and materials.

## **PART I – WAYSIDE TELEPHONE**

### **4.0 GENERAL AND OPERATING REQUIREMENTS**

- 4.1 Auto Dialing Telephone shall be assembled in Siemens type ABS plastic body.
- 4.2 The telephone shall be capable of working on 4-Wire Omni Bus circuit on loaded or unloaded Underground Quad cable system of Indian Railways.
- 4.3 The telephone shall be provided with Reverse polarity protection.
- 4.4 The telephone shall be protected from Surge and Transients by “MOVR” based surge protection system.
- 4.5 The receiver of the telephone instrument shall be protected from acoustic shocks by providing two rectifiers in parallel and with opposite polarity across the receiver.
- 4.6 Workmanship should conform to good engineering practice so as to ensure that the instrument is free from defects, rust, cracks and other defects that could impair the operation or serviceability while in use or under storage. The treatment and finishes shall be such that under operating conditions, no deterioration occurs to any parts of the equipment.

ISO 9001-2015	Document No. IRS:TC 83-20	Version - 1.0	Date Effective - 19.05.2021
Document Title- Auto Dialling System for Emergency Socket			

4.7 All the components, switches, connectors etc. shall be of good quality & industrial grade and its manufacturer shall have valid ISO:9000 certificate for manufacturing of these items. All the numbers of components should be clearly indicated. The LED indicators wherever used shall be of superior quality wide angle with metallic holders. The component type and numbers shall not be defaced. Switches & Connectors shall preferably be CACT/LCSO/CDOT/SISI (Small industries service institution) approved (if available).

4.8 The layout of components and wiring shall be such that all parts are easily accessible for inspection, repairs and replacement.

4.9 The current consumption at 12V DC supply shall not be more than :-

- (i) 20mA in idle condition
- (ii) 100mA during ringing period
- (iii) 50mA during conversation

4.10 The telephone shall be capable of working on 12V DC  $\pm 20\%$ .

**4.11 The power supply arrangement:**

A 12V/ 7 AH sealed maintenance free battery shall be provided for working of way side telephone. Arrangement shall also be made for charging the battery with power ON/OFF indication and battery charging in progress as well as battery fully charged. indication.

4.12 In way side telephone two LEDs shall be provided as an indication of DoT or Railway Exchange connection. One of these LED should glow when concerned key (\*/#) is pressed and remain glowing until the line is disconnected.

4.13 Low battery indication shall be provided in the telephone so that whenever battery voltage drops to 10.8 V, a red LED indication should glow.

4.14 Battery charging circuit shall be in the modular form and it shall be capable to charge the battery @ C/10.

4.15 A ON/OFF switch shall be provided in the telephone power supply circuit.

4.16 A plug shall be mounted on the backside of the box to connect with the AC power.

4.17 Battery shall be firmly clamped in to the box so that it should not topple down during the transportation.



ISO 9001-2015	Document No. IRS:TC 83-20	Version - 1.0	Date Effective - 19.05.2021
Document Title- Auto Dialling System for Emergency Socket			

## 5.0 **CONSTRUCTION AND MATERIALS**

5.1 The way side telephone instrument shall consist of mainly the following parts.

- (i) Body of the Telephone
- (ii) Transmitter and Receiver
- (iii) Handset
- (iv) Cordage
- (v) Cradle Switch
- (vi) Six Pin Emergency Plug
- (vii) Transformers/Induction Coil
- (viii) Push Button Dialer
- (ix) Internal wiring and Printed Circuit Board

### 5.2 **Body of the Telephone**

5.2.1 The Body of the telephone instrument shall be made of ABS (Acrylonitrile Butadiene Styrene) plastic material. Properties of ABS material used shall be as per Appendix A, in case the firm moulds the body at their premises. Alternatively if the body has been procured from outside, it shall be from TEC approved sources having valid and current type approval certificate, the proof of which is required to be submitted in that case test of ABS material shall not be carried out. The color of ABS material used for making the body of the telephone shall be light and in no case it should be black. The manufacturer should provide a thick waterproof bag to protect it from rain water and dust inside it and also for portability”.

### 5.3 **Transmitter and Receiver**

5.3.1 Electro Dynamic Transducer of  $150 \pm 20\%$  ohm impedance shall be used to perform functions of transmitter and receiver.

The manufacturer of transmitter & receiver shall have valid ISO 9000 certificate for manufacturing if these items.

Both transmitters and receiver shall be preferably procured from CACT/LCSO/CDOT/SISI ( Small industries service institution ) approved sources (if available).

The transducers shall be fixed in the transmitter and receiver locations of the handset. Proper locking arrangements shall be ensured. The transducers shall be properly protected against ingress of moisture, dust and insects. The frequency response over the range 300 to 3400 Hz shall be uniform . Howling shall not exist when two Telephones Instruments are connected in parallel in OFF-HOOK positions and when one of the handset is placed with the Transmitter/Receiver in flush with a flat surface. It includes glass surface also.

ISO 9001-2015	Document No. IRS:TC 83-20	Version - 1.0	Date Effective - 19.05.2021
Document Title- Auto Dialling System for Emergency Socket			

#### **5.4 Handset**

5.4.1 The handset shall be of Siemens type made of ABS co polymer confirming to the requirement of Appendix A.

#### **5.5 Cordage**

5.5.1 The coiled cord between Handset and PCB of the Telephone shall be made of tinsel wire. This cord shall be of min.4 core and not less than 2 meters in the length to meet the requirements of this specification.

The Manufacturer of cordage shall have valid ISO 9000 certificate for manufacturing of this item. This cordage shall be preferably procured from CACT/LCSO/CDOT/SISI ( Small industries service institution) if available.

5.5.2 The cord between Six pin plug and telephone instrument shall be straight and mad of multi strand to meet the requirements of this specification.

The Manufacturer of cordage shall have valid ISO 9000 certificate for manufacturing of this item.

This cordage shall be preferably procured from CACT/LCSO/CDOT/SISI (Small industries service institution) if available.

#### **5.6 Cradle Switch:**

5.6.1 Cradle switch shall be of miniature type which shall be operative with minimum one plunger. The plunger shall be pushed and released by the Handset.

#### **5.7 Six Pin Emergency Plug**

5.7.1 Six Pin Emergency Plug shall be as per IRS: TC 42-20.

#### **5.8 Speech Circuit**

5.8.1 The speech circuit shall consist of following parts:-

- i) Trans and Receive amplifier circuits.
- ii) 2 Sets of transformers for isolation and matching.

##### **5.8.1.1 Trans and Receive Amplifiers**

Two amplifiers shall be provided one for Trans and one for Receive. The amplifiers shall be designed with new technology to give the flat frequency response in the range of Voice Frequency with very low distortion. The output level of Tx and Rx amplifiers shall be adjustable by preset provided on PCB.

Prepared by:-	JD/Tele-II:-	Page 10 of 36
---------------	--------------	---------------

ISO 9001-2015	Document No. IRS:TC 83-20	Version - 1.0	Date Effective - 19.05.2021
Document Title- Auto Dialling System for Emergency Socket			

### **5.9 Transformers/Induction Coil:**

- 5.9.1 Two sets of transformers shall be provided to match the transmitter and receiver impedances with the line.
- 5.9.2 The transformer core shall be Cold Rolled Grain Oriented (CRGO) silicon steel of suitable grade or of ferrite to meet the electrical characteristics and other parameters of this specification.
- 5.9.3 Each transformer shall be suitably marked Tx and Rx to identify the trans and receive transformers respectively.
- 5.9.4 Synthetic enameled winding wire complying to IS 4800 Pt I shall be used. Transformer shall be vacuum impregnated.
- 5.9.5 The complete winding shall be protected by proper insulation to avoid ingress of moisture .

### **5.10 Decoder circuit**

- 5.10.1 Standard decoder circuit shall be used .

### **5.11 Ringer circuit**

- 5.11.1 On receipt of the designated number it shall be decoded and a peizo electric buzzer shall be activated even if hand set is off hook.
- 5.11.2 Along with actuation of buzzer respective LED indication (DoT or Railway)should continue to lit until the handset is lifted OFF the cradle.
- 5.11.3 The output level of Buzzer shall be adjustable internally by means of fixed pad.
- 5.11.4 Buzzer sound level shall be 85dBm SPL from 30 cm in all directions around the telephone.

### **5.12 Ring Back Tone Circuit**

- 5.12.1 When the buzzer in the telephone is activated, a ring tone shall be automatically transmitted to the calling Telephone in acknowledgment of the receipt of ring. The level of the ring back tone when measured at receive terminal of Base Unit shall not be less than -10dBm.

ISO 9001-2015	Document No. IRS:TC 83-20	Version - 1.0	Date Effective - 19.05.2021
Document Title- Auto Dialling System for Emergency Socket			

### **5.13 Push Button Dialer Circuit**

5.13.1 This circuit consist of a key pad of 4x3 matrix and shall be capable of generating standard DTMF tones.

### **5.14 Internal Wiring and Printed Circuit Board**

5.14.1 The wiring shall be by means of coloured wires, multi-strand; PVC insulated and shall be capable of carrying the maximum required current of the telephone instrument.

5.14.2 The wiring to components shall be provided with sufficient slack to permit the components to be swung clear of the assembly without any disconnection.

5.14.3 Glass epoxy PCB having minimum 1.6mm thickness shall only be used. The PCB shall be coated with epoxy base anti fungal varnish to provide protection against dust, humidity, fungal infection and mechanical abuses. The copper cladding thickness shall not be less than 35 microns and shall be suitably tinned.

5.14.4 The internal wiring of components of telephone instrument shall be as per Annexure-I.

## **6.0 ELECTRICAL CHARACTERISTICS**

### **6.1 Applied High Voltage Test and Insulation Resistance Test**

6.1.1 The telephone instrument shall withstand without any damage to a test voltage of 1KV, 50Hz, AC rms, applied for a period of one minute, between body and all terminals of Emergency Plug tied together.

6.1.2 The insulation resistance measured with 500V DC between body and all terminals of Emergency Plug tied together and shall not be less than 10Mega ohms.

### **6.2 Transmission Test**

6.2.1 Telephone shall be subjected to various transmission tests by connecting in the test set up as indicated in Annexure-II.

Prepared by:-	JD/Tele-II:-	Page 12 of 36
---------------	--------------	---------------

ISO 9001-2015	Document No. IRS:TC 83-20	Version - 1.0	Date Effective - 19.05.2021
Document Title- Auto Dialling System for Emergency Socket			

**6.2.2 Send Efficiency:** Test set up shall be as per Fig.1 of Annexure-II.

T1 & T2	Terminals of Transmitter	
R1 & R2	Terminals of Receiver	
B1 & B2	Battery Terminals	
Tx1 & Tx2	Trans terminals of Six Pin Plug	
Rx1 & Rx2	Receive terminals of Six Pin Plug	LM Level Meter
P	Any key of key pad.	

The transmitter of the telephone shall be removed and the receiver replaced by a non-inductive resistance of 160 ohms. Terminals B1 & B2 are to be connected to a 12V battery with proper polarity. The oscillator level shall be adjusted such that it is -44dBm at 1000 Hz measured across the terminals T1 & T2. The trans terminals of Six Pin Plug shall be terminated by non-inductive resistance of 1120 ohms. The level across 1120 ohms shall be greater than 0 (zero) dBm and total Harmonic distortion shall not be more than 3%.

**6.2.3 Tone Generator Level:** The level of the tone generator shall be adjustable from -4 to -10 dBm across the trans terminals.

**6.2.4 Receive Efficiency:** The test set up is as shown in Fig.2 of Annexure-II.

The line shall be simulated by non-inductive resistance of 560+560 ohms. The level and frequency at Rx terminals of Six Pin Plug shall be adjusted to -20dBm and 1000Hz respectively. The level measured across terminals R1 & R2 shall be greater than -18dBm. The total harmonic distortion shall not be more than 3%.

The frequency response of Cl. 6.2.2 and 6.2.4 shall be  $\pm 3$ dBm in the frequency range 300 to 3400 Hz.

**6.2.5 Insertion Loss:** The test set up is as shown in Fig.3 of Annexure-II.

**(i) (a) ON Hook Condition:**

With the set up as in Figure 3, oscillator level is set to 0 dBm across 1120 ohms without the telephone being connected. The microphone shall be disconnected and terminal T1 & T2 shall be looped together. Then the trans or receive terminals are connected across 1120 ohms resistance as shown in Fig. The drop in the reading of the level meter shall not be greater than 0.5dB.

**(ii) (b) OFF Hook Condition:**

With the same set up as in Fig.3, the oscillator level is set to 0 dB across 1120 ohms without the telephone being connected. Then trans or receive terminals are connected to 1120 ohms. The drop in the reading of the level meter shall not be greater than 1.0dB.

ISO 9001-2015	Document No. IRS:TC 83-20	Version - 1.0	Date Effective - 19.05.2021
Document Title- Auto Dialling System for Emergency Socket			

**6.3 Decoder Test**

- 6.3.1 The telephone shall respond faithfully for the signaling from DTMF Control Office equipment or similar type telephone with a minimum level of -25dBm and maximum level up to 0 dBm even when the line S/N Ratio is 15 dBm.
- 6.3.2 Decoder shall not respond for any frequency or combination of frequencies other than DTMF frequencies.

**6.4 Performance Test**

- 6.4.1 The connection between two telephone instruments shall be made as shown in Annexure-III. The conversion and Signaling shall be checked for:-
  - (i) Clarity of speech and audibility
  - (ii) Signaling performance

**PART-II BASE STATION UNIT**

**7.0 GENERAL REQUIREMENTS**

- 7.1 It shall consist of 2 Way Voice Communication circuit and code reception.
- 7.2 This shall be provided in the test room and shall have aesthetic look. This shall be suitable for mounting on 19" rack. The dimensions and layout will be as per Annexure-IV a & IV b\*.
- 7.3 All the components, Switches and connectors shall be of industrial grade and its manufacturer shall have valid ISO 9000 certificate for manufacturing of these items.  
Switches & Connectors shall preferably be CACT/LCSO/CDOT/SISI (Small industries service institution) approved (if available).
- 7.4 All the indications at the unit shall be of continuous type and shall be by colored 'LED' or 7-segment Red 'LED' displays.
- 7.5 All the switches, connectors and indications shall be legibly marked/embossed in bold alphanumeric characters in English.
- 7.6 Base unit housing will be made up of ' Aluminum alloy sheet conforming to IS:737 NS- 3, half hard, 210.2 mm and finishing powder coated Siemens light grey'.

ISO 9001-2015	Document No. IRS:TC 83-20	Version - 1.0	Date Effective - 19.05.2021
Document Title- Auto Dialling System for Emergency Socket			

## **8.0 OPERATING REQUIREMENTS**

- 8.1 The system shall permit working of Voice Communication and signaling on an Omnibus Circuit from Emergency Sockets on 4-Wire basis.
- 8.2 It shall be possible to connect Railway Telephone Exchange or DOT Telephone Exchange on reception of valid code from the field, only one at a time.
- 8.3 \*The base unit shall be compatible to work with PET Quad (characteristic impedance 470 ohms) are paper quad (characteristic impedance 1120 ohms) and also on PCM channel (OFC) having characteristic impedance of 600 ohms.
- 8.4 All the incoming lines terminated on the base unit shall have Surge protection device. The device is to be installed before the base station unit. The arrester should be rail mounted to protect two signal conductor pairs of the telecommunication interface i.e., DOT exchange & Railway Exchange respectively. As a connection to the telecommunication network, the surge protection has screw terminal on the 'IN' side and on the 'OUT' side, two RJ 11 sockets that are in parallel, in addition to the screw terminals. The device should be a combination of GD tube & Suppressor diode & should be able to discharge a total surge current of 10 KA of 8/20  $\mu$ s. The device should be rated for 185 V DC. The residual voltage should be  $\leq$  50 V. The device should be as per IEC61643-21. (Connection scheme attached in Annexure: VIII)
- 8.5 The connection of 4W emergency control line circuit coming from OFC room or through underground cable shall be terminated on the male plug and the socket should be fitted on the body of the equipment so that in coming line can be connected properly having locking arrangement.
- 8.6 Audio Visual indication shall be provided on the Base Station Unit to indicate the connected Exchange. The LED shall continue to glow until line is disconnected, but buzzer should sound only for approximately 2 seconds. If concerned relay in the base unit does not operate LED indication would not come, only buzzer will sound for 2 seconds as a indication that the way station telephone tried to establish a connection with the exchange.
- 8.7 A loudspeaker and associated amplifier shall be provided for Auto monitoring of the Ring. Ring Back Tone and conversation between the Wayside Telephone and Exchange subscriber.
- 8.8 12 digits, seven segments LED display shall be provided to indicate the called telephone number.
- 8.9 The selected Exchange shall be disconnected when the same digit code is again pressed from Wayside Telephone. It shall not be possible to disconnect the selected Exchange by any other code.

ISO 9001-2015	Document No. IRS:TC 83-20	Version - 1.0	Date Effective - 19.05.2021
Document Title- Auto Dialling System for Emergency Socket			

8.10 It shall not be possible to select both Exchanges at the same time.

8.11 It shall be possible to call Wayside Telephone by dialing a designated number from any exchange and ringing shall be produced to the Wayside Telephone. It shall be possible to connect the Wayside Telephone to incoming call by pressing \*/ #, respective LED indicating (DOT or Rly) should continue to lit until the \*/# key of telephone is again pressed to disconnect the line.

## **9.0 CONSTRUCTION AND MATERIALS**

**9.1** The base unit shall consist of the following parts :-

- (i) 4 Wire to 2 Wire conversion circuit
- (ii) DTMF Decoder and Relays circuit
- (iii) Speech Circuit
- (iv) Loud Speaker Amplifier
- (v) LED Indications and 7 segment display circuit

### **9.2 4 Wire to 2 Wire Conversion Circuit**

9.2.1 This circuit shall have a hybrid to convert 4 Wire circuit which is coming from Emergency circuit to base unit into 2 Wire circuit.

9.2.2 It shall have a trans amplifier and a Receiver amplifier and on 2-Wire side, shall have speech band pass filter.

### **9.3 DTMF Decoder Circuit**

9.3.1 Decoder circuit shall faithfully decode any DTMF tone and drive the 7 Segment display.

9.3.2 First digit shall lit one LED among any two LED provided to indicate Rly. or DOT and also operate the desired relay to connect any one of the required exchange line. Rest of the dialed digits shall be displayed by 7 segment LED display provided for numeric display.

### **9.4 Speech Circuit**

9.4.1 The speech circuit ( Tx., Rx) shall work with the 4-Wire/2-Wire conversion circuit.

9.4.2 Provision to connect the Handset shall also be provided.



ISO 9001-2015	Document No. IRS:TC 83-20	Version - 1.0	Date Effective - 19.05.2021
Document Title- Auto Dialling System for Emergency Socket			

## **9.5 Loud Speaker Amplifier Circuit.**

9.5.1 A loud speaker amplifier circuit shall be provided with volume control to monitor the incoming and outgoing speech.

## **9.6 LED Indication and 7-Segment Display:**

9.6.1 2 LEDs shall be provided on the front panel of base unit. RED LED shall indicate 'RLY' and "GREEN" shall indicate "DoT".

9.6.2 7-Segment LED display shall be provided to display the dialed number from the Wayside Telephone in numeric form.

## **9.7 Internal Wiring & Printed Circuit Board.**

9.7.1 The wiring shall be by means of coloured wires, multi-strand, PVC insulated and shall be capable of carrying the maximum required current of the unit.

9.7.2 The wiring to components shall be provided with sufficient slack to permit the components to be swung clear of the assembly without any disconnection.

9.7.3 Glass epoxy PCB having minimum 1.6mm thickness shall only be used. The PCB shall be coated with epoxy base anti-fungal varnish to provide protection against dust, humidity, fungal infection and mechanical abuses. The copper cladding thickness shall not be less than 35 microns and shall be suitably tinned.

9.7.4 The internal wiring of components of the Unit shall be as per Annexure-V.

## **10.0 ELECTRICAL CHARACTERISTICS**

### **10.1 Applied High Voltage Test & Insulation Resistance Test**

10.1.1 The Unit shall withstand without any damage to a test voltage of 1KV, 50Hz, AC rms, applied for a period of one minute, between body and all terminals of the Base Unit tied together.

10.1.2 The insulation resistance measured with 500V DC between body and all terminals of the Base Unit tied together, shall not be less than 10 Mega ohms.

### **10.2 Transmission Test**

10.2.1 The base unit shall be subjected to various transmission tests by connecting the set up as given in Annexure-VI.

Prepared by:-	JD/Tele-II:-	Page 17 of 36
---------------	--------------	---------------

ISO 9001-2015	Document No. IRS:TC 83-20	Version - 1.0	Date Effective - 19.05.2021
Document Title- Auto Dialling System for Emergency Socket			

### 10.2.1.1 Send Level

An audio oscillator shall be connected to Rx terminal of base unit. The level and frequency of the oscillator shall be adjusted at 0dBm at 1000Hz. The level measured across 2 Wire terminals shall not be less than 0dBm with maximum harmonic distortion of 3% when it is terminated by 600 ohms non-inductive resistance.

### 10.2.1.2 Receive Level

Oscillator shall be connected to 2 Wire terminal at the level 0dBm and 1000Hz frequency. The level measured across Rx terminal of base unit shall not be less than 0dBm with maximum harmonic distortion of 3% when it is terminated by 1120 ohm non-inductive resistance.

10.2.1.3 The frequency response of both the above tests shall be within  $\pm 3$ dBm. Tx and Rx Amplifiers shall not over load up to 0 dBm output. The impedances of Tx, Rx and 2-Wire terminal shall be 1120, 1120 and 600 ohm  $\pm 10$  % respectively for proper impedance matching to line.

## 10.3 Performance Test

10.3.1 A 4-Wire DTMF Telephone shall be connected to Tx and Rx terminal of the base unit and a 2-Wire Control Telephone at 2-Wire terminal. Railway Exchange terminal to Railway Exchange line and DOT terminal to DOT Exchange line as indicated in Annexure-VII.

The following operation of the base unit shall be checked :-

- i) Clarity of speech between the telephone
- ii) Loudness of Voice and action of volume control in loud speaker circuit
- iii) Operation of Relay 1 & Relay 2
- iv) Dial tone and Ring back of both exchanges
- v) Conversation between 4-Wire DTMF telephone to both subscriber telephone (Rly and DOT) one by one
- vi) Indication and numeric display

## 11.0 INSPECTION

11.1 The inspection and test shall be carried out to the satisfaction of the purchaser or his nominee.

11.2 The purchaser or his nominee shall have the right to be present during all stages of manufacture and shall be accorded all reasonable/complete facilities to satisfy himself that the Auto Dialling System are being manufactured in accordance with the terms and conditions of the specification. The purchaser or his nominee shall have the right to reject any material that fails to conform to the specification.

Prepared by:-	JD/Tele-II:-	Page 18 of 36
---------------	--------------	---------------

ISO 9001-2015	Document No. IRS:TC 83-20	Version - 1.0	Date Effective - 19.05.2021
Document Title- Auto Dialling System for Emergency Socket			

- 11.3 When the inspection is carried out during the manufacturing process, the manufacturer shall supply the material and samples required for testing free of charge and shall at his own cost prepare and furnish the necessary test pieces and appliances for such testing as may be carried out at his own premises in accordance with the specification. The manufacturer shall bear the cost of carrying out the tests at an approved test laboratory for conducting the tests for which firm is not having in-house test facilities.
- 11.4 Test certificates incorporating the results of the routine test and other manufacturing tests must be furnished in quadruplicate prior to the inspection for the use of purchaser/his nominee.

## **12.0 Visual Inspection**

- 12.1 The instrument shall be visually inspected to ensure that the mouldings are free from rachs (for ABS body) , other imperfections and that all the components are fitted properly.
- 12.2 Instruments shall be checked to satisfy general and operating requirements (Cl.4) construction (Cl.5) of Wayside Telephone and General Requirements (Cl.6). Operating Requirements (Cl.8), Construction (Cl.9) of Base Station Unit and Marking (Cl.16).
- 12.3 The faulty sub-assembly and or samples failing in routine/acceptance test shall be destroyed effectively. The exercise of effective destruction during the manufacture/routine test shall also be shown to the inspecting authority as and when asked for.

## **13.0 TYPE TESTS**

- 13.1 Type tests shall include complete tests in accordance with this specification
- 13.2 Type tests shall comprise of the following :-
- (i) Visual inspection (Cl.12.0)
  - (ii) Electrical tests (Cl.6 &10)
  - (iii) Climatic and Environmental Requirements (Cl. 18.0)
  - (iv) Performance tests (Cl. 6.4 &10.3).

Two samples of each (Way side Telephone and Base Unit) shall be selected at random for type tests from the specially made sample for initial type test or from normal production for Maintenance Type Approval.

- 13.3 The sequence of type tests shall be in accordance with the Appendix-B.

Prepared by:-	JD/Tele-II:-	Page 19 of 36
---------------	--------------	---------------

ISO 9001-2015	Document No. IRS:TC 83-20	Version - 1.0	Date Effective - 19.05.2021
Document Title- Auto Dialling System for Emergency Socket			

#### **14.0 Acceptance Tests**

14.1 Acceptance tests shall comprise of the following tests taken in sequential order as follows:-

- (a) Visual inspection (Cl. 12.0)
- (b) Electrical requirements (Cl.6 &10 ).
- (c) Performance Test (Cl.6.4 &10.3)

#### **15.0 Routine Tests**

15.1 Following routine tests shall be conducted on Auto Dialling Systems

- (a) Visual Inspection (Cl. 12.0)
- (b) Electrical Tests (Cl.6 &10)
- (c) Performance Test (Cl. 6.4 &10.3)

15.2 Any other tests required by the manufacturer to ensure that Auto Dialling System is in conformity with the requirements of this specification.

#### **16.0 SAMPLING**

16.1 Unless otherwise agreed to by the purchaser and the supplier, the double sample plan given below shall be adopted:-

Lot consisting of Auto Dialling System	1 <sup>st</sup> sample size (N1)	2 <sup>nd</sup> sample size (N2)	Combined sample size (N1+N2)	Acceptance Number (C1)	Rejection Number (C2)
1	2	3	4	5	6
Under 25	3	6	9	0	2
25 to 50	7	14	21	0	3
51 to 100	10	20	30	0	3
101 to 200	13	26	39	0	5
201 to 300	20	40	60	1	5
301 to 500	25	50	75	1	6

ISO 9001-2015	Document No. IRS:TC 83-20	Version - 1.0	Date Effective - 19.05.2021
Document Title- Auto Dialling System for Emergency Socket			

16.2 The number of Auto Dialling System (N1) as given in co.2 shall first be selected and subjected to the acceptance test. If in the first sample, the number of defective Auto Dialling System, that is those failing in one or more acceptance tests, is less than/equal to the corresponding number (C1) given in Col.5, the lot shall be considered as conforming to the requirements of the acceptance test. If the number of defective Auto Dialling System in the first sample is greater than or equal to the rejection number given in Col.6, the lot shall be considered as not conforming to the requirement of the acceptance test. If number of defective Auto dialling system in the first sample lies between (C1 ) and (C2) a second sample of size (N2) as given in Col.3 shall be selected and subjected to acceptance test. If in the combined sample, the number of defective Auto Dialling is less than (C2), the lot shall be considered as conforming to the requirements of acceptance test.

16.3 The sample shall be selected at random from at least 10% of the packages. For random selection of packages, all the packages in the lot shall be arranged in a serial order and every 'r' the package shall be selected until the requisite number of packages is obtained.

'r' being the integral part of: 
$$\frac{\text{Total Number of packages in the lot}}{\text{Total number of packages to be selected}}$$

**17.0 REJECTION:**

17.1 Any of the materials which do not comply with the requirements of this specification may be rejected.

**18.0 CLIMATIC AND ENVIRONMENTAL REQUIREMENTS**

18.1 Auto Dialling System shall function satisfactorily under the following climatic and environmental conditions tested as per IS: 9000 series.

18.1.1 Change of Temperature Test (Part XIV – Section 2)

Low Temperature: -10°C±3°C

High Temperature: +55°C±2°C

Rate of change of temperature over a period of not more than 5 minutes should be ±0.2°C/minute

Duration: 3 hours

No. of cycles: 2.

18.1.2 Dry heat test (Part III Section 3) 55±2°C

Duration: 12 hours

ISO 9001-2015	Document No. IRS:TC 83-20	Version - 1.0	Date Effective - 19.05.2021
Document Title- Auto Dialling System for Emergency Socket			

18.1.3 Damp heat (cyclic test) (Part V  
Section 2).

Duration: 12+12 hours  
Ist cycle of two cycles Upper  
temperature: 40°C Variant: 1.

18.1.4 Cold Test (Part II Section 3): -  
10°C±3°C. Duration: 2 hours.

18.1.5 Damp heat cyclic Test: 12+12 hours  
2<sup>nd</sup> cycle of 2 cycles  
Upper temperature 40°C  
Variant 1.

18.1.6 Salt Mist Test (Part I) Procedure 1.  
Duration 48 hours.

**18.1.7 Vibration test:-**

18.1.7.1 The system i.e. both equipments shall be subjected to vibration test as per IS:  
9000 (Part VIII).

- (i) Frequency Range: 10Hz to 55 Hz
- (ii) Vibration amplitude: 0.35 mm
- (iii) Duration of endurance 20 sweeps cycles  
for sweep ( 10Hz -55Hz – 10Hz)
- (iv) No.of axes 3 coordinate axes
- (v) Duration at resonant freq. 30 minutes ±1 minute
- (vi) Value of 'g' 1 g'

18.1.8 Drop Test

18.1.8.1 The equipment shall be allowed to drop freely from the height of 25 mm on to a 13mm thick steel plate, which has been wet-floated on, and bolted down to a fully set block of concrete at least 500 mm thick.

18.1.8.2 The height of drop shall be 25mm measured from that point of the equipment nearest to the surface of the steel plate when suspended prior to dropping.

Prepared by:-	JD/Tele-II:-	Page 22 of 36
---------------	--------------	---------------

ISO 9001-2015	Document No. IRS:TC 83-20	Version - 1.0	Date Effective - 19.05.2021
Document Title- Auto Dialling System for Emergency Socket			

18.1.8.3 The minimum number of drop shall be six.

18.1.9 The electrical test (Cl. 6.0 & 10.0) shall be repeated after the completion of climatic test, vibration test and drop test. The parameters shall be within  $\pm 5\%$  of the initial value. The visual inspection as per (Cl. 12.0) and performance as per (Cl. 6.4 & 10.3) shall also be checked.

**19.0 MARKING:**

19.1 The following shall be legibly and indelibly screen printed on the outer surface of Auto Dialling System (both units).

- (i) Manufacture's name
- (ii) Specification Number
- (iii) Month & Year of Manufacture
- (iv) Serial Number
- (v) Batch No.

**20.0 PACKING**

20.1 Auto Dialling System shall have to undergo arduous Transportation before reaching the destination and will have to be stored and handled in tropical climatic conditions (including monsoon) before they are put to actual use. It is therefore imperative that the packing is decided by taking into consideration, inter-alia, the above two factors so as to avoid damage/deterioration of the system in transit/transshipment/handling and during storage.

21.0 All the provisions contained in RDSO's ISO procedures laid down in Document No. QO-D-8.1-11(titled "Vendor-Changes in approved status") and sub sequent versions/amendments thereof, shall be binding and applicable on the successful vendor/vendors in the contracts floated by Railways to maintain quality of product supplied to Railways.

ISO 9001-2015	Document No.IRS:TC- 83-20	Version:- 1.0	Date Effective:- 19.05.2021
Document Title- Auto Dialling System for Emergency Socket			

**APPENDIX –‘A’**  
**REQUIREMENTS OF ABS (ACRYLONITRILE BUTADYNE STYRENE)**  
**CO-POLYMER MOULDING MATERIAL**

**1–PROPERTIES:**

The material from test sample of finish body shall satisfy the following properties.

S.No.	Property		ATSM Test
1.1	Mechanical properties		
1.1.1	Tensile strength.	380Kgf/cm <sup>2</sup>	D-638
1.1.2	Izod Impact Strength Noticed.	i) at 23°C F:25kg-cm/cm(Min) ii) at 0°C: 20 kg-cm/cm (Min)	D-256 (A)
1.2	<b>Thermal Properties</b>		
1.2.1	Heat Deflection temp.	i) at 18.5kg/cm <sup>2</sup> 99°C (Min) ii) at 4.6kg/cm <sup>2</sup> 100°C (Min)	D-648
1.2.2	Flammability	1.5 inches/minute (Max. 81cms)	D-635
1.3	Hardness	95-110 on R Scale	D-785
1.4	<u>Test on Finished Product made of ABS material</u>		
1.4.1	Specific Gravity	1.04 – 1.07	ASTM D-792
1.4.2	. Vicat Softening Point	100 - 108° C	ASTM D - 1525

Test on Finished Product made of ABS material.

A special sample of the size as required and mentioned in the test method ASTM D- 1525 and ASTM-D-792, should be manufactured from the same raw material as used for moulding the body of Telephone or a part of the Telephone body will be cut to conduct the tests mentioned in Para 1.4.1& 1.4.2 of Appendix ‘A’



APPENDIX 'B'

Sequence of type tests : (Cl. 13.3)

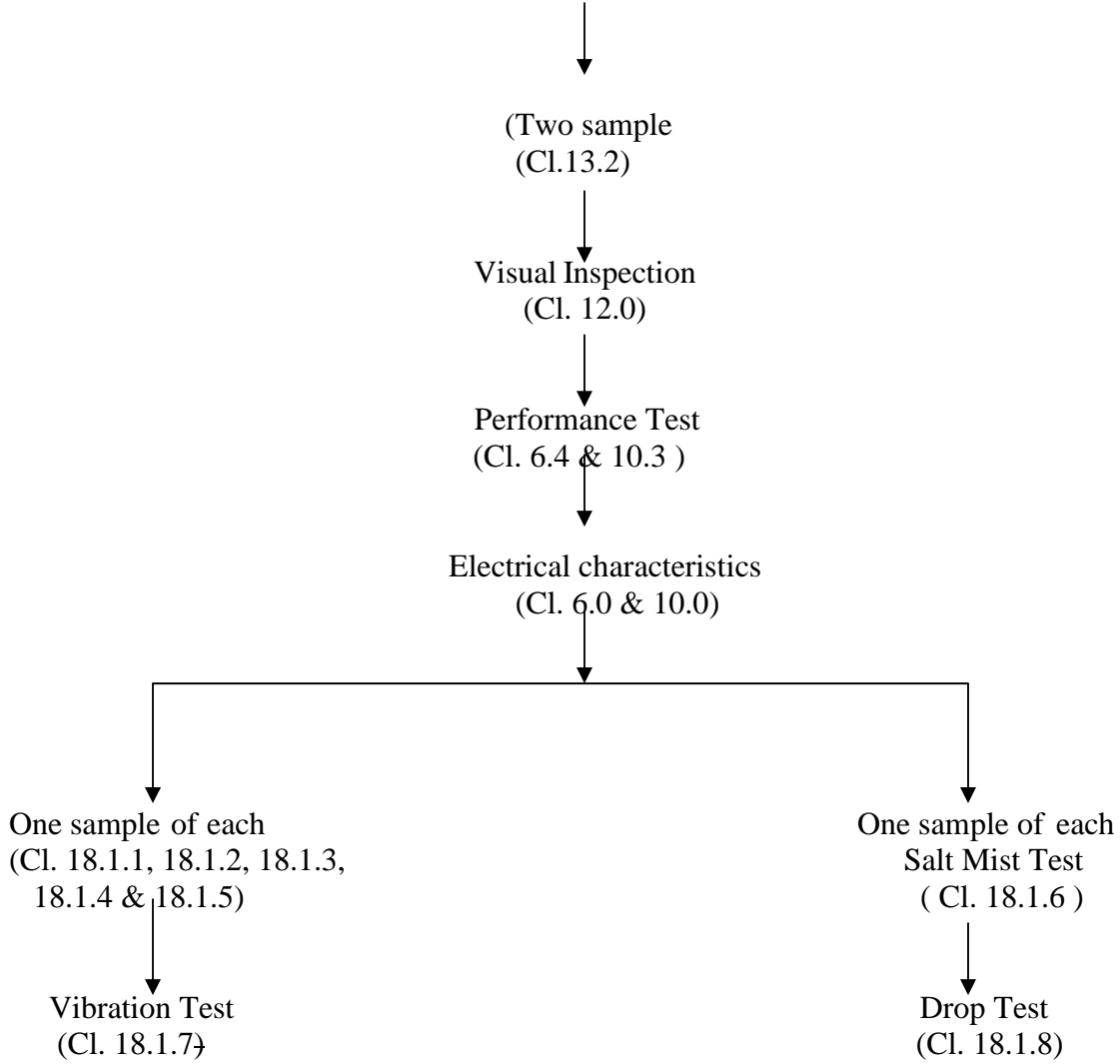

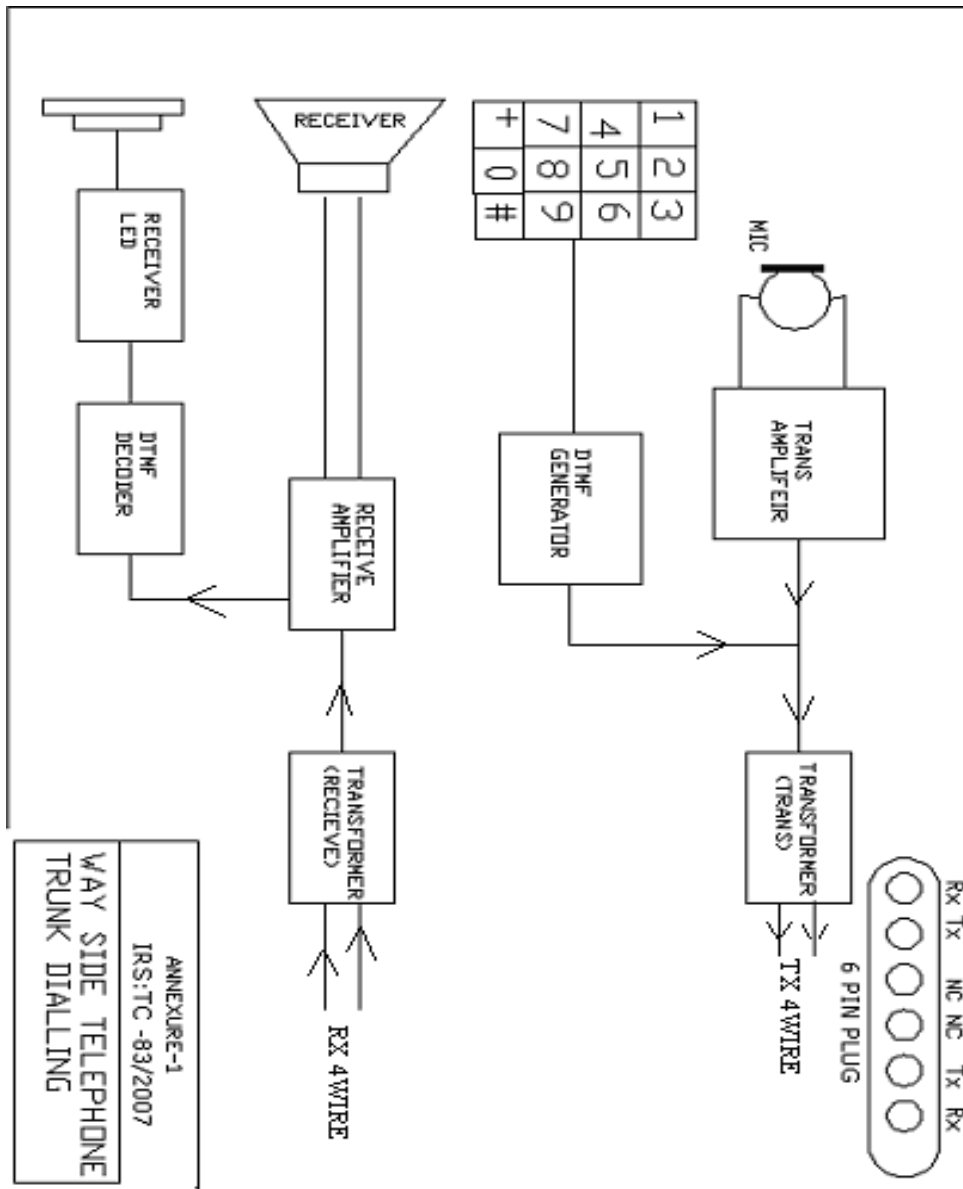

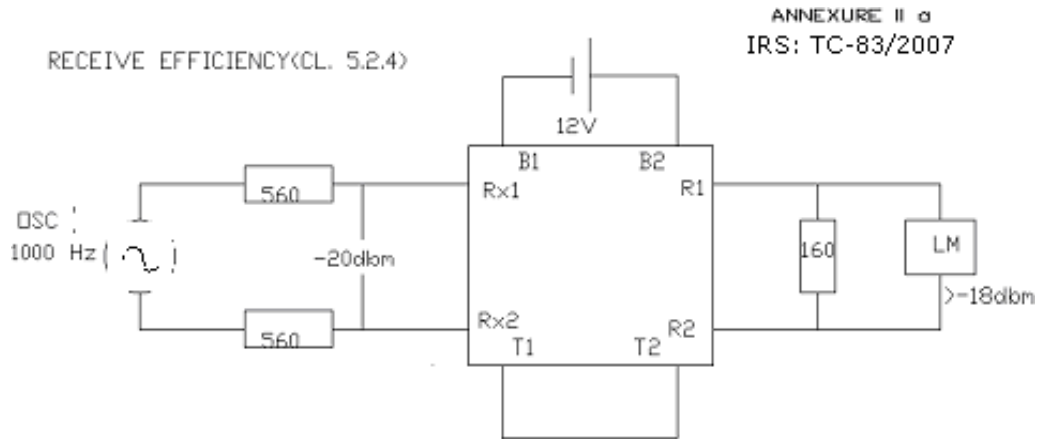

Fig 1 TEST SETUP FOR RECEIVE EFFICIENCY

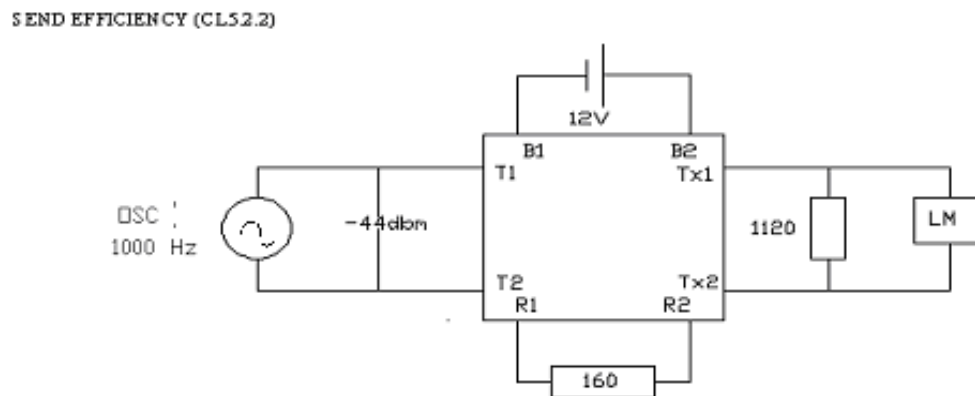
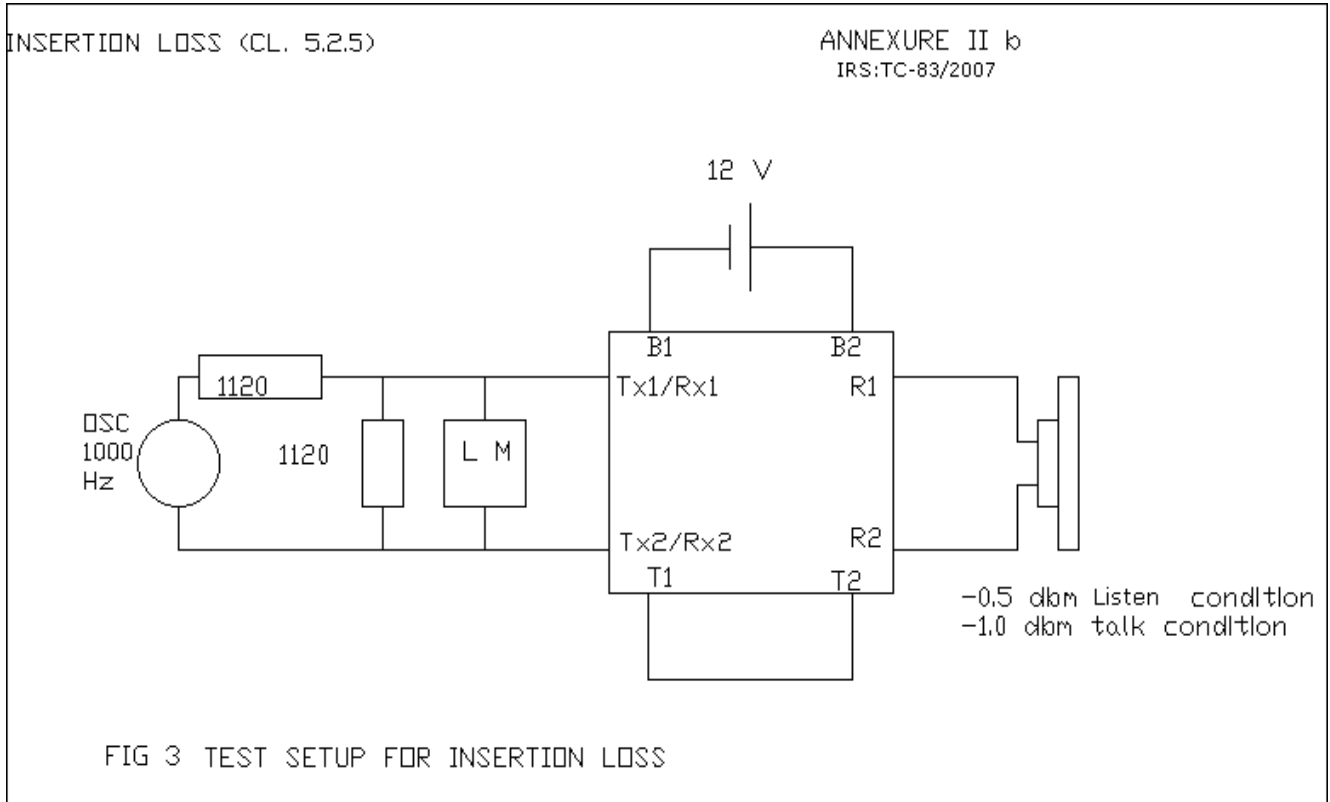

Fig 2 TEST SETUP FOR SEND EFFICIENCY

T1 & T2 : TERMINALS OF TRANSMITTER INSET  
 R1 & R2 : TERMINALS OF RECIEVER  
 L1 & L2 : LINE TERMINALS  
 Tx1 & Tx2 : TRANS TERMINALS OF SIX PIN PLUG  
 Rx1 & Rx2 : RECEIVE TERMINALS OF SIX PIN PLUG  
 B1 & B2 : BATTERY TERMINALS  
 LM : LEVEL METER



ISO 9001-2015	Document No.IRS:TC- 83-20	Version:- 1.0	Date Effective:- 19.05.2021
Document Title- Auto Dialling System for Emergency Socket			

Performance Test (Cl.5.4)

ANNEXURE-III  
IRS:TC-83/2007

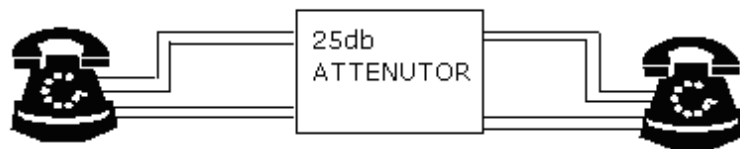

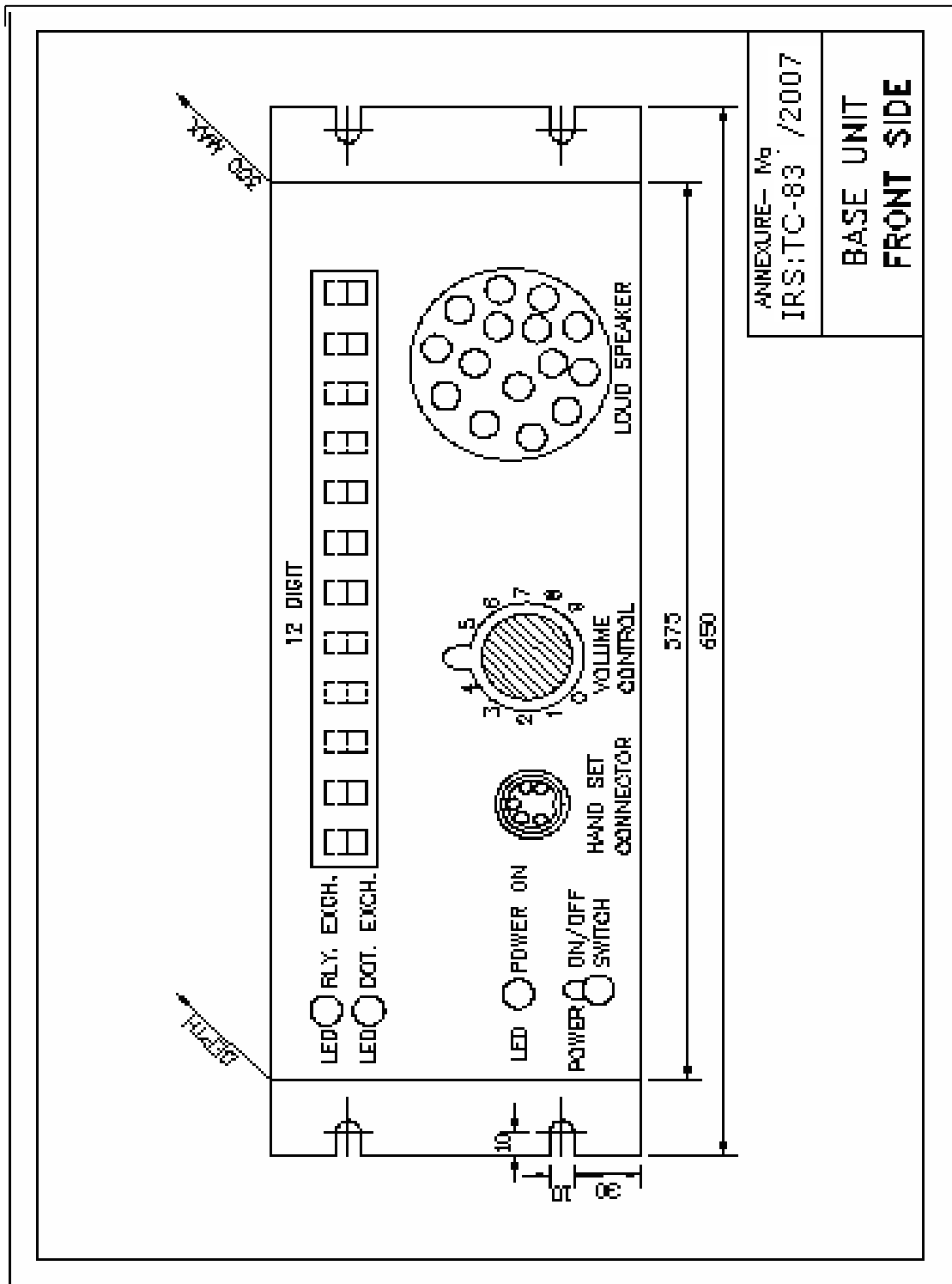

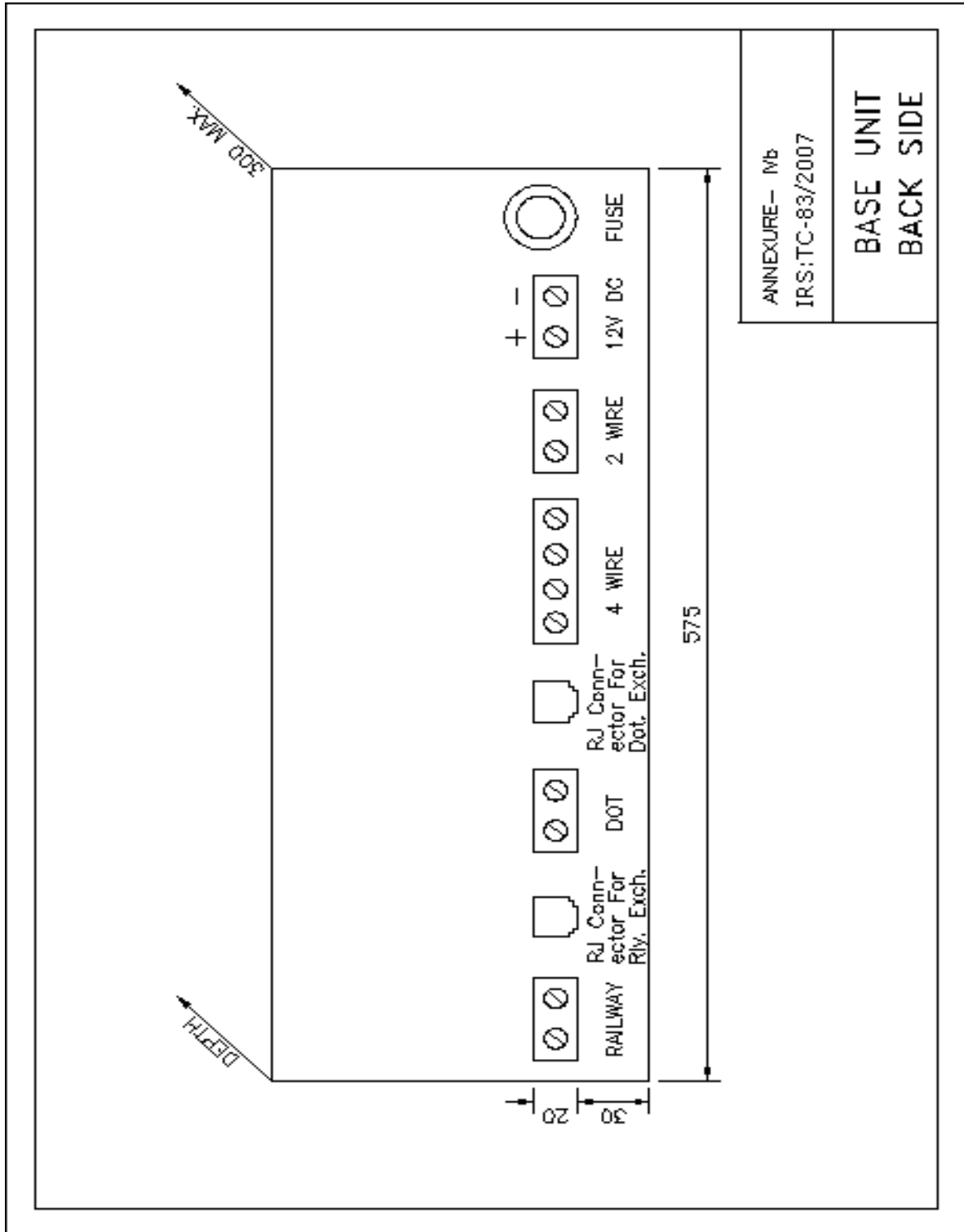

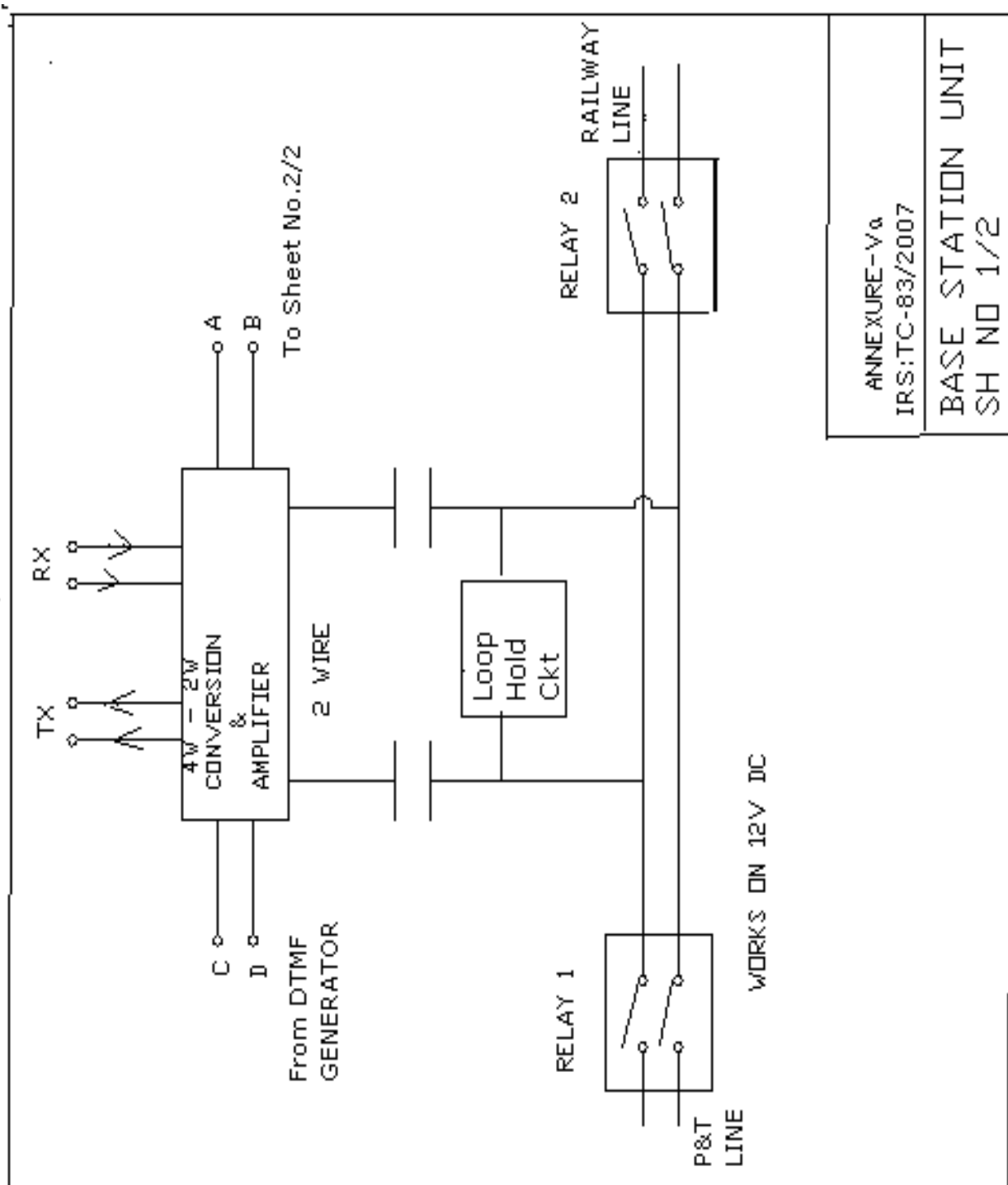

ANNEXURE-Va  
IRS:TC-83/2007

BASE STATION UNIT  
SH NO 1/2



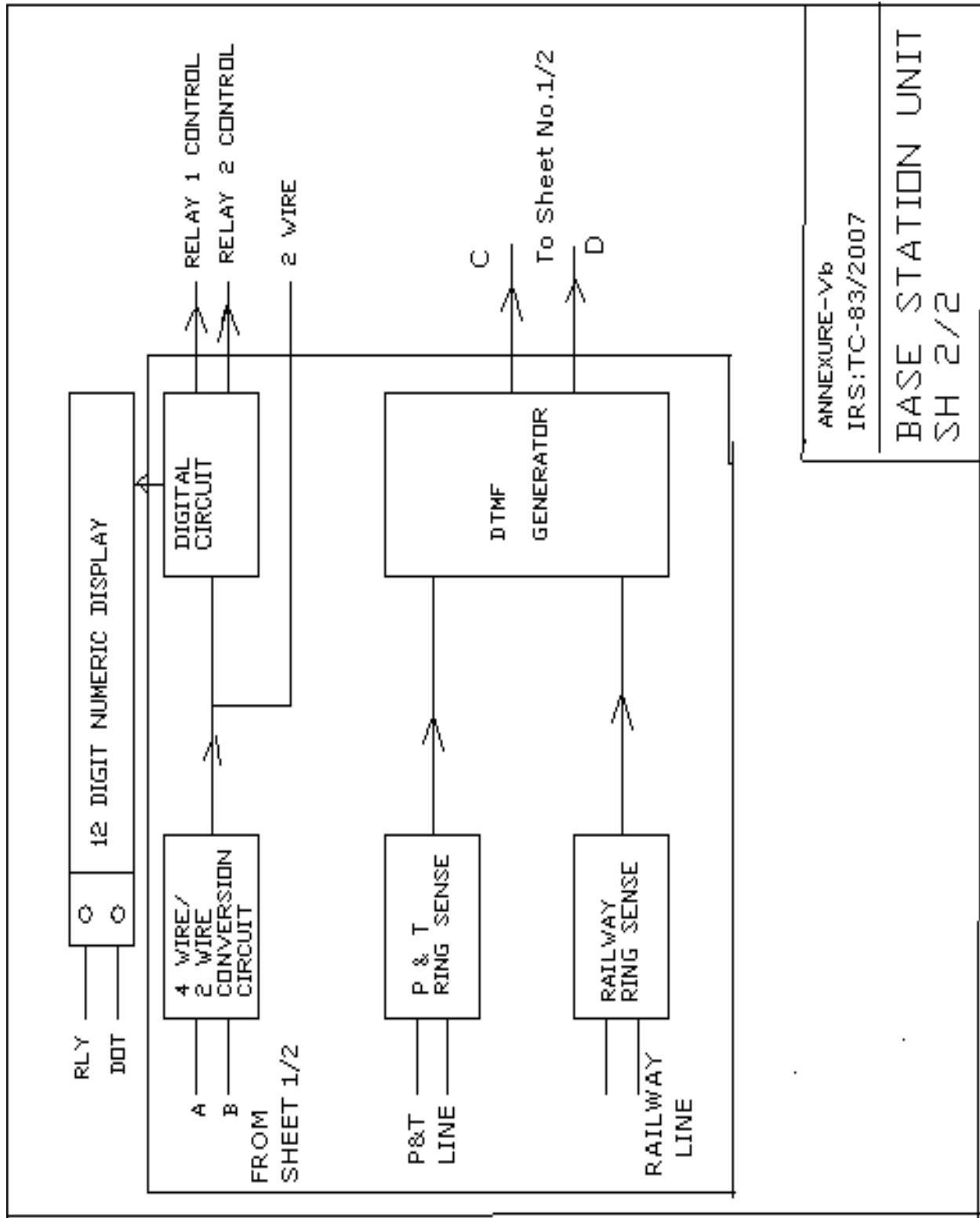

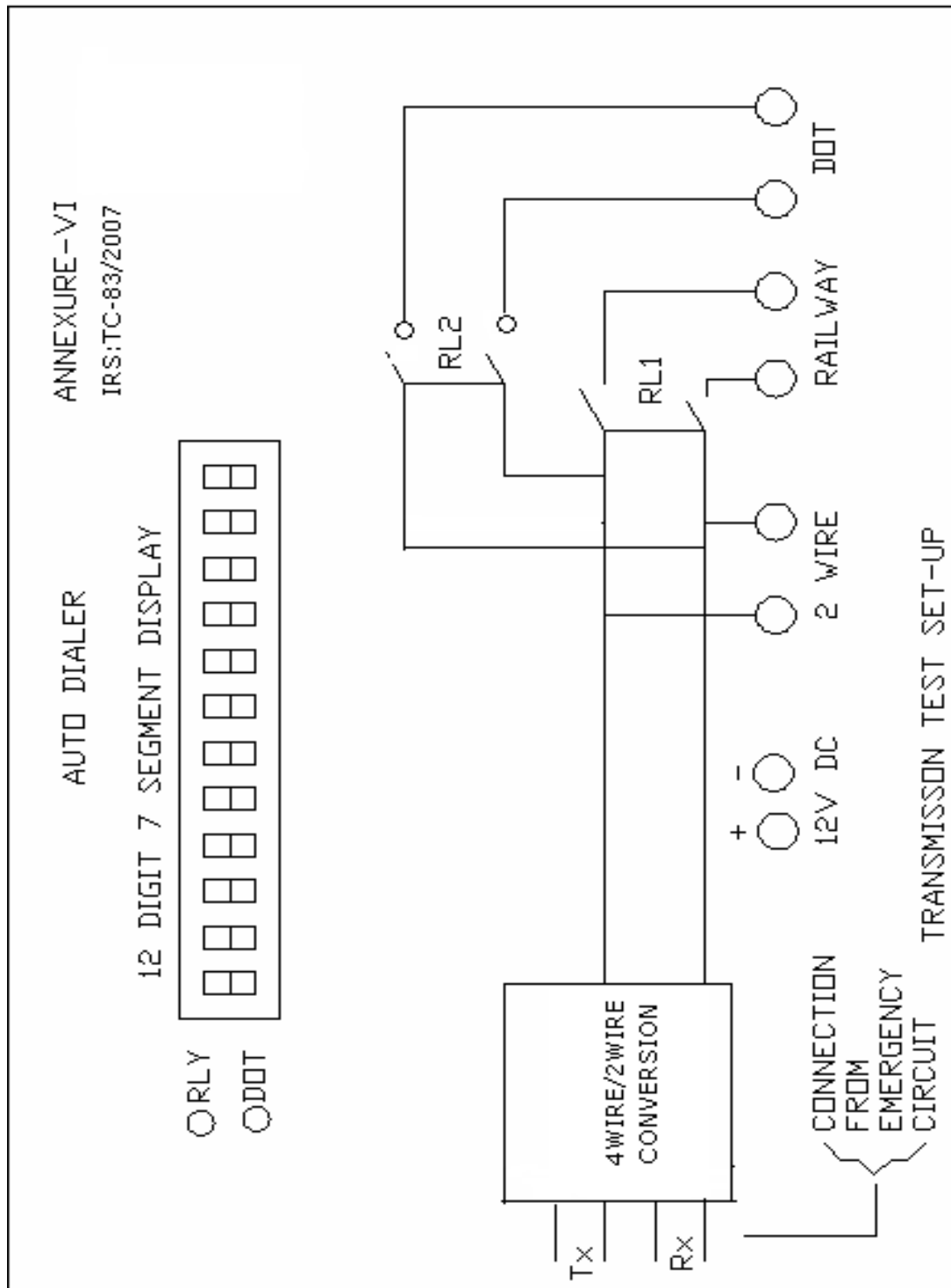

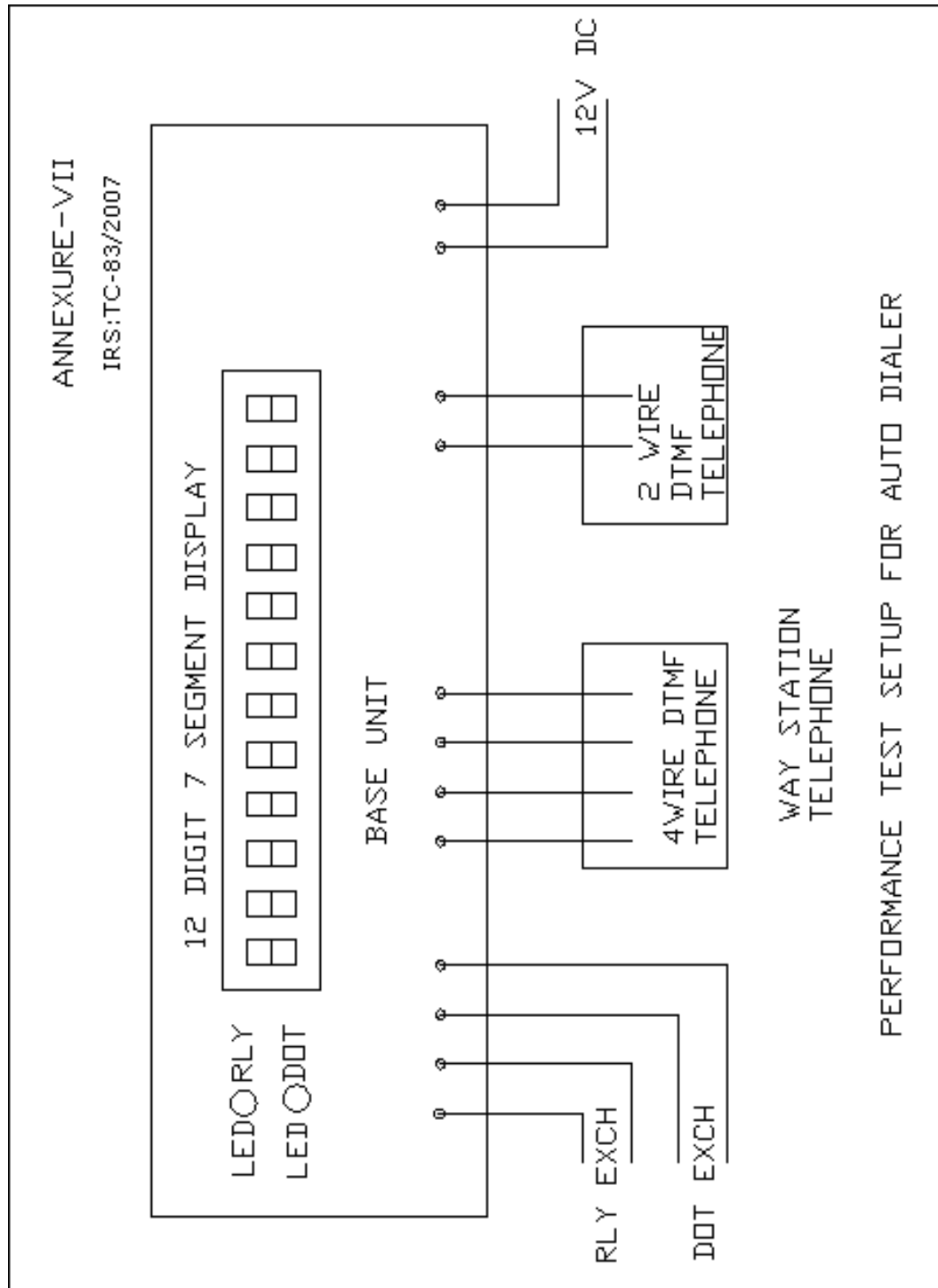

**Annexure VIII**

